

# ORDINANCE 21-11-01

**Introduced: Nov. 1, 2021**

**Approved:**

## **AN ORDINANCE TO AMEND CHAPTER 46 IN THE TOWN OF MIDDLETOWN CODE OF ORDINANCES, THE CONSTRUCTION MANUAL**

**BE IT ENACTED BY THE MAYOR AND COUNCIL OF THE TOWN OF MIDDLETOWN** (a majority of the members elected thereto concurring therein):

**Section 1.** That the Town of Middletown, Delaware, Code of Ordinances, Chapter 46: Construction Manual, is hereby amended as follows: See attached redacted and inserted document with changes / additions / deletions.

**Section 2.** This Ordinance shall become effective immediately upon passage.

ADOPTED THIS \_\_\_\_\_ DAY OF DECEMBER, 2021.

(SEAL)

\_\_\_\_\_  
Kenneth L. Branner, Jr., MAYOR

ATTESTED TO BY:

\_\_\_\_\_  
WITNESS, TOWN OF MIDDLETOWN



## **CHAPTER 46**

# **Manual of Construction Specifications and Details for Roads, Open Space and Utilities**

**Town of Middletown**

**[2021 Edition]**

## TABLE OF CONTENTS

Chapter 46-1 Streets Chapter

46-2 Sanitary Sewer Chapter

46-3 Water

Chapter 46-4 Open Space/Recreation

Supplemental Tracer Wire Specification

Chapter 46-5 Construction Details Section

### D – Storm Drainage Details

- D-1 Straight Headwall
- D-2 Standard Headwall (48", 54", & 60" Pipe)
- D-3 45° Standard Headwall (66" to 84" Pipe)
- D-4 Straight Headwall (Horizontal Elliptical Concrete Pipe)
- D-5 Straight Headwall (Metal Arch Pipe)
- D-6 "L" Headwall
- D-7 "L" Headwall (Metal Arch Pipe)
- D-8 Partial Pipe Cradle
- D-9 Standard Manhole Frame and Cover

### Section R – Road Details

- R-1 Pavement Tie-In Section
- R-2 Sidewalk
- R-3 Residential Entrance (with Grass Strip)
- R-4 Residential Entrance (without Grass Strip)
- R-5 Residential Driveway Section (Concrete)
- R-6 Residential Driveway Section (Asphalt)
- R-7 Temporary [Temporary] Roadway Patch
- R-8 Permanent Roadway Patch
- R-9 Forestry Lane
- R-10 Street Name Signs (Blades)
- R-11 Granite Curb Replacement

### Section S – Sanitary Sewer Details

- S-1 Pipe Bedding & Trench Detail
- S-2 Standard 48" Precast Concrete Manhole [(Private)]
- S-3 Standard 60" Precast Concrete Manhole
- S-4 Inside Drop Manhole Connection
- S-5 Standard Manhole Frame and Cover
- S-6 Sanitary Sewer Manhole Steps
- S-7 Water Main Clearance
- S-8 4" and 6" Drop House Connection (New Construction)
- S-9 Typical ~~Canalization~~ [Channelization] of Mainline Sewer Manholes
- S-10 Concrete Encasement and Cradle
- S-11 Concrete Encasement at Utility Crossings

- S-12 Concrete Manhole Collar (Paved Areas)
- S-13 Concrete Manhole Collar (Non-Paved Areas)
- S-14 Manhole Frame Replacement
- S-15 Riser Ring Detail
- S-16 Typical Cleanout
- S-17 Sewer House Connection (New Construction)
- S-18 Standard House Connection (Existing Sewer Main)
- [S-18-A Lateral Connection Detail
- S-19 Grease Trap
- S-20 Terminal Cleanout Force Main]

Section W – Water Details

- W-1 Standard Service Connection with Curb Box
- W-2 Water Main Crossing Storm & Sanitary Sewer
- W-3 [Water Main] Pipe Bedding & Trench Detail
- W-4 Standard Fire Hydrant Installation
- W-5 Thrust Blocks for Horizontal Bends
- W-6 Thrust Blocks for Tees & Tapping Sleeves
- W-7 Thrust Blocks for Plugs & Caps
- W-8 Anchorage for 1/32, 1/16, & 1/8 Upper Vertical Bends
- W-9 Thrust Blocks for 1/32, 1/16, & 1/8 Lower Vertical Bends
- W-10 Standard Flushing Hydrant
- W-11 Temporary Cap & Blow-off
- W-12 Meter Pit Setter (1", 1/2" & 2") [Typical Meter Pit Installation (3/4" to 2")]
- W-13 Typical Detector Check Valve for Fire Service and 3/4" to 2" Max. Domestic Meter (In Pit) [Combined Fire & Domestic Service Water Meter Assembly (In Pit)]
- W-14 Combined Compact Fire & Domestic Service Water Meter Assemblies (Reduced Size Meter Pit)[Separate Fire Service and Domestic Meter (In Pit)]
- W-15 Concrete Collar for Water Main Valves
- [W-16 Permanent Road Patching Detail for Water Mains]



**CHAPTER 46-1**  
**STREETS**

## **INTENT**

The intent of this article is to outline the requirements for the construction of streets within the Town of Middletown. Unless specifically stated herewith, all materials, equipment, design, details and construction methods associated with the construction of streets within the Town of Middletown shall conform to the latest editions of the manuals, specifications and guidelines of the Delaware Department of Transportation.

## **BITUMINOUS PAVEMENT**

### **Description**

- A. The paving of all streets and entrances to driveways and parking area within the Town of Middletown right-of-way shall be constructed as shown on the final approved plan and in accordance with the following standards.

### **Minimum Slope Requirements**

- A. The minimum lateral cross slope for all streets shall be 2.0% as measured from the centerline of the street to the edge of pavement. The minimum longitudinal slope, as measured along the centerline of the street, shall be 0.50%.

### **Soils Investigation Requirements**

- A. In the event the Town of Middletown determines a soil investigation is necessary, a geotechnical engineer registered in the State of Delaware with experience in pavement engineering shall perform the soils investigation. The Developer shall be responsible for the cost of the soil investigation. Boring locations, sampling procedures and method of testing shall be approved by the Town of Middletown and in accordance with the latest procedures found in the Delaware Department of Transportation Materials Manual. The Developer shall be responsible for stabilizing all weak and wet sub-grade prior to construction of the crushed aggregate base course.
- B. If weak or wet areas are suspected or encountered during construction, the Town of Middletown reserves the right to require a soils investigation as stated above, or require additional borings and testing if a report was prepared prior to construction. If the soils are found to be extremely weak with a soil resilient modulus less than 3400 psi, the Town of Middletown reserves the right to require an in-depth soils strength analysis and a specific pavement design that will satisfactorily address the specific situation. The Developer shall be responsible for all costs associated with the investigation and design.
- C. In the event unsuitable soils are encountered during the installation of a utility within the street right-of-way, the Town of Middletown reserves the right to require the placement of backfill material meeting the most recent specifications of the Delaware Department of Transportation. All costs associated with the placement of backfill shall be the responsibility of the Developer.
- D. In the event that streets are to be constructed in areas that require the removal of unsuitable material, the Town of Middletown reserves the right to request an

investigation to determine the extent of the unsuitable material to be removed. The Developer shall be responsible for all costs associated with the investigation.

**Pavement Construction Material and Thickness Requirements**

- A. Pavements shall be designed based on the assumption of poor soil conditions. All proposed streets shall be constructed, at a minimum, to the required type of materials and thickness of layers as specified in the tables below. If any street is expected to serve additional traffic in the future, such as an extension to a future development or tie-in to another development, the anticipated future increase in traffic shall be incorporated into the design.
- B. For developments larger than 500 residential units or 2,000,000 square feet of industrial/commercial building space, the Developer shall contact the Town of Middletown for pavement design requirements necessary to meet the specific situation.

**Minimum Material Type and Layer Thickness Requirements**

**Residential Street: Up to 500 Units**

Pavement Layer	Thickness	
Wearing (Surface) Course	2 in.	
Binder Course	3 in.	
Bit. Conc. Base Conc.	4 in.	
Aggregate Subbase	9 in.	
Structural Number	4.29 [4.54]	
Geotextile Separator	Optional (To be determined by Town of Middletown)	

**Commercial Street: Up to 2,000,000 Square Feet**

Pavement Layer	Thickness	
Wearing (Surface) Course	2 in.	
Binder Course	3 1/4 in.	
Bit. Conc. Base Conc.	5 in.	
Aggregate Subbase	12 in.	
Structural Number	5.04 [5.38]	
Geotextile Separator	Optional (To be determined by the Town of Middletown)	

**Subgrade Verification Requirements**

- A. After the Developer has prepared the soil subgrade in accordance with the Town of Middletown Street Construction Specifications, a proof roll of the prepared subgrade shall be required prior to placing the geotextile separator (if required) and asphalt base course. Density testing to verify compaction shall be performed in the field as directed by the Town of Middletown. All costs associated with compaction testing shall be paid by the Developer.
  
- B. A proof roll of the prepared subgrade and crushed aggregate base course shall be performed prior to the placing of the geotextile separator (if applicable) and asphalt base course. The proof rolling shall consist of a triaxial dump truck fully loaded to the maximum allowed weight (a certified delivery slip from the quarry shall be required to verify the weight). The truck shall be required to run the entire street subgrade including curb lines, over all trenches and anywhere directed by the Town of Middletown inspector. Areas displaying movement, pumping, pronounced elasticity or deformation under the loaded triaxial dump truck will be considered unstable and will be noted and or marked. The areas marked and or noted showing unstable subgrade shall be corrected and re-verified for the required stability prior to placing the geotextile separator (if applicable) and asphalt base course.
  
- C. A Town of Middletown inspector shall perform an inspection to verify the grade elevations of the subgrade and crushed aggregate base course prior to placement of the geotextile separator (if applicable) and asphalt base course. Contractor shall ensure that sufficient grade stakes are in place to allow for the appropriate measurements. Any areas that are not at the proposed design grade shall be corrected and re-inspected prior to placing the geotextile separator (if applicable) and asphalt base course.

**[Joint Sealing**

- A. Joint sealing of longitudinal joints and pipe trenches are required.]

**STREET SIGNS**

**Description**

- A. All signs, including regulatory, warning, directional and street signs shall be installed in accordance with the final approved plans and in conformity with the requirements of these Specifications and the Delaware Department of Transportation. In the event field conditions create difficulty adhering to the approved plans or specifications, the Developer shall install the signs in accordance with the direction provided by the Town of Middletown.

All signs installed within the Town of Middletown shall meet the reflective requirements of the Delaware Department of Transportation.

**Sign Posts**

- A. All street name sign posts shall be 2 3/8" diameter hot dipped galvanized steel round pipe. Sign posts for all other signs including regulatory, warning, parking and speed limit signs shall be hot dipped galvanized square channel with 3/8" holes on 1" centers in accordance with DeIDOT standards. [Street Signs shall be installed on a telescoping sign post which shall be supplied and installed as a complete unit inclusive of one (1) specified length of 2 inch square sign post, one (1) 36 inch x 2-1/4 inch base post, one (1) 18 inch x 2-1/2 inch base post, one (1) corner bolt and one (1) nut. Sign post materials shall be in accordance with Section 1072 of the current edition of the DeIDOT Standard Specifications for Road and Bridge Construction.]

- B. The minimum distance from the final grade to the bottom of the sign shall be seven (7) feet.

- [C. Street signs within residential communities are to be installed prior to the placement of the binder course of Hot Mix Asphalt.]

**Street Name Signs (Blades)**

- A. Street name signs shall be ordered by the Developer.
- B. Street name signs shall be steel plates stamped black on a white background. The lettering shall be four (4) inches high on a background six (6) inches high. Compass and street abbreviations shall be two (2) inches high. [as follows:

1. Size: 24" Wide by 6" Tall
2. Background: White Reflective, High Intensity Prismatic (HIP) meeting ASTM D4956 Type IV
3. Blade Material: Flat 0.080" Double-Sided Engineering Grade Reflective Aluminum with 3/4" radius corners.

4. Text Font: Highway Gothic Narrow

5. Text Color: Black Vinyl

6. Border Color: Black Vinyl

7. Warranty: 10 Year]

C. Street name signs shall be manufactured by the Gopher Sign Company, 1310 Randolph Avenue, St. Paul, MN 55105, or approved equal. [Colors shall meet Official MUTCD Standards.]

### **STOP Signs**

A. STOP signs shall be an octagon, ~~30 x 30~~ [36 x 36] inches, with a white message and border on a red background.

### **LIGHTING**

#### **Description**

- A. The Town of Middletown Electric Department is responsible for coordinating the street light design, purchasing all materials and installation. The Town of Middletown is responsible for selecting the type of lights installed.
- B. It shall be the responsibility of the Developer to pay the Town of Middletown for all costs associated with the installation of street lights including design, material and labor.

### **CURB AND GUTTER**

#### **Description**

- A. All streets dedicated to the Town of Middletown shall be constructed with Integral P.C.C. Curb and Gutter, Type 3 in accordance with the standards and specifications of the Delaware Department of Transportation. All other types of curb and gutter shall only be permitted with written approval by the Town of Middletown.
- [B. Unless authorized by the Town of Middletown, existing granite curb may not be replaced with any other type of curbing materials, except that granite curbs may be replaced by concrete curbs where necessary to facilitate the construction of a ramp for ADA access to and from the adjoining street. Granite curbing, when authorized to be removed by the Town, shall be delivered to and stored on Town property at a location or locations designated by the Department of Public Works.]

### **DRAINAGE PIPE**

#### **Description**

- A. All drainage pipe installed within the dedicated Town of Middletown right-of-way shall be Reinforced Concrete Pipe.

- B. Video taped inspection of the completed storm drainage system shall conform to the standards and specifications of the Delaware Department of Transportation.
- C. Upon completion of all drainage, and prior to acceptance, as-built drawings shall be submitted to the Town of Middletown for review and approval. One electronic copy in .pdf format shall be submitted bearing the signature and seal of a Delaware registered surveyor or engineer with the same scale as the original approved drawings.
- [D. Storm Sewer Pipes at structures, which are less than one-half of a full pipe length, are to be set on a concrete cradle from the joint to the face of the structure.]**
- E. Inlet and outlet pipes shall extend through, and be flush with, the inside of the structure wall. When cutting off the end of a reinforced concrete pipe, finish with mortar so that no reinforcement steel remains exposed. Fill any space between the pipe and the walls of the drainage structure with solid brick and non-shrink grout conforming to the requirements of ASTM C1107 Grade C, with a minimum strength of 5,000 PSI. Ensure that the pipe opening in the drainage structure is no more than 4 inches larger than the pipe diameter measured from the outside pipe wall. Non-shrink grout shall be given a minimum of four (4) hours to cure prior to backfill being placed at the pipe connection. A concrete collar at the pipe connection may be installed in the event that the backfill must be placed prior to achieving the minimum four (4) hour cure time.]**

**CATCH BASINS**

**Description**

- A. Catch basin submittals shall be submitted to the Town of Middletown for review and approval for all structures that are not in conformance with the standard specifications of the Delaware Department of Transportation.
- B. A storm drain marker bearing the words “Don’t Pollute Flows to Waterways” as manufactured by Das Manufacturing, or approved equal, shall be installed on all catch basins prior to final acceptance. The Developer shall follow all manufacturers specifications for the installation.

**SPEED BUMPS**

**Description**

- A. Speed bumps shall be prohibited within all right-of-way dedicated to the Town of Middletown.

**ROADWAY MARKINGS**

**Description**

- A. All roadway markings, including but not limited to stop bars, centerline and lane line striping, crosswalk striping and symbols shall be thermoplastic. Paint and epoxy resin will not be permitted.]**

**CHAPTER 46-2**  
**SANITARY SEWER**



## INTENT

The intent of this article is to outline the requirements for the construction of sanitary sewer within the Town of Middletown. Unless specifically stated herewith, all materials, equipment, design, details, testing and construction methods associated with the construction of sanitary sewer within the Town of Middletown shall conform to the latest specifications and details of New Castle County.

## SANITARY SEWER GRAVITY MAINS AND HOUSE CONNECTIONS

### **Description**

- A. This section shall consist of gravity sanitary sewers mains and house connections within the right-of-way or a Town maintained easement of ductile iron pipe (DIP) or polyvinyl chloride (PVC) pipe of the diameter shown on the Plans, laid on a firm bed true to line and grade in accordance with these Specifications and Details. No other materials shall be allowed to be used for gravity sewer installation without written approval by the Town of Middletown.

### **Materials**

- A. Polyvinyl Chloride (PVC) Pipe. PVC pipe, used for gravity sewer construction, shall equal or exceed the requirements of ASTM D-3034 and shall have a minimum Standard Dimension Ratio (SDR) of 26 and the minimum pipe stiffness, as tested in accordance with ASTM D-2412, shall be 45 psi when measured under 5 percent deflection at 73 degrees Fahrenheit. Pipe shall be manufactured with integral wall bell and spigot joints in standard lengths not exceeding twenty (20) feet.

Polyvinyl Chloride (PVC) pipe fittings shall utilize an elastomeric O-ring gasketed joint assembly in accordance with the manufacturer's recommendations.

Polyvinyl Chloride (PVC) Wye, ~~T~~ [45 degree] Wye branches, pipe stoppers and other fittings shall be manufactured in accordance with the same specifications and shall have the same thickness, depth of socket, and annular space as the main pipe. Wye and ~~T~~ [45 degree] Wye branches shall be complete pipe sections.

Service saddles will not be permitted for use in new construction.

Polyvinyl Chloride (PVC) pipe shall be delivered and stockpiled in unit pallets. No stacking of pallets above 5 feet in height will be allowed. If pipe is stockpiled for more than 30 days prior to installation, it must be suitably covered with reflective material to protect the pipe from ultra-violet rays emanating from sunlight. Do not use plastic sheets. Allow for air circulation under covering.

Bowed sections of pipe will be unacceptable. Installation of pipe which has bowed, whether or not the bow has been corrected, will not be allowed.

- B. Ductile Iron (DIP) Pipe. DIP pipe shall be manufactured in accordance with

ANSI A21.51, latest edition, and shall be thickness Class 52 unless otherwise approved by the Town. ~~The contractor shall have the option of furnishing mechanical or push-on joints conforming to ANSI A21.11, latest edition; [shall be utilized for gravity sanitary sewer applications.]~~

Pipe and fittings shall be double cement lined with seal coat and shall receive an external standard bituminous foundry coating in accordance with ANSI A21.4. ~~[The Pipe and fittings shall also have an internal coating system. The internal coating shall be a ceramic epoxy and shall be an amine cured novalac epoxy containing at least 20% by volume of ceramic quartz pigment. The coating shall be US Pipe and Foundry Protecto 401 or an approved equal.]~~

Gravity sewer mains installed at depths exceeding ~~18~~ [15] feet shall ~~be required to be ductile iron pipe.~~ [not be permitted unless approved in writing by the Town of Middletown based on extenuating circumstances that cannot be avoided. Before the Town will consider sewer deeper than fifteen (15) feet, the engineer must consider and present alternatives to the Town which shall include, but not be limited to, 1) the installation of a pump station and forcemain, 2) realignment of the sewer main to avoid the excessive depth, and 3) adjustment of the site grading to reduce or eliminate the excessive depth.]

All fittings used to connect ductile iron sewer main pipe shall be ductile iron with a 250 psi pressure rating and marked in accordance with ANSI A21.10.

- C. Sanitary Sewer Lateral Cleanout Frames and Covers. Cleanout frames and covers shall be cast iron. Cleanout frames and covers shall be water tight with recessed lifting holes. Terminal sewer and house lateral cleanout frames and covers shall be brass caps used with PVC pipe.
- D. Detection Tape. Pipeline detectable tape shall be installed continuously along all gravity sewers. The tape shall be installed directly above the gravity sewers and 24 inches below the ground surface. The tape shall be Lineguard Type III Detectable Tape as manufactured by Lineguard, Inc., of Wheaton, Illinois, or equal. The tape shall be a minimum of two inches wide, green in color, imprinted with the words **“Caution-Sewer Line Below”**, and be capable of being detected with inductive methods.
- E. Concrete. All concrete for manhole base slabs and cradles, flow channels, encasements, blocking, etc., shall have a minimum compressive strength of 3,000 psi at 28 days. Type II Portland Cement shall be used.
- F. Sand. Sand shall be composed of sharp, angular, siliceous grains, coarse, or graded from fine to coarse with the coarsest grains predominating, and sensibly free from clay, loam, dirt, mica, organic matter, or other impurities.

Sand containing more than 5 percent by weight of foreign material shall not be used. This limit may be changed for special classes of work if hereinafter specified.

Sand exhibiting more than an acceptable amount of fine matter or impurities may be required to be washed after delivery or shall be rejected altogether. The

Contractor shall submit samples of the sand he proposes using. These shall be retained in the office of the Inspection Agency as a standard for comparison during the progress of the work, and all sand used shall be equal in quality to the acceptable samples. Sand for mortar shall be screened to reject all particles of a greater diameter than 1/4 inch and shall not contain more than 5 percent by weight of a very fine material.

- G. Mortar. Cements shall be Class B Sulfur resistant in accordance with the "Standard Specifications for Portland Cement," ASTM Designation C 150 for Type II.

Unless hereinafter specified otherwise, all mortar shall be composed of cement and sand of the character specified above. The proportion by volume shall be one part of cement to two parts of sand. One volume of cement shall be 94 pounds net. One volume of sand shall be 0.9 cubic feet, the sand not being packed more closely than by throwing it into a box in the usual way. Mortar shall be fresh mixed in small batches for the work in hand. Tight boxes or platforms made for the purposes shall be used. The sand and cement shall be thoroughly mixed dry, in the proper proportions, until a uniform color has been produced, whereupon a moderate dose of water shall be added, so as to produce a stiff paste of the proper consistency.

Sand obtained from the excavation shall not be used.

### **Construction Methods**

- A. Topsoil, vegetative matter, and other organic material shall be stripped from areas that are to be disturbed by construction, and stockpiled. Topsoil shall be segregated from non-organic trench excavation material and debris.

Trench backfill material shall be satisfactory soil excavated from the trench, or imported soil meeting DelDOT specifications for trench backfill. Satisfactory trench backfill shall be free from frozen matter, stumps, roots, brush, other organic matter, cinders or other corrosive material, debris, and any rocks or stone larger than 6 inches, in any dimension. Material that is excessively wet and or unable to compact in a satisfactory manner will not be placed for backfill. The Town of Middletown Inspection Department will direct the contractor to stop installation and backfilling operations if proper compaction is not achieved.

- B. Laying Pipe. Pipe shall be carefully handled and lowered into the trench. In laying pipe, special care shall be taken to ensure that each length shall abut against the next in such a manner that there shall be no shoulder or unevenness of any kind along the inside of the bottom half of the pipe line. No wedging or blocking will be permitted in laying any pipe unless by written order or permission from the Town.

Before joints are made, each pipe shall be well bedded on a solid foundation, and no pipe shall be brought into position until the preceding length has been thoroughly embedded and secured in place with a minimum of 6 inches of crushed angular stone, 3/4 inch maximum size [ , or #57 Stone.] The Contractor

shall make any defects due to settlement good. Bell holes shall be dug sufficiently large enough to ensure that the pipe is firmly bedded on the full length of the barrel.

Proper and suitable tools and appliances for the safe and convenient handling and laying of pipes shall be used.

The pipes shall be thoroughly cleaned before they are laid and shall be kept clean until the acceptance of the completed work. The open ends of all pipelines shall be provided with a stopper carefully fitted, so as to keep dirt and other substances from entering. This stopper shall be kept in the end of the pipe line at all times when not in the process on laying pipe.

Whenever a pipe requires cutting to fit into the line or to bring it to the required location, the work shall be done in a satisfactory manner so as to leave a smooth end, without extra compensation.

All concrete required to support and reinforce Wye branches and bends shall be placed as shown in the Standard Details or as directed by the Town.

All sewer house connections shall be laid on a two (2) percent grade unless otherwise directed. All house connections shall meet the requirements of the Town of Middletown's adopted Plumbing Code unless otherwise directed by the Town.

[All sewer house connections shall be surrounded by No. 57 stone (to a minimum depth of six (6) inches on all sides) from the connection at the sewer main all the way to the cleanout at the property line/right-of-way.]

All sewer house connections shall be constructed to terminate at an angle perpendicular to the property lines unless otherwise noted on the plans.

The excavation in which pipe is being laid shall be kept free from water and no joint shall be made under water. Water shall not be allowed to rise in the excavation until pipe bedding and backfill has been completed. The greatest care shall be used to secure water tightness and to prevent damage to, or disturbing of, the joints during the backfilling process, or at any time. After pipes have been laid and the joints have been made, there shall be no walking on or working over them except such as may be necessary in tamping, until there is a covering at least two feet in depth, over their top.

All pipe shall be placed in accordance with the installation recommendations of the pipe manufacturer and applicable portions of this Specification.

No pipe shall be laid upon a foundation into which frost has penetrated at any time such that there is danger of the formation of ice or the penetration of frost at the bottom of the excavation, unless the minimum length of open trench and promptness of refilling are observed.

Branches shall be located in a position designated by the Developer's Engineer or

his representative. Short pieces of lateral sewer shall be field-cut to meet this condition. The Contractor shall have on the work site, at all times, factory approved equipment to machine and adapt the field-cut end of short pieces to standard couplings and jointing materials.

Minimum depth of cover for any sewer main shall be 42 inches measured from the top of the pipe to the final grade above the pipe.

- C. Backfill and Compaction. All trench backfill shall be compacted. Backfill of pipe and manholes shall be compacted with equipment in a manner which is capable of producing the required results. Backfill material shall be placed and graded in uniform horizontal lifts, which may not exceed 8 inches. Compaction will not be performed by jetting or water settling. If during the compaction of the trench, any soft, yielding, or spongy areas are observed, backfilling operations will cease until stability of these areas is achieved. The Town of Middletown has the authority to request field moisture/density control tests to document compliance of work as per DeIDOT's specifications. Failed areas shall be compacted again and retested. A Geotechnical Consultant approved by the Town of Middletown shall perform moisture/density tests at the Developer's expense.
- D. Connection to Existing Manholes. Connection to existing manholes shall be made at such points and of such form, dimensions and elevations as indicated on the Plans or as the Town of Middletown shall require.

The size of the opening through the wall of the existing manhole for the pipeline connections shall not exceed the outside diameter of the pipe plus 6 inches. All connections shall be fully grouted by using ~~a non-shrinking grout.~~ [hydraulic cement with a sand collar or a Link-Seal / Boot type system. Sand collars will not be permitted in deep (greater than 10 feet below ground surface) or high groundwater conditions] Manhole adapters shall be used on all connections to existing manholes.

Care shall be taken by the Contractor to prevent broken brick and mortar from entering the existing or proposed pipes. A screen shall be provided below the area of work to catch any falling debris.

Core drilling is the only acceptable method of making a new opening in an existing reinforced concrete manhole.

### **Alignment**

- A. Sanitary sewers shall be installed with straight horizontal and vertical alignments between manholes. When a smaller sewer joins a larger one, the invert of the larger sewer should be lower to allow the crowns of both pipes to be at the same elevation. The invert of a pipe exiting a manhole shall be lowered the appropriate distance compared to the invert of the pipe(s) entering the manhole to account for the head loss within the manhole.

### **Storm Drain Separation**

- A. Sanitary sewers shall be laid at least 3 feet horizontally from any storm drain pipe measured edge to edge. Sanitary sewer mains that cross a drainage pipe shall be encased in concrete, a minimum of five (5) feet on either side of the centerline of the crossing, if there is less than two (2) feet of clearance between the outside diameter of the sanitary sewer and the outside diameter of the drainage pipe. A full length of sanitary sewer pipe shall be installed centered on the storm drain to maximize the distance to a sanitary sewer pipe joint.

### **Horizontal and Vertical Separation.**

- A. In general, horizontal and vertical separation shall be per 10 States Standards. Sewer mains shall be laid at least ten (10) feet horizontally from any existing or proposed water main. The distance shall be measured edge to edge. Separation between sewer and water laterals shall be a minimum of three (3) feet measured inside edge to inside edge, or as required in the adopted plumbing code, whichever is stricter.
- B. Sewers crossing water mains shall be laid to provide a minimum vertical distance of eighteen (18) inches between the outside of the water main and the outside of the sewer.
  - a. Sewer lines shall be located below water mains unless otherwise authorized by the Town.
  - b. When a sewer main crosses an existing water main, the crossing shall be arranged so that the sewer joints will be equidistant and as far as possible from the water main joints.
  - c. Where a water main crosses under a sewer, adequate structural support shall be provided for the sewer to maintain line and grade and prevent damage to the water main.
  - d. When it is impossible to obtain proper horizontal and vertical separations stipulated above, the Town may allow deviations on a case-by-case basis, if supported by data from the Design Engineer. Alternate design shall meet 10 State Standards.

### **Acceptance Testing**

- A. Prior to the request for final acceptance by the Town, it shall be the Contractor's responsibility to examine all completed pipe lines to insure that they are laid to the proper alignment and grade and free from foreign material. After this has been done to the satisfaction of the Town, the Town will order tests to be made on all portions of the sewers built under the Contract. The Contractor shall cooperate and furnish all assistance necessary to perform the tests as specified herein and as directed by, and under the direction of the Town's inspector.
  - 1. Deflection Testing of Sanitary Sewers – Sanitary sewers shall be tested in the presence of the Town's inspector and the Contractor's representatives to determine the amount of vertical deflection in the completed pipe line as follows:

Deflection testing as specified hereinafter shall be accomplished by the Contractor on all sanitary sewers installed. Should significant failures be detected, additional deflection testing shall be performed by the Contractor.

Installation of sanitary sewers shall be complete prior to the start of deflection testing. All sheeting shall be removed except where written approval from the Town to keep the sheeting has been obtained. All backfill shall be placed to finished grade and dewatering operations ceased.

A mandrel with a diameter equivalent to 95 percent of the inside diameter of the pipe to be tested shall be pulled through the pipeline, from manhole to manhole, by hand. If the ~~steel ball~~ [mandrel] is unable to pass through the pipe without applying excessive force (as judged by the Town), it will be constructed as evidence that the pipe has deflected more than 5 percent of the inside pipe diameter. A permanent record of all testing with locations where excessive pipeline deflections occur shall be kept by the Contractor and forwarded to the Inspection Agency after completion of testing on each line. The mandrel shall be approved by the Inspection Agency prior to use. Mandrels shall have an odd number of gauging plates. The minimum number of plates shall be nine (9) with a contact surface length equal to the inside pipe diameter plus two (2) inches for pipelines 10 inches in diameter and smaller. On larger diameters, the contact surface length shall equal the inside pipe diameter.

The Contractor shall immediately replace all sections of pipe which deflect more than 5 percent.

2. Air Acceptance Test – The Town of Middletown reserves the right to utilize a low pressure air acceptance test for pipe with a diameter of 39 inches or less. The Contractor shall furnish all equipment and personnel to conduct this test in accordance with [ASTM F1417 – 92 and] the following procedure:
  - a. All branch fittings and ends of lateral stubs shall be securely plugged to withstand the internal test pressures. The section of line being tested shall also be securely plugged at each manhole. All stoppers shall be adequately braced when required.
  - b. Air shall be slowly supplied to the plugged pipe line until the internal air pressure reaches 5.0 [4.0] pounds per square inch [psi] greater than the average back pressure of any ground water that may submerge the pipe. This pressure shall remain for a minimum of six (6) minutes with no drop in pressure. [and the test pipe section is stabilized.]
  - c. Disconnect the air supply and decrease the pressure to 3.5 psi before starting the test.
  - d. The pressure within the test pipe section must remain at or above 3.0 psi for the minimum holding time based on Table 2 below:

TABLE 2 Minimum Specified Time Required for a 0.5 psig Pressure Drop for Size and Length of Pipe Indicated for Q = 0.0015											
Note - Consult with pipe and appurtenance manufacturer for maximum test pressure for pipe size greater than 30 in. in diameter.											
Pipe Diameter (in)	Minimum Time (min:sec)	Length for Minimum Time (ft)	Time for Longer Length (sec)	Specification Time for Length (L) Shown (min:sec)							
				100 ft	150 ft	200 ft	250 ft	300 ft	350 ft	400 ft	450 ft
4	1:53	597	0.190 L	1:53	1:53	1:53	1:53	1:53	1:53	1:53	1:53
6	2:50	398	0.427 L	2:50	2:50	2:50	2:50	2:50	2:50	2:51	3:12
8	3:47	298	0.760 L	3:47	3:47	3:47	3:47	3:48	4:26	5:04	5:42
10	4:43	239	1.187 L	4:43	4:43	4:43	4:57	5:56	6:55	7:54	8:54
12	5:40	199	1.709 L	5:40	5:40	5:42	7:08	8:33	9:58	11:24	12:50
15	7:05	159	2.671 L	7:05	7:05	8:54	11:08	13:21	15:35	17:48	20:02
18	8:30	133	3.846 L	8:30	9:37	12:49	16:01	19:14	22:26	25:38	28:51
21	9:55	114	5.235 L	9:55	13:05	17:27	21:49	26:11	30:32	34:54	39:16
24	11:20	99	6.837 L	11:24	17:57	22:48	28:30	34:11	39:53	45:35	51:17
27	12:45	88	8.653 L	14:25	21:38	28:51	36:04	43:16	50:30	57:42	64:54
30	14:10	80	10.683 L	17:48	26:43	35:37	44:31	53:25	62:19	71:13	80:07
33	15:35	72	12.926 L	21:33	32:19	43:56	53:52	64:38	75:24	86:10	96:57
36	17:00	66	15.384 L	25:39	38:28	51:17	64:06	76:55	89:44	102:34	115:23

- e. Upon completion of the test, open the bleeder valve and allow all air to escape. Plugs should not be removed until the air pressure in the test section has been reduced to atmospheric pressure.]

The Contractor shall be responsible to repair all defects in the event the pipe is unable to maintain pressure.

The Contractor shall not make any [active] connections to the existing sanitary sewers until after the acceptance tests have been performed and approved by the Town.

3. Camera Inspection

The Town of Middletown reserves the right to require a TV inspection of sewer mains and laterals. This inspection will take place as a final punch list item and before top lift of hot-mix is placed.

Inspection shall be performed by a NASSCO Pipeline Assessment Certification Program (PACP) certified operator and shall meet the coding and reporting standards and guidelines as set by PACP. These same standards shall also be used for lateral inspections regardless of whether conducted using cleanout launched or mainline launched lateral camera. All report annotations, pipe conditions and pipe defects shall be identified properly using PACP codes as defined by PACP, and severity ratings shall be calculated according to PACP.

Quality of inspection recording shall be acceptable to the Town when viewed on a standard computer monitor.

Submittal of PACP certificate to Town of Middletown inspectors completing the work shall be required.



Closed Circuit TV Equipment: Select and use closed-circuit television equipment that will produce a color recording.

Pipe Inspection Camera: Produce video recording using a pan-and-tilt, radial viewing, pipe inspection camera that pans  $\pm 275$  degrees and rotates 360 degrees. Use a camera with an accurate footage counter that displays on the TV monitor the exact distance of the camera from the centerline of the starting manhole. Use a camera with camera height adjustment so that the camera lens is always centered at one-half the inside diameter, or higher, in the pipe being televised. Provide a lighting system that allows the features and condition of the pipe to be clearly seen. A reflector in front of the camera may be required to enhance lighting in large diameter pipe. Lighting shall not cause shadows within the field of view of the camera, either when forward viewing or when using pan/tilt. The camera, television monitor and other components of the video system shall be capable of producing a minimum 500-line resolution colored video picture. Picture quality and definition shall be to the satisfaction of the Town.

Mainline Launched Lateral Inspection Camera: Produce a video recording using a fixed orientation color camera capable of extending into open laterals for a minimum distance of 80 feet from the lateral connection. Minimum performance standards are as noted above in Pipe Inspection Camera.

Lateral Cleanout Launched Lateral Inspection Camera: Alternatively, Contractor may produce a video recording of the sewer lateral between the sewer lateral cleanout and the mainline using a mini-cam launched from the sewer lateral cleanout. Minimum performance standards are as noted above in Pipe Inspection Camera.

TV Studio: TV studio is to be contained in an enclosed truck, trailer or van. It shall have room and seating for the operator and the Town and also room for at least one standing visitor with the doors closed. The studio shall have air conditioning and heating. Normal operation of all equipment, including the TV camera, monitor, and winches is to be from a control panel in the studio. When joint testing and sealing is to be performed, the equipment shall be contained in the same unit as its TV equipment and shall be operated from the same control panel.

Recording: All recordings are to be in digital format.

1. Image Capture – Digitized picture images shall be stored and be exportable as JPEG formats. Minimum resolution shall be 1024 x 768.
2. Video Capture – Full time live video and audio files shall be captured for each pipe segment and lateral inspected. The files shall be stored in industry standard MPEG format viewable from a DVD. The MPEG video shall be ISO-MPEG Level 1 (MPEG-1) coding with a resolution of 352 pixels (x) by 240 pixels (y) and an encoded frame rate of 29.97 frames per second. System shall perform an automatic disk image/file naming structure to allow saved video/data

sections to be “burned” to digital format. It shall have the capability of “burning” a minimum of 120 minutes of recording to digital media. The video recording shall be free of electrical interference and shall produce a clear and stable image. The audio recording shall be sufficiently free of background and electrical noise as to produce an oral report that is clear and discernable. The digital recordings and inspection data shall be cross-referenced to allow instant access to any point of interest within the digital recording.

#### Television Inspection: Additional requirements.

- a. Sewer lines and manholes are required to be clean. Prior to the television inspection, any sewer line or manhole found to be dirty during the TV inspection process will be cleaned by the Contractor.
- b. Televiser the sewer line to document the condition of the line. Provide a color recording showing the completed work.
- c. For mainline inspections, inspections shall be from center of the starting manhole to the center of the ending manhole. Distances along the pipe should be measured from the center of the upstream manhole.

The Contractor shall be responsible to repair all defects observed in the camera and television inspection prior to final acceptance by the Town of Middletown.

#### **As-Built Drawings**

- A. Upon completion of all sanitary sewer, and prior to acceptance, as-built drawings shall be submitted to the Town of Middletown for review and approval. One electronic copy in .pdf format shall be submitted bearing the signature and seal of a Delaware registered surveyor or engineer with the same scale as the original approved drawings.

#### **Minimum Size**

- A. No sewer main shall be less than eight (8) inches in diameter. The minimum size of a sewer lateral shall be six (6) inches. Apartments/condominiums up to four (4) units per cluster may use a six (6) inch diameter sewer lateral. Clusters with more than four (4) units shall use a lateral size based on a computation of the flow to be generated from the cluster.

#### **Minimum Slope**

- A. All sewers shall be designed and constructed to provide mean velocities, when full, of not less than two (2.0) feet per second. Based on Kutter’s formula or Manning’s formula, an “n” value of 0.013 is generally used. Use of other practical “n” values may be permitted if the available research or field data show

justification. The following are the minimum slopes that should be provided; however, slopes greater than these figures are desirable:

Sewer Size (inches)	Minimum Slopes ft./ft.
8	0.0050
10	0.0028
12	0.0022
15	0.0015
18	0.0012
21	0.0010
24	0.0008
27	0.00067
30	0.00058
36	0.00046

- B. All sewer laterals shall have a minimum slope of two (2) percent, or in accordance with the adopted plumbing code, whichever is stricter. Excessive slopes should be avoided to prevent the separation of solids and liquids in the pipe.

#### **Backflow Preventers**

- A. All sewer laterals between individual **residential** buildings and the sewer main shall have a backflow preventer installed prior to any branch line or internal cleanout. **[Sewer laterals serving non-residential buildings may be required to install a backflow preventer subject to review by the Town's Engineer.]**
- B. They shall be located inside the foundation wall for buildings with basements and just prior to the base wall in buildings with crawl spaces or no basements.
- C. The backflow preventer shall remain accessible to and installed ahead of any and all service lines or cleanouts.

#### **Cleanouts**

- A. All sewer laterals shall have cleanouts installed on the exterior located at or within two (2) feet of the property line and every fifty (50) feet between the property line and building.
- B. Only flush type cleanouts will be installed.
- C. No cleanout will be allowed to extend more than 1/2 inch above finished grade.
- D. Cleanouts shall, by means of a sweeping 45 degree elbow, be connected in the direction of flow to an installed Y on the lateral.
- E. Cleanouts installed in driveways or other roadway surfaces (blacktop areas) must be installed per the Town of Middletown Standard Details.

## **SANITARY SEWER FORCE MAINS**

### **Description.**

- A. This section shall consist of sanitary sewer force mains within the right-of-way or a Town maintained easement of ductile iron pipe (DIP), polyvinyl chloride (PVC) pipe or of high density polyethylene (HDPE) of the diameter shown on the Plans, laid on a firm bed true to line and grade in accordance with these Specifications and Details.
- B. Force mains shall be installed at the elevations indicated on the construction drawings. Force mains shall maintain a minimum of 42 inches of cover.

### **Materials**

- A. Polyvinyl Chloride (PVC) Pressure Pipe. All buried PVC pressure pipe shall be polyvinyl chloride pipe (PVC) Class 150-~~253~~ SDR-18 meeting the requirements of ASTM D-2241 ~~[for force mains up to 12" diameter]~~. Fittings shall be in accordance with ASTM D-2466 of the same color and pressure rating. Joints at the fittings shall be of the ~~solvent weld~~ ~~[mechanical joint]~~ type. At the remaining joints push-on type joints with concrete buttresses may be used in accordance with ASTM 3139. The elastomer seals used for joining the pipe shall meet ASTM F477 Specifications. Lubricant shall be as recommended and supplied by the pipe manufacturer.

Provide a joint restrainer for the connection to ductile iron pipe if thrust forces present dictate this requirement. Provide a joint restrainer at all locations where a transition to HDPE pipe is required. The restrainer shall provide a full 360-degree contact with a serrated inside surface to secure the clamp to the pipe. The restrainer shall be UNI-FLANGE Series 1300 or an approved equal for PVC to ductile iron transitions. The restrainer between PVC and HDPE pipe shall be per the recommendations of the HDPE pipe manufacturer.

- B. Ductile Iron (DIP) Pipe. All buried ductile iron piping shall be Pressure Class 52 ductile iron meeting the requirements of AWWA C151. The Pipe shall be double cement lined per AWWA C104 and have an internal coating system. The internal coating shall be a ceramic epoxy and shall be an amine cured novalac epoxy containing at least 20% by volume of ceramic quartz pigment. The coating shall be US Pipe and Foundry Protecto 401 or an approved equal. Pipe intended for buried installation shall receive an external standard bituminous foundry coating in accordance with ANSI A21.4. All buried ductile iron pipe shall have mechanical joints in accordance with AWWA C111.
  - a. All fittings shall be ductile iron compatible fittings with mechanical joints meeting the requirements of AWWA C153. All fittings shall be double cement lined per AWWA C104 and coated on the exterior with an asphaltic coating. The interior coating shall be the same as for the pipe, as noted above.
  - b. Provide restrained joints for all buried ductile iron pipe. Joints shall be suitable for use with AWWA C111 mechanical joints. The follower

gland shall include a restraining mechanism which, when actuated, imparts multiple wedging action against the pipe, increasing its resistance as the pressure increases. Flexibility of the joint shall be maintained after burial. Glands shall be manufactured of ductile iron conforming to ASTM A536-80. Restraining devices shall be of ductile iron heat treated to a minimum hardness of 370 BHN. Dimensions of tie gland shall be such that it can be used with standard mechanical joint with tee bolts. Twist-off nuts, sized same as tee-head bolts, shall be used to insure proper torque and actuating of restraining devices. The mechanical joint restraining device shall have a working pressure of at least 250 psi with a minimum safety factor of 2, and shall be EBAA Iron, Inc. MEGALUG, Mueller Aqua Grip, or approved equal.

- C. High Density Polyethylene (HDPE) Pipe. HDPE pipe used for force main construction, shall be PE3408 high density polyethylene meeting cell classification 345444C or 345444E per the requirements of ASTM D-3350 and shall be listed in the name of the pipe and fitting manufacturer in the Plastics Pipe Institute TR-4, Recommended Hydrostatic Strengths and Design Stresses for Thermoplastic Pipe and Fittings Compounds, with a standard HDB rating of 1600 psi at 73° F. Pipe and fittings shall be from the same manufacturer. Pipe shall be manufactured in accordance with ASTM F714 or ASTM D 3035 and shall be so marked. The pipe shall have a Standard Dimension Ratio (SDR) suitable for the design operating condition means of installation and depth of burial, as approved by the Town Engineer. HDPE force mains installed via the directional bore method shall be SDR 11.0, minimum.

### Pipe Detection

- A. Force mains shall have tracer wire and detectable tape installed continuously along its length. Detectable tape shall be installed in accordance with the specifications outlined in the section entitled "Sanitary Sewer Gravity Mains and House Connections". [The tape shall be a minimum of two inches wide, green in color, and imprinted with the words "Caution-Sewer Line Below".] Tracer wire shall be installed in accordance with the Town of Middletown "Supplemental Tracer Wire Specification."

### Thrust Blocks.

- A. Thrust blocks shall be provided on all force main plugs, caps, tees, and bends deflecting 22-1/2 degrees or more either vertically or horizontally.
1. Thrust blocks shall be concrete with a compressive strength of 3000 psi in 28 days.
  2. Thrust blocking shall be located between solid ground and the fitting to be anchored.
    - a. Unless otherwise shown or directed by the Town, place the base and thrust bearing sides of thrust blocking directly against undisturbed earth.
    - b. Place thrust blocking so the fitting joints will be accessible for

- repair.
- c. Protect steel rods and clamps by galvanizing or by coating with bituminous paint.

## **Valves**

- A. Plug valves for force main isolation service shall be the non-lubricated type designed for a minimum working pressure of 175 psi and suitable for buried service. The valve shall be suitable for tight closure with pressure on either side of the plug. Buried valves shall have mechanical joint ends. Valves installed in vaults shall have flanged ends unless otherwise noted. The body shall be semi-steel. The plug shall be semi-steel, resilient type neoprene faced for use in raw sewage service. The plug seat shall have an overlay of mechanical nickel, fusion-bonded Nylon II, or other suitable material on all surfaces in contact with the plug face. The port area of the valve shall not be less than 100% of the pipe area. The upper trunnion shall be sealed with either permanent "O"-ring type seals, or packing held in place by an adjustable packing gland. Packing shall be replaceable without disassembly of operator or valve. The upper and lower journals shall be fitted with replaceable permanently lubricated stainless steel sleeve type bearings. Valves shall be either hand wheel or 2-inch square nut operated as indicated on the Plans. Plug valves shall be manufactured by the DeZurik Unit of General Signal Corp. or an approved equal.
- B. All plug valves shall be furnished with buried service type gear operators. Buried valves shall be furnished with a roadway valve box and an extension stem securely fastened to the operator to position a 2-inch square operating nut welded to the top of the stem within 12 inches of the ground surface. An open and closed indicator shall be provided on all valves at the operating nut. Valves shall open left (counterclockwise). Spacer discs or rods shall be installed in the valve box as required to center the extension stem. Extension stem shall be of the size recommended by the valve manufacturer.
- C. The exterior of the valve, operator, and extension stem shall be bituminous coated unless otherwise noted.

## **Valve Boxes**

- A. Valve Boxes shall be cast iron, 3 piece screw type installed over the valve bonnet and operating nut. Valve boxes shall be capable of being adjusted to reach the surface of the existing or proposed grade but not to extend above the finished grade at any time. Valve boxes shall be manufactured by Mueller or approved equal.

## **Couplings and Wall Seals**

- A. Couplings shall be provided where required to facilitate the installation or removal of valves and equipment, in addition to the couplings shown on the drawings. All couplings shall be designed for the same pressure rating as of the pipes on which installed. In addition:
- B. The pipe couplings shall be of gasketed, sleeve-type, with diameter to properly fit

the pipe. Each coupling shall consist of one (1) steel middle ring 0.154 inches thick and 5 inches in length, two (2) steel followers, two (2) rubber-compounded wedge section gaskets and sufficient track-head steel bolts to properly compress the gaskets. Field joints shall be made with this type of coupling.

- C. The middle ring and followers of the coupling shall be true circular sections free from irregularities, flat spots, or surface defects. They shall be formed from mill sections with the follower-ring section of such design as to provide confinement of the gasket. After welding, they shall be tested by cold expanding a minimum of 1% beyond the yield point.
- D. The coupling bolts shall be of the elliptic-neck track head design with rolled threads. The manufacturer shall supply information as to the recommended torque to which the bolts shall be tightened. All bolt holes in the followers shall be oval.
- E. The gaskets of the coupling shall be composed of a crude or synthetic rubber base compounded with other products to produce material, which will not deteriorate from age, from heat, or exposure to air under normal storage conditions. It shall also possess the quality of resilience and ability to resist cold flow so that the joint will remain sealed and tight when subjected to shock, vibration, pulsation and temperature or other adjustments of the pipeline.
- F. The couplings shall be assembled on the job in a manner to insure tight joints under all reasonable conditions of expansion, contraction, shifting and settlement, unavoidable variations in trench gradient, etc. The coupling shall be Dresser, Style 38, as manufactured by Dresser Manufacturing Division, Bradford, Penna., or approved equal.
- G. Wall seals shall be provided at all penetrations in concrete structures. In addition:
  - 1. The Contractor shall determine the required inside diameter of each individual wall opening or sleeve before ordering, fabricating or installing. The inside diameter of each wall opening shall be sized as recommended by the manufacturer to fit the pipe and seal to assure a water-tight joint.
  - 2. Seals shall be Link-Seal, as manufactured by Thunder line Corporation, or approved equal.

### **Acceptance Testing**

- A. Prior to acceptance, all new pressure pipes shall be tested as specified herein. The contractor shall be responsible for furnishing all labor, tools, equipment, materials, including water, pumps, compressors, pressure gauges, meters, and stopwatch subject to the approval of the Town.
- B. Any defective work, which shows up while conducting tests or before acceptance, shall be replaced or repaired by the Developer at his own cost and expense. Any leaks due to either blown joints or cracked pipe or fittings, shall be repaired by the Developer at his own expense

- C. All new force mains shall undergo a hydrostatic pressure test prior to acceptance by the Town of Middletown.
- D. Test Restrictions:
  - 1. All tests shall be conducted in the presence of a Town Inspector.
  - 2. Testing of all pressure pipes shall be conducted in accordance with AWWA C600 testing requirements.
  - 3. Test pressure shall be 150 psi.
  - 4. The hydrostatic pressure test shall be of at least a 2-hour duration.
  - 5. Valves shall not be operated in either direction at a differential pressure exceeding the rated valve working pressure. The test pressure shall not exceed the rated pressure of the valves when the pressure boundary of the test section includes closed, resilient-seated gate valves or butterfly valves.
- E. Pressurization
  - 1. After the pipe has been laid, all newly laid pipe or any valved section thereof, shall be subjected to a hydrostatic pressure of 150 psi. Each valved section of pipe shall be slowly filled with water, and the specified test pressure (based on the elevation of the highest point of the line or section under test and corrected to the elevation of the test gauge) shall be applied by means of a pump connected to the pipe. Valves shall not be operated in either the opening or closing direction at differential pressures above the rated pressure. It is good practice to allow the system to stabilize at the test pressure before conducting the test.
  - 2. Before applying the specified test pressure, air shall be expelled completely from the section of piping under test. If permanent air vents are not located at all high points, corporation cocks shall be installed at such points so that the air can be expelled as the line is filled with water. After all the air has been expelled, the corporation cocks shall be closed and the test pressure applied. At the conclusion of the pressure test, the corporation cocks shall be removed and plugged or left in place as directed by the Town.
  - 3. All exposed pipe, fittings, valves, and joints shall be examined carefully during the test. Any damage or defective pipe, fittings, valves, or joints that are discovered following the pressure test shall be repaired or replaced with sound material, and the test shall be repeated until satisfactory results are obtained.
- F. No drop in pressure will be allowed for the minimum two (2) hour duration. The Contractor shall be responsible to repair all defects in the event the pipe is unable to maintain pressure.

### **Construction Methods**

- A. The construction methods for sanitary sewer force mains shall be as described in the specifications outlined in the section entitled "Sanitary Sewer Gravity Mains and House Connections".



## **Alignment/Separation**

- A. The alignment and separation requirements for sanitary sewer force mains shall be as described in the specifications outlined in the section entitled “Sanitary Sewer Gravity Mains and House Connections”.

## **As-Builts Drawings**

- A. Upon completion of all sanitary sewer force mains, and prior to acceptance, as-built drawings shall be submitted to the Town of Middletown for review and approval. One electronic copy in .pdf format shall be submitted bearing the signature and seal of a Delaware registered surveyor or engineer with the same scale as the original approved drawings.

## **SANITARY SEWER MANHOLES AND MISCELLANEOUS STRUCTURES**

### **Description**

- A. The work described in this section involves sanitary sewer manholes and miscellaneous structures of concrete or brick masonry built to the shapes and dimensions in accordance with these Specifications and Details as shown in the Standard Details, at the location indicated on the Plans or as directed by the Town.

### **Material**

- A. Precast Manholes. Precast reinforced concrete risers, eccentric cones and bases shall be as detailed on the drawings and in conformance with ASTM Designation C 478. Joints between riser sections shall be fitted with an “O” ring rubber gasket, meeting the requirements of ASTM Designation C 443.

All pipe to manhole connections shall be made by means of an integrally cast flexible connector ~~which shall be Lock joint flexible manhole sleeve as manufactured by Interpace Corp., Parsippany, New Jersey, or A Lok flexible manhole gasket as manufactured by A Lok Corp., Trenton, New Jersey, or approved equal.~~

- B. Manhole Steps. Manhole steps shall be made of 3/8-inch diameter (No. 3) steel reinforcing bars, ASTM Designation A 615, Grade 60, encased in polypropylene plastic. Manhole steps shall have notched tread ridge with retainer lug on each side. Steps shall be spaced vertically and aligned as shown on the Standard Detail Drawing and set to provide a minimum of 6-inch tread. Manhole steps shall be OSHA approved ~~and as manufactured by M.A. Industries, Inc., Peachtree City, Georgia, ICM Inc., Jacksonville, Arkansas, or equal.~~
- C. Manhole Frames and Covers. Manhole frames and covers shall be furnished and set by the Contractor as the work progresses as shown in the Standard Detail Drawing. Frames shall be well bedded in a concrete collar. Material for frames and covers shall be in accordance with the Standard Specifications for gray iron castings ASTM Designation A 48 for Class No. 35. The manhole frame and cover shall be as shown in the Standard Details, or approved equal.

1. The cover shall have written on it "Town of Middletown Sanitary Sewer."
  2. The manhole frame and cover shall be as shown in the Standard Detail Section.
- D. The flow pipe channel through manholes shall be made to conform in shape and slope to that of the sewers. The top of the brick channel shall be at the same elevation as the crown of the main sewer line in the manhole. The channel shall drop a minimum of 1 inch from influent pipe to the effluent pipe.
- E. All concrete for manhole base slabs and cradles, flow channels, encasements, blocking, etc. shall have a minimum compressive strength of 3,000 psi at 28 days. Type II Portland Cement shall be used. All mortar and cement shall be non-shrink.
- F. All new laterals tying into existing concrete manholes shall require the manhole to be core drilled for the connection. The lateral shall be installed and a watertight seal accomplished with the use of Link Seal wall seals, or approved equal.

### Construction Methods

- A. Precast Manholes – Sanitary sewer manhole base and riser sections shall be ~~as manufactured by Atlantic Concrete Products Company, Virginia Precast Corporation, or approved equal.~~ [precast reinforced concrete and shall be supplied by a manufacturer approved by the Town.]
- B. Manholes installed within the sewer distribution system shall conform to the requirements of ~~New Castle County or~~ the Town of Middletown, ~~whichever is greater,~~ Type A-2 or A-3 precast manhole specifications.
- C. In addition to the gasket material used within the joints between sections of the manhole, an external joint wrap is required. The wrap is to be applied to a clean/dry surface and placed with the manhole joint centered within the membrane strip with a minimum overlap distance of eighteen (18) inches when wrapped around manhole. Wrap shall be a self-adhered membrane consisting of two waterproofing materials with an aggressive rubberized asphalt adhesive backed by a layer of high density cross laminated polyethylene or approved equal. The membrane strips shall be a minimum of ~~twelve (12)~~[nine (9)] inches wide.
- D. Lifting holes in the walls of precast reinforced concrete risers will be allowed but shall be plugged with rubber stoppers and grouted flush with face or manhole wall after installation of manhole riser sections. Not more than two holes shall be cast in the walls of each riser section for the purpose of handling.
- E. The exterior surface of all precast manholes shall receive a minimum two coat application of a 68 percent solids coal tar type protective coating. The total average dry film thickness shall measure 24 mils with no single measurement to be less than 20 mils. Surfaces shall be prepared in accordance with the manufacturer's instructions and coatings applied in the field in a manner

acceptable to the Town. The coating material shall be Bitumastic Super Service Black manufactured by Koppers Co., Inc., Pittsburgh, Pennsylvania, Tar-Jet Super Black XX-32-B-22 manufactured by Pennsbury Coatings Corp., New Britain, Pennsylvania, or approved equal.

F. ~~Channels for receiving and passing water shall be formed in the bottom of manholes as shown or directed. All such channels shall be lined with brick or split pipe. Channels shall slope smoothly and evenly from the main pipe entering the manhole to the outlet pipe. Brick channels for future extensions shall be built into manholes where shown on the Plans or where directed by the Developer's Engineer. Rubber gaskets approved by the Town shall be used to seal the pipe at all connections to the manholes.~~

G. Channels for receiving and passing water shall be formed in the bottom of manholes as shown in the Standard Details or as directed by the Town. All such channels shall be [factory] formed with concrete or lined with brick. [Concrete channels poured in the field will not be permitted.] Channels shall slope smoothly and evenly from the main pipe entering the manhole to the outlet pipe. Brick channels for future extensions shall be built into manholes where shown on the Plans or where directed by the Town. Rubber gaskets approved by the Town shall be used to seal the pipe at all connections to the manholes.

H.[G.] Manholes shall be installed as pipe laying progresses. The Town may stop the Contractor's work entirely on laying pipe until the manhole just passed has been completed.

### Location

A. Manholes shall be installed at the end of each sewer line; at all changes in grade, size, or alignment; at all intersections; and at distances not greater than 300 feet ~~for sewers 15 inches or less, and 400 feet for sewers 18 inches to 30 inches.~~ Manholes should not be located in the flow line of streets, within swales, nor within areas which may be subject to ponding conditions including low points which may periodically pond due to clogged stormwater inlets or other structures.

### Drops

A. A drop pipe should be provided for a sewer entering a manhole at an elevation of 24 inches or more above the manhole invert. Where the difference in elevation between the incoming sewer and the manhole invert is less than 24 inches, the invert should be filleted to prevent the buildup of solids. Refer to Standard Details.

### Minimum Diameter

A. The minimum diameter of [public] manholes [(those owned and maintained by the Town)] shall be 48 [60] inches. A minimum access diameter of 24 inches shall be provided.

[B. Private manholes may have a minimum diameter 48 inches.]

## Acceptance Testing

- A. A vacuum test shall be performed on each manhole to assure water-tightness in accordance with [ASTM C 1244-05a and] the following procedures.
1. Each manhole shall pass ~~two tests; the first test shall be after assembly but prior to backfilling and the second test shall be~~ [a vacuum test to be conducted] after backfilling is complete.
  2. The vacuum test shall include testing of the seal between the cast iron frame and the concrete cone, slab or grade rings.
  3. Plug all pipes entering the manhole at least 8 inches into sewer pipe. The plug shall be inflated at a location past the manhole/pipe gasket.
  4. Brace all plugs to prevent the plug or pipe from being dislodged and drawn into manhole.
  5. A vacuum of at least 10-1/2 inches of mercury shall be drawn on the manhole.
  6. The pressure gage shall be filled having a 3.5-inch diameter face with a reading from 0 to 30 inches of mercury. The test equipment shall be capable of having 2 gages connected. The gage supplied with the test equipment shall match the reading of a gage furnished by the Town of Middletown Sewer Department. The gage reading is to be verified on each project.
  7. The time elapsed for the vacuum reading to drop from 10 inches of mercury to 9 inches of mercury must not be less than the following times for manhole to be considered as passing the vacuum test:

<u>Manhole Depth</u>	<u>Time (minutes)</u>
10 feet or less	2.0
10.1 to 15 feet	2.5
15.1 to 25 feet	3.0

**TABLE 1: Minimum Test Times for Various Manhole Diameters in Seconds**

Manhole Depth (ft)	Manhole Diameter (in)		
	48	60	72
	Time (seconds)		
<4	10	13	16
6	15	20	25
8	20	26	33
10	25	33	41
12	30	39	49
14	35	46	57
16	40	52	67
18	45	59	73
20	50	65	81
22	55	72	89
24	59	78	97
26	64	85	105
28	69	91	113

8. If the manhole fails the vacuum test, the manhole shall be uncovered and patched on the exterior of the manhole and retested in accordance with the above specifications.

### **LIFT STATIONS/PUMP STATIONS**

#### **Description**

- A. Sanitary sewer lift stations/pump stations shall be designed and constructed in accordance with the Town of Middletown specifications and the “Town of Middletown Supplemental Lift Station/Pump Station Specifications”.

## **CHAPTER 46-3**

### **WATER**

## **PURPOSE**

The purpose of this article is to outline the requirements for the construction of water mains, water services, associated appurtenances and all other miscellaneous accessories within the Town of Middletown.

## **WATER MAINS AND APPURTENANCES**

### **Description**

- A. This section shall consist of installing new water mains, including tapping sleeves and valves, hydrants, fittings, concrete buttresses, and all other miscellaneous accessories as shown on the Plans and in accordance with these Specifications and Standard Details.

### **General Requirements**

- A. All water main pipe shall be ductile iron pipe (DIP).
- B. Minimum cover over all water mains and services shall be forty-two (42) inches.
- C. No water main shall be placed in the same trench with sanitary sewer, non-potable water, or gas.
- D. Separation of utilities shall be in accordance with Ten States Standards.
- E. The distribution system should be designed to promote loops and avoid dead ends due to water quality issues. When dead ends cannot be avoided, a flushing hydrant shall be installed on the dead end so the line can be flushed. Blow-offs are only permitted on a temporary basis. A standard fire hydrant may be used in place of a flushing hydrant if installed in accordance with the State of Delaware Fire Marshal Regulations.
- F. All tees, bends, caps, plugs, hydrants or other fittings that change the direction of flow shall be buttressed or anchored to prevent pipe movement caused by surges, water hammer or unbalanced pressure which could result in a water main break.
- G. Concrete for water main buttresses shall be 3,000 psi, ready-mix concrete using Type II Portland Cement. Site-mix, or bag-mixed concrete will not be allowed without approval from the Town of Middletown.
- H. Minimum size of water mains shall be six (6) inches. Water main sizes shall be comply with all requirements of the Delaware State Fire Marshal Regulations.

### **Materials**

- A. Ductile iron pipe (DIP) used for water mains shall be manufactured in accordance with ANSI/AWWA C151/A21.51, latest edition, and shall be a minimum of Class ~~52~~[50].

1. The pipe shall be double cement mortar lined with seal coat. Pipe intended for buried installation shall receive an external standard bituminous foundry coating in accordance with ANSI/AWWA C104/A21.4.
2. Pipe installed above ground shall be installed by means of flanged fittings in accordance with ANSI A21.10.
3. Buried ductile iron pipe shall be installed using push-on joints such as "Tyton" joints or mechanical joint pipe as manufactured by US Pipe and Foundry or approved equal. Rubber gaskets shall conform to C111 and ANSI A21.11 for mechanical and push-on joints.

### **Fittings**

- A. All fittings used to connect water main pipe shall be of the same material as the water main. Ductile iron fittings shall be manufactured in accordance with ANSI A21.10 and have a pressure rating of 250 psi. Fittings shall be provided with mechanical joint ends furnished in accordance with ANSI A21.11 except where noted on the plans.
- B. Inside of fittings shall be double cement lined with a bituminous seal coat in accordance with ANSI A21.4. Outside of fittings shall also be bituminous coated.

### **Gate Valves**

- A. Gate valves installed in the distribution system shall be resilient wedge type, ~~manufactured by Waterous, or approved equal.~~ Gate valves shall be installed in accordance with manufacturers specifications and standard installation practices as defined by AWWA for the application.
- B. The body shall be ductile iron and epoxy coated inside and out.
- C. Operation of the valve shall be by two (2) inch square nut and shall open by turning counterclockwise. Valves shall be furnished with mechanical joint ends.

### **Valve Boxes**

- A. Valve boxes shall be cast iron, 3-piece screw type installed over the valve bonnet and operating nut. Valve boxes shall be capable of being adjusted to reach the surface of the existing or proposed ground surface, but shall not extend above the finished grade at any time. If necessary, the water main depth shall be adjusted to allow for the proper installation of the valve box.
- B. Lids shall be extra deep with two (2) holes and the words WATER cast in the upper surface. ~~[Lids shall be ADA Compliant.]~~

### **Fire Hydrants**

- A. All ~~[public]~~ fire hydrants shall be Waterous WB 67, pacer type. ~~[Private fire hydrants can be any manufacturer as long as it meets NFPA.]~~



- B. Hydrants shall conform to AWWA C502, latest edition. The hydrant shall be required to have a means of lubricating the operating threads without disassembly. The hydrant seat shall be provided with bronze connections, a 5-1/4" main valve opening left, one 1-1/2" operating nut, one 4-1/2" pumper nozzle, two 2-1/2" hose nozzles with National Standard Threads and a six (6) inch mechanical joint inlet.
- C. Drain mechanisms shall be bronze to preclude galvanic corrosion of dissimilar metals and shall operate automatically with the opening and closing of the main valve.
- D. Hydrants shall be 4'6" in length and a bury depth of four (4) feet.
- E. The operating nut shall be six (6) sided and sized per local fire department requirements.
- F. Threads of all nozzles shall be National Standard threads.
- G. The smallest size main a hydrant can be connected to shall be six (6) inches in accordance with the Delaware State Fire Marshal Regulations.
- H. Non-kinking hose nozzle chains shall be provided.
- I. Hydrants installed in the Town of Middletown shall be yellow in color. They shall receive prime and shop coats of paint at the factory. The Contractor shall be responsible for field touch up or repainting of hydrants as required.
- J. The entire hydrant assembly, including the valve seat and all moving parts, shall be removable from the top without the need to excavate and/or remove the hydrant.
- K. Installed hydrants shall open left and close right.

### **Pipe Placement**

- A. Pipe and fittings shall be carefully handled and lowered into the trench onto the pipe bedding material. No large rocks or other sharp objects shall be allowed in the trench.
- B. Special care shall be taken to ~~insure~~ [ensure] that the pipes are well bedded on a solid foundation, and any defects due to settlement shall be made good by the Contractor.
- C. At the close of each workday the end of the pipeline shall be tightly closed with an expansion type stopper or plug so that no dirt or other foreign substance may enter the line. This stopper or plug shall be kept in place until pipe installation is resumed.
- D. No pipe shall be installed upon a foundation into which frost has penetrated, nor at any time when the Town of Middletown deems that there is danger of the formation of ice or the penetration of frost at the bottom of the excavation; unless

all required precautions as to the minimum length of open trench and promptness of backfilling are observed.

- E. The ends of pipe shall abut against each other in such a manner that there shall be no shoulder or unevenness on the inside of the main.
- F. Water pipe shall be encased with 3,000-psi minimum concrete where indicated on the drawings. Ready-mix, Type II Portland Cement shall be used.

### Pipe Bells

- A. It is important that pipe bells do not have any undue weight placed on them. Bell holes shall be dug for each pipe bell to cradle the joints and evenly support the pipe. Gasket lubricant specified by the pipe manufacturer and approved for water service for proper pipe joint installation shall be used.

### Separation of Utilities

- A. In general, horizontal and vertical separation shall be per Ten States Standards. Water mains shall be laid at least ten (10) feet horizontally from any existing or proposed sewer main. The distance shall be measured edge to edge. Separation between sewer and water laterals shall be a minimum of three (3) feet measured outside edge to outside edge, or as required in the latest plumbing code adopted by the Town of Middletown, whichever is stricter.
- B. Water mains crossing sewer mains shall be laid to provide a minimum vertical distance of eighteen (18) inches between the outside of the water main and the outside of the sewer.
  - a. Water mains shall be located above sewer mains unless otherwise authorized by the Town of Middletown.
  - b. When a sewer main crosses an existing water main, the crossing shall be arranged so that the sewer joints will be equidistant and as far as possible from the water main joints.
  - c. Where a water main crosses under a sewer, adequate structural support shall be provided for the sewer to maintain line and grade and prevent damage to the water main.
  - d. When it is impossible to obtain proper horizontal and vertical separations stipulated above, the Town of Middletown may allow deviations on a case-by-case basis, if supported by data from the Design Engineer. Alternate design shall meet Ten States Standards.

### Pipe Detection

- A. Pipeline detectable tape shall be installed continuously along all water mains. The tape shall be installed directly above the water main and twelve (12) to eighteen (18) inches below the ground surface. ~~The tape shall be Lineguard Type III Detectable Tape as manufactured by Lineguard, Inc., of Wheaton, Illinois, or equal.~~ The tape shall be a minimum of two inches wide, blue in color, imprinted with the words “**Caution-Water Line Below**”, and be capable of being detected with inductive methods.

- B. Water mains shall have trace wire installed continuously along its length. Trace wire shall be installed in accordance with the Town of Middletown “Supplemental Trace Wire Specification.”

### **Construction Methods**

- A. All pipe and fittings shall be installed according to the applicable requirements of AWWA, the manufacturer’s guidelines, as specified herein, and as indicated in the Standard Details.
- B. Normal excavation will be considered from the outside pipe dimension plus eighteen (18) inches each side, unless otherwise designated on the plans.
- C. Unsuitable foundation material shall be removed below the normal designed elevation as directed by the Town of Middletown.
- D. When a pipe is to be placed either partially or completely in a fill, the embankment shall be compacted to an elevation of one (1) foot above the top of the proposed pipe installation for a minimum of thirty-six (36) inches on each side of the pipe.
- E. Trench or ditch bottoms containing bedrock, soft areas such as muck or refuse, or other material unable to provide long-term support to the pipe are unacceptable. Remove rock and other unyielding material one (1) foot below the pipe bottom and six (6) inches on either side of the pipe unless otherwise directed by the Town of Middletown. Excavate soft areas to a depth of two (2) feet below the pipe bottom and three times the width of the pipe unless otherwise directed by the Town of Middletown to excavate deeper or wider. If a firm foundation is exposed, replace the excavated material with acceptable backfill material and compact to 95 % Modified Proctor density.
- F. If the soft area remains after excavation, and if approved by the Town of Middletown, synthetic fabric (geotextile) shall be used to separate the native soil from the backfill. After the fabric has been laid on the native soil, replace the excavated material with acceptable backfill material and compact to 95 % Modified Proctor density.
- G. When rock, hardpan or other unyielding material is encountered, the trench shall be excavated as shown on the plans for bedding in rock, or as directed by the Town of Middletown in the absence of a detail, and shall be backfilled with materials meeting the requirements of this section.

### **Backfill and Compaction**

- A. All trench backfill shall be compacted. Backfill of pipe shall be compacted with equipment in a manner which is capable of producing the required results. Backfill material shall be placed and graded in uniform horizontal lifts, which may not exceed eight (8) inches. Compaction will not be performed by jetting or water settling. If during the compaction of the trench, any soft, yielding, or spongy areas are observed, backfilling operations will cease until stability of these areas is achieved. The Town of Middletown has the authority to request

field moisture/density control tests to document compliance of work as per DelDOT's specifications. Failed areas shall be compacted again and retested. A Geotechnical Consultant approved by the Town of Middletown shall perform moisture/density tests at the expense of the Owner/Developer.

- B. Water main [pipe bedding] shall be placed on a minimum six (6) inch bedding of #57 stone [per standard detail W-3].
- C. Where the pipes are under the roadway pavement or shoulders, the backfill material shall be compacted in a maximum of eight (8) inch lifts to 95% of the Modified Proctor density.
- D. Where pipes are not under the roadway pavement or shoulders, compaction shall be in a maximum of eight (8) inch lifts to 92% Modified Proctor density.

#### **Thrust Restraint – Concrete Buttress**

- A. Thrust restraints shall be used in all cases where there is a dead end, hydrant, valve, tee, or bend.
- B. The size and shape of concrete thrust blocks shall be as specified in the Standard Details.
- C. The length of restrained joint piping and details of joint restraint glands, rodding, clamps, friction slabs, or other anchors shall be as specified by the Town of Middletown.

#### **Tools**

- A. Proper and suitable tools and appliances for the safe and convenient handling and installation of pipes and fittings shall be used. Great care shall be taken to prevent the damage to the pipe, and bell and spigot ends. Any damaged pipe shall be replaced to the satisfaction of the Town.

#### **Cleaning**

- A. Pipe and fittings shall be thoroughly cleaned before they are laid and shall be kept clean until the acceptance of the completed work.

#### **Cutting**

- A. Whenever a pipe or fitting requires cutting, to fit into the line or to bring it to the required location, the work shall be done in a satisfactory manner to leave a smooth beveled end, and without extra compensation.

#### **Joining Pipe and Fittings**

- A. In joining pipe and fittings, the Contractor shall exercise particular care to insure that the outside of the spigot and inside of the bell is entirely free of oil, tar and greasy substances to insure a tight fit. All concrete required to construct buttresses behind plugs, tees, hydrants, bends and other fittings and anchorages

beneath vertical bends shall be placed in accordance with the Standard Details or as shown on the Plans.

### **Installation of Valves and Fittings**

- A. Install fittings and valves where indicated on the Plans, or as directed by the Town of Middletown. Where valves occur on the end of the pipeline, place a cast iron plug and secure in the exposed bell before backfilling the trench. Buttress the valve.
- B. A valve box shall be carefully placed over the bonnet of each gate valve with the top at the finished surface of the street sidewalk or at such other elevation, as the Town of Middletown shall direct. It shall be set plumb. In tamping the backfill around the box, special care shall be taken to keep the box plumb and to have it firmly supported to avoid settlement. Any box which is found out of plumb, or which is not firmly supported, shall be excavated and reset in a satisfactory manner.
- C. There shall be as many valves installed as there are pipes entering and leaving any pipe intersection, typically three valves at each tee, and four valves at each cross.
- D. Valve boxes shall be set in such a manner that the operating nut of the installed valve is set center in the valve box.
- E. All main line valves and hydrant valves installed in grass, asphalt or concrete shall have a 12" x 12" x 12" concrete collar measured from the outside edge of the valve box. The collar shall be installed to an elevation equal to the proposed final grade.
- F. Maximum valve spacing should not exceed eight hundred (800) feet.

### **Installation of Tapping Sleeve and Valves**

- A. Location of tapping sleeves and valves shall be as indicated on the Plans or as directed by the Town of Middletown. Installation shall be as per the manufacturer's recommendations.
- B. The Contractor shall notify the Town of Middletown at least 72 hours prior to tapping the water main. The Contractor shall install the tapping sleeve and valve in such a manner so as not to disrupt the existing water service.
- C. Tapping sleeves shall be rated for 150 psi working pressure minimum.

[D. Tapping sleeves are to be stainless steel.]

### **As-Builts Drawings**

- A. Upon completion of all water mains, and prior to acceptance, as-built drawings shall be submitted to the Town of Middletown for review and approval. One electronic copy in .pdf format shall be submitted bearing the signature and seal of

a Delaware registered surveyor or engineer with the same scale as the original approved drawings.

## **STERILIZATION OF WATER MAINS**

### **Description**

- A. This section shall consist of disinfecting all newly laid water mains, including valves, fittings, fire hydrants, and all other miscellaneous accessories which carry potable water for use for domestic consumption or fire suppression in accordance with these Specifications. The procedure to be used for disinfecting shall be in accordance with the latest edition of AWWA C601.

### **Flushing and Disinfection**

- A. All new sections of water main must be thoroughly flushed, disinfected and tested for bacteriological quality before the water main can be put in service.
- B. Flushing of the main shall be performed to remove any mud and debris left in the pipe from the installation. All flushing activity must be coordinated with the Town of Middletown.
- C. The Contractor shall disinfect the new water system by placing in each length of pipe, hydrant, hydrant branches and other appurtenances, a sufficient amount of calcium hypochlorite tablets to insure adequate disinfection. Tablets shall be fastened to the inside top of every length of pipe, hydrant and appurtenance, using a food grade adhesive or glue that is non-harmful to human consumption. All adhesives or glues used to secure tablets must be approved by the Town of Middletown prior to use.
- D. The Contractor shall be entirely responsible for achieving minimum residual chlorine content of five (5) ppm at the extremities of the water mains after twenty-four (24) hours or more contact with the full water pressure on the main.
- E. Water for filling the mains shall be introduced at a velocity of less than one (1) foot per second in order to permit the tablets to completely dissolve and have a reasonably uniform distribution throughout the mains. Introducing water to the main at this velocity will help keep the tablets from becoming dislodged and washed to the end of the system.
- F. Water for disinfection shall be furnished by the Contractor from a source approved by the Town of Middletown.
- G. The Contractor shall furnish and install all material, labor and equipment required to sterilize the pipe section.
- H. The chlorine solution should be maintained in the pipe a minimum of twenty-four (24) hours before a bacteriologic sample is taken.

### **Chlorine Residual**

- A. After the chlorine has been in contact with the mains for twenty-four (24) hours or longer, samples collected from the extremities of the mains shall indicate residual chlorine content of five (5) ppm or more.
- B. The Contractor will be held entirely responsible for securing a minimum residual chlorine content of five (5) ppm at the extremities of the mains after twenty-four (24) hours or more contact with the full water pressure on the main.
- C. If less than five (5) ppm residual chlorine is indicated, the system shall be drained, dechlorinated, and the disinfection treatment repeated.
- D. If samples collected at the extremities indicate a residual chlorine of five (5) ppm or more, the system shall be flushed until there is only a normal chlorine residual (1.0 ppm. or less) present, as determined by the DPD Method Test.

### **Bacteriological Testing**

- A. After a new pipe has been disinfected and flushed, it shall be refilled with water from the distribution system and tested for bacteriological quality.
- B. No pipe or pipe section shall be placed into service until after it has been tested.
- C. No samples shall be taken until after the pipe has been filled for twenty-four (24) hours with system water.
- D. The Contractor is responsible for furnishing all labor, equipment, and material necessary to take the required samples.
- E. Samples of water shall be collected from various points along the lines. The Contractor is responsible for having the samples tested by either the State Health Department or a laboratory approved by the Town of Middletown.
- F. No sample or other testing will be done without a Town of Middletown Inspector present on site to witness the sampling.
- G. If satisfactory bacteriological results are obtained, the lines may then be allowed to be placed in service. A copy of all test results shall be submitted to the Town of Middletown.
- H. If the test results are not satisfactory, the system shall be sampled again. If the results from the second sample are still positive for the presence of bacteria, the Contractor will be required to repeat the disinfection and bacteriological testing of the pipeline until the bacteriological testing is satisfactory.

## **PRESSURE AND LEAKAGE TESTING OF WATER MAINS**

### **Description**

- A. This item shall consist of simultaneous pressure and leakage testing all newly installed water mains, including valves, fittings, fire hydrants and all other miscellaneous accessories which carry potable water for use for domestic consumption or fire suppression in accordance with these Specifications.

### **Simultaneous Pressure and Leakage Testing**

- A. Prior to acceptance, all new pipes and appurtenances shall be tested as specified herein. The Contractor shall be responsible for furnishing all labor, tools, equipment, materials, including water, pumps, compressors, pressure gauges, meters, and stopwatch subject to the approval of the Town of Middletown.
- B. Any defective work, which shows up while conducting tests or before acceptance, shall be replaced or repaired by the Contractor at his own cost and expense. Any leaks due to either blown joints or cracked pipe or fittings, shall be repaired by the Contractor at his own expense.
- C. All new water mains and appurtenances shall undergo a simultaneous hydrostatic pressure and leakage test prior to acceptance by the Town of Middletown.
- D. Test Restrictions:
  - 1. All tests shall be conducted in the presence of a Town of Middletown Inspector.
  - 2. Testing of all pressure pipes shall be conducted in accordance with AWWA C600 testing requirements.
  - 3. Test pressure shall be 150 psi.
  - 4. The test duration shall be two (2) hours.
  - 5. Valves shall not be operated in either direction at a differential pressure exceeding the rated valve working pressure. The test pressure shall not exceed the rated pressure of the valves when the pressure boundary of the test section includes closed, resilient-seated gate valves or butterfly valves.
- E. Pressurization
  - 1. After the pipe has been laid, all newly laid pipe or any valved section thereof, including hydrants, shall be subjected to a hydrostatic pressure of 150 psi. Each valved section of pipe shall be slowly filled with water, and the specified test pressure (based on the elevation of the highest point of the line or section under test and corrected to the elevation of the test gauge) shall be applied by means of a pump connected to the pipe. Valves shall not be operated in either the opening or closing direction at differential pressures above the rated pressure. It is good practice to allow the system to stabilize at the test pressure before conducting the test.



2. Before applying the specified test pressure, air shall be expelled completely from the section of piping under test. If permanent air vents are not located at all high points, corporation cocks shall be installed at such points so that the air can be expelled as the line is filled with water. After all the air has been expelled, the corporation cocks shall be closed and the test pressure applied. At the conclusion of the pressure test, the corporation cocks shall be removed and plugged or left in place as directed by the Town of Middletown.
  3. All exposed pipe, fittings, valves, hydrants, and joints shall be examined carefully during the test. Any damage or defective pipe, fittings, valves, hydrants, or joints that are discovered following the pressure test shall be repaired or replaced by the Contractor with sound material, and the test shall be repeated until satisfactory results are obtained.
- F. The allowable leakage will be defined as the maximum quantity of water required to be supplied into the water main upon completion of the two (2) hour test to maintain the water pressure within five (5) psi of the specified test pressure after the pipe has been filled with water and air expelled. No pipe installation will be acceptable if the leakage is greater than the maximum allowable leakage as calculated by the Town of Middletown. The Contractor shall be responsible to repair all defects in the event the pipe is unable to maintain pressure.

## **HYDRANTS**

### **Description**

- A. This section shall consist of installing new fire hydrants and associated valves, fittings, concrete buttresses, and all other miscellaneous accessories as shown on the Plans and in accordance with these Specifications and Standard Details.

### **Location and Spacing**

- A. Fire hydrants shall be spaced no more than four hundred (400) feet apart as measured along curb lines.
- B. In commercial or business areas no part of a building or part thereof shall be more than 300 feet from a fire hydrant as measured in a straight line.
- C. Fire hydrants shall be located at intersections when practical but not more than the spacing as required above.
- D. Fire hydrants located at mid blocks shall be installed at property lines and located so they do not interfere with driveways.

### **Hydrant Installation**

- A. No fire hydrant shall be installed at a depth greater than four (4) feet regardless of location or depth of main.
- B. Hydrants shall be installed on a bed of crushed stone extending the full width of

the trench, covering the area beneath the shoe, and extending upward to a point six (6) inches above the drain rings in accordance with the Standard Details.

- C. Hydrants shall be strapped to the main and restrained with mechanical joint restraints (i.e. MegaLug, or approved equal).
- D. Hydrants shall be secured to the supply pipe by use of underground clamps and pipe retainers for the type of pipe installed.
- E. The hydrant shall be installed with the steamer outlet facing the street line unless otherwise directed by the Town of Middletown.
- F. Fire hydrants shall be set plumb and level at locations shown on the construction plans or as directed by the Town of Middletown.
- G. Hydrants shall be installed so there are twenty (20) inches of clearance as measured between the finished grade and the center of the operating nut on the steamer nozzle.
- H. Fire hydrants shall not be placed closer than 2'6" or more than seven (7) feet from the face of the curb or edge of pavement on streets without curb. Any other distance shall require approval from the Town of Middletown.
- I. If the main is considerably deeper at the hydrant location it shall be angled up to allow the installation of a four (4) feet buried hydrant in all cases.
- J. Hydrants shall be installed so that the breakaway flange is between 1-1/2 and 2-1/2 inches above finished grade.

## **WATER SERVICES**

### **Description**

- A. This section shall consist of installing new water services between the main line and the customer's property within the right-of-way using copper pipe, and associated fittings as shown on the Plans and in accordance with these Specifications and the Standard Details.
- B. Water service replacement of existing service shall be accomplished by boring, tunneling or jacking into place in lieu of open cutting unless the service is outside of a paved area. Water service replacement shall be coordinated with the Town of Middletown.

### **Materials**

- A. Water service pipes between the distribution main and the curb stop of the property shall be soft copper tubing, Type K in accordance with ASTM B-88, for water service lines up to one (1) inch diameter maximum. For water service lines greater than one (1) inch in diameter, pipe material shall be HDPE CTS.]

- B. All fittings used to connect service lines shall be compression type fittings manufactured by Mueller or approved equal unless specifically listed otherwise in this section.
- C. Corporation stops shall not be less than 3/4 inch with AWWA standard inlet threads, suitable for connection to K-copper service piping as specified herein. Stops shall be ground key design with ~~copper flare (Model H-15000)~~ [compression connection (Model H-15008N)] for CTS O.D. tubing as manufactured by Mueller, or approved equal.
- D. [Where required and approved by the Town,] Saddles shall have a bronze body, double stainless-steel straps with AWWA taper threads Mueller part number BR-2-S or approved equal.
- E. Curb stops are to be of brass construction, closed-bottom body. The top shall be configured to allow the attachment of a stationary rod to allow the valve to be turned off or on without the use of curb box key.
  - 1. The curb stop shall be by Mueller ~~Mark II Oriseal H-15204 or H-15174~~ [300 Ball Curb Valve with Mueller 110 Connection Model B-25209N] as shown on the Standard Details or approved equal.
  - 2. The stationary rod shall be of sufficient height so that it is not less than six (6) inches from the top of the installed curb box to allow the curb stop to be shut off or turned on without the use of a valve key.
  - 3. The stationary rod shall be compatible with the curb stop and manufactured by Mueller or approved equal.
- F. The curb box shall be cast iron, arch pattern compatible with the curb stop and be manufactured by Mueller or approved equal as shown on the Standard Details.
- G. The curb box lid shall be cast iron with standard pentagon bolt as manufactured by Mueller or approved equal.

### **Construction Methods**

- A. Before installation, pipe shall be carefully inspected for cuts, punctures, and excessive abrasion. Damaged areas shall be cut out and the pipe re-coupled to form a continuous length.
- B. Care shall be taken during hot weather installation to ~~insure~~ [ensure] that pipe has contracted to normal length before trench backfilling commences.
- C. Pipe, curb boxes and fittings shall be carefully handled in and out of the trench. Special care shall be taken to ~~insure~~ [ensure] that pipe is well bedded on a solid foundation and any defects due to settlement shall be corrected by the Contractor.
- D. Proper and suitable tools and appliances for the installation of pipe fittings shall be used. Pipe damaged in any way shall be replaced by the Contractor.
- E. Pipe and fittings shall be thoroughly cleaned before they are installed and shall be kept clean until acceptance of the completed work.

- F. Whenever pipe or fittings require cutting to fit in the line or to bring it to required location, the work shall be done in a satisfactory manner to leave a smooth end.
- G. Corporation stops shall be spaced a minimum of twenty-four (24) inches apart along the barrel of the main.
  - 1. Corporation stops should be located at least two (2) feet from the pipe ends. If two insertions are made, one on each side of the main, they should be separated (measured along the pipe length) by at least two (2) feet. Multiple insertions made on the same side of the main should be staggered 30 degrees around the circumference as well and separated by at least two (2) feet.
  - 2. Corporation stops installed in new or existing ductile iron pipe shall be with an approved tapping machine.
- H. Valves, fittings and curb boxes shall be placed and installed in accordance with the manufacturer's recommendations.
- I. The curb stop shall be located in accordance with the Plans, or as directed by the Town of Middletown.
- J. No couplings are allowed between the corporation stop and the curb stop. Couplings to connect terminal ends of copper tube shall be Mueller [H-15403N three] H-15405 two-part union, or approved equal.
- K. Sweat joints are not permitted in the Town of Middletown.
- L. Individual service lines (laterals) shall be made at a 45-degree angle down from the top of the main. The service line shall be laid in a "S" curve down from the tap so there is plenty of slack to allow for earth settlement and pipe expansion and contraction.
- M. The service line shall have a minimum of forty-two (42) inches of cover.

**Pressure Testing of the Water Service**

- A. After installation of the water service pipe and appurtenances has been completed, but prior to backfilling of the trench and connecting to the house, each water service line shall be flushed out for a minimum of three (3) minutes. The Contractor shall be responsible for disposal of the flushed water.
- B. The pipe shall then be plugged at the house and the corporation stop reopened to fill and pressurize the service line. The line shall be kept at the Town of Middletown residual water pressure for a period of two (2) hours.
- C. Should the test show any leakage of the service pipe, corporation stop, curb stop or fittings, the Contractor shall immediately remedy the defects causing the leakage. The pressure test shall be repeated until the service pipe and appurtenances withstand the Town of Middletown pressure for a full two (2) hour period.

## **METERS**

### **Description**

- A. This section shall consist of installing water meters, fittings, and all other miscellaneous accessories as shown on the Plans and in accordance with these Specifications and Standard Details.

### **Meter Supply**

- A. Every home, apartment, store, business or place where people work, live or have water connected to the premises shall be metered for water use.
- B. All meters, vaults, fittings and miscellaneous accessories installed within the Town of Middletown's water service territory shall be purchased by the Owner/Developer from the Town of Middletown. [For meters up to 2",] [t]he purchase includes all required remote water meter reading devices. [For meters greater than 2", only the meter is supplied by the Town.]

### **Meter Installation**

- A. The meter shall be installed in a location approved by the Town of Middletown. The Town of Middletown may require[s] the meter to be located outside in a meter pit or meter vault with suitable means of access.

### **Shutoff Valves**

- A. All meters, regardless of location, shall have two valves installed, one upstream and the other downstream on each meter installed at that location. The upstream valve must be a ball type valve and the downstream valve may be a ball valve.

### **Meter Pits/Vaults and Meters**

- A. Meter pits and vaults in residential districts shall only be permitted upon written approval from the Town of Middletown. Meter pits and vaults are required in commercial and industrial districts unless written approval is given by the Town of Middletown to allow the installation of the meter inside the building. The Owner/Developer shall be required to purchase all pits and vaults in accordance with these Specifications and Standard Details.

### **Meter Service for Apartments/Condominiums**

- A. The metering of apartments and condominiums shall be reviewed with the Town of Middletown Meter Department and Water Department prior to construction.

### **Meter Capacity**

- A. The capacity of the meter shall be consistent with the customer's water needs as determined by the Owner/Developer.

## **BACKFLOW PREVENTERS**

### **Description**

- A. This item shall consist of installing backflow preventers in the water distribution system between the Town of Middletown water mains and water service to private property to prevent contamination of the Town of Middletown's water system in accordance with these Specifications and the Standard Details and as shown on the Plans.

### **Installation**

- A. Backflow preventers shall be installed ~~inside~~ [outside] the building in accordance with the latest plumbing code adopted by the Town of Middletown, or as required by the State of Delaware. Any backflow prevention ~~outside~~ [proposed inside] of the building will be reviewed and approved by the Town of Middletown on a site-specific basis. All cost associated with the purchase and installation of backflow preventers shall be the responsibility of the Owner/Developer.

**CHAPTER 46-4**  
**OPEN SPACE/RECREATION**

## **INTENT**

The intent of this article is to outline the requirements for the construction of public open space and recreation equipment intended to be dedicated to the Town of Middletown.

## **OPEN SPACE**

### **Description**

- A. Open space, both passive and active, intending to be dedicated to the Town of Middletown shall be constructed in accordance with the approved plans.

### **General Open Space Requirements**

- A. A minimum of six (6) inches of graded topsoil shall placed or retained on all open space, seeded with a mixture of 80 percent ["turf" type] tall fescue and 20 percent rye. [The use of K31 seed mix will not be permitted.] The seed shall be required to attain a germination rate of 95 percent for acceptance by the Town of Middletown. The Developer shall provide the Town of Middletown with proof of the seed mixture prior to placement. Amendments to the prescribed seed mixture will only be allowed with permission from the Town of Middletown.
- B. Topsoil must be free of trash, rocks, concrete, blacktop, tree roots and weeds prior to the placement of final seed.
- C. Berms shall be designed and graded to not exceed a slope of 4:1.
- D. Silt fence shall be completely removed, not cut off at ground level. All disturbed area in the vicinity of the silt fence shall be graded and seeded in accordance with these specifications prior to final acceptance by the Town of Middletown.
- E. Open space shall be maintained by the Developer until final acceptance by the Town of Middletown. During this time period, the grass shall be maintained to a maximum height of six (6) inches.
- F. Trees and shrubs shall be planted a minimum of ten (10) feet off property lines. The minimum separation between each tree and shrub shall be ten (10) feet. The minimum separation between trees and shrubs can be reduced if they are part of a singular landscaped bed or island.

### **Seeding Preparation**

- A. Prior to seeding, the Town of Middletown shall examine finish surfaces, grades, topsoil quality and depth. Seeding shall not start until unsatisfactory conditions are corrected.



- B. Limit preparation to areas which will be immediately seeded.
- C. Remove existing temporary lawn and other vegetation and dispose of such material outside of the open space. Do not turn existing vegetation over into soil being prepared for permanent lawn. "Round - Up" shall be sprayed a minimum of two weeks prior to preparation to avoid removal of vegetation and topsoil loss. Incorporate organic residue into top six (6) inches of soil. Bring soil to finished grade to provide positive drainage as shown on the plans.
- D. Loosen topsoil of lawn area to minimum depth of 6". Remove stones over 1" in dimension and sticks, roots, rubbish and extraneous matter.
- E. Grade lawn areas to a smooth, free draining even surface with a loose, moderate course texture. Roll, rake and remove ridges and fill depressions as required to drain.
- F. Apply limestone at the rate determined by soils test to adjust pH of topsoil to not less than 6.0 or more than 6.8.
- G. Apply fertilizer at a rate determined by soils test and as directed by the Town. Fertilizer shall be thoroughly and evenly incorporated with soil to a depth of 6" by disking or other approved method. Fertilize areas inaccessible to power equipment with hand tools and incorporate into soil.
- H. Restore prepared areas to specified condition if eroded settled or otherwise disturbed after fine grading and prior to seeding.

### **Seeding**

- A. Lawn Seed immediately after preparation of bed. Spring seeding shall occur between April 1 and May 1; Fall seeding shall occur between August 15 and October 15, or at such other times acceptable to the Town.
- B. Seed indicated areas within open space limits and areas adjoining open space limits disturbed as a result of construction operations.
- C. Perform seeding operations when the soil is dry and when winds do not exceed 5 miles per hour.
- D. Apply seed with approved hydroseeder, billion drill, or hurricane seeder.
- E. Sow seed at a rate of 8.0 lbs. per 1,000 sq. ft. (348 lbs./acre).

- F. Raking & rolling – after sowing seed, rake the area lightly and roll with a 200 lb. hand roller. The finished grade of the seeded area must present an even, smooth and finished appearance.

### **Mulching**

- A. Straw Mulch: straw shall be spread over all seeded areas at the rate of 2.50 tons per acre. Mulch shall be applied to a uniform loose depth of not less than 1" and no more than 2". Mulch applied shall achieve a uniform distribution and depth so that no more than 10% of soil surface is exposed. Secure with a mulch anchoring tool. Punch, crimp and anchor mulch into the soil surface a minimum of 2".

### **Maintenance**

- A. Developer shall maintain seeded lawns until final acceptance of the open space from the Town of Middletown.
- B. Water to maintain adequate surface soil moisture for proper seed germination. Water daily to keep surface consistently moist.
- C. Repair, rework, and re-seed all areas that have washed out, are eroded or do not “catch”.
- D. Mow lawn areas as soon as lawn top growth reaches a 3" height. Cut back to 2" in height. Repeat mowing as required to maintain specified height.

### **Acceptance**

- A. Seeded open space areas will be inspected at completion of installation and accepted subject to compliance with specified materials and installation requirements.
- B. Seeded areas for open space will be acceptable provided all requirements, including maintenance, have been complied with and a healthy, uniform close stand of the specified grass is established free of weeds, undesirable grass species, disease and insects.
- C. No areas shall have bare spots or unacceptable cover totaling more than 5% of the individual areas, in areas requested to be inspected. A 95% coverage is required.
- D. The Town of Middletown will assume all maintenance responsibilities upon final acceptance.

## **Walking Trails**

- A. Walking trails shall be constructed of asphalt. The trail shall be constructed to the width specified on the approved plans.
- B. Walking trails shall be constructed with a minimum of two (2) inches Type “C” asphalt on a minimum of six (6) inches graded aggregate base course. A proof roll of the aggregate, performed in the presence of the Town, shall occur and pass prior to the placement of the asphalt. The asphalt shall be laid by machine in accordance with DelDOT specifications. The Contractor shall review the intended method of construction with the Town prior to placing the asphalt.
- C. Topsoil must be graded level to the walking trail and seeded.

## **Playground Equipment**

- A. All playground equipment shall be manufactured by Miracle Equipment, or approved equal.
- B. A sign signifying the appropriate age group shall be installed.
- C. Playground must be handicapped accessible (ramps and entrances).
- D. Concrete sidewalk leading to playground equipment must be six (6) feet wide, four (4) inches thick, installed on a minimum of four (4) inches of graded aggregate base course.
- E. Playground equipment shall be installed by certified installer. Proof of certification shall be provided to the Town of Middletown.
- F. Playground border must be made of plastic, not wood, and installed above ground, not buried.
- G. The playground equipment shall be installed on level and well-drained land.
- H. Trash receptacles shall be manufactured by Miracle Equipment, Model No. 5936 (36-gallon, black), or approved equal.
- I. Playgrounds must be posted with the following signs in accordance with DelDOT and Town of Middletown specifications:
  - 1. No alcohol or drugs
  - 2. Park closed dusk to dawn
  - 3. Children must be supervised by an adult at all times

## **SUPPLEMENTAL TRACER WIRE SPECIFICATION**

## **Supplemental Trace Wire Specification**

### **GENERAL**

This Construction Standard governs trace wire installation on water and sewer mains. Trace wire shall be installed on all mains.

### **TRACE WIRE MATERIAL**

Trace wire to be twelve (12) gauge minimum stranded copper with thermoplastic insulation recommended for direct burial. Wire connector shall be watertight and provide electrical continuity.

### **TRACE WIRE CONNECTIONS**

Connections into existing trace wire, connections into trace wire used during water main bores, connections between one spool of trace wire to another, and other similar connections shall be made using a SnakeBite Connector, as manufactured by Copperhead Industries, LLC, or approved equal. When connecting trace wire ends together, the connection should be made in accordance with the manufacturer's recommendations.

Connections of trace wire at tees, crosses, and at locations where the trace wire will be brought to the surface shall be conducted using a direct bury lug. Refer to Figure 1 for this connection style.

### **INSTALLATION**

Trace wire shall be installed in a continuous fashion. Install trace wire on top of main and secure to main every ten (10) feet with duct tape. Bring trace wire to surface at every cc box, vault, cathodic protection test station, and dead end hydrants. Trace wire shall be brought to the surface at least every one thousand (1000) feet. Take care not to damage the wire coating. Repair damaged coating with electric tape.

Trace wire shall be brought up in all vaults. Trace wire shall be brought to the surface according to Figure 2. Do not wrap the trace wire around the steps or any other place where a person entering the vault could trip on the wire.

Trace wire in cathodic protection test station shall be installed according to the manufacturer's specifications. Connect the trace wire to the brass connecting screws as shown in Figure 3.

Trace wire shall be brought up in all cc boxes. Trace wire shall be brought to surface according to Figure 4.

Trace wire shall be brought up in a PVC conduit at all dead end/end of main fire hydrants without a valve and at hydrants of a non-typical branch (i.e. dog-legged hydrant branch). Trace wire shall be brought to the surface according to Figure 5.

**TESTING**

Contractor shall perform a continuity test on all trace wire in the presence of a Town of Middletown Inspector.

<b>REVISED</b>	<b>09/06/2012</b>

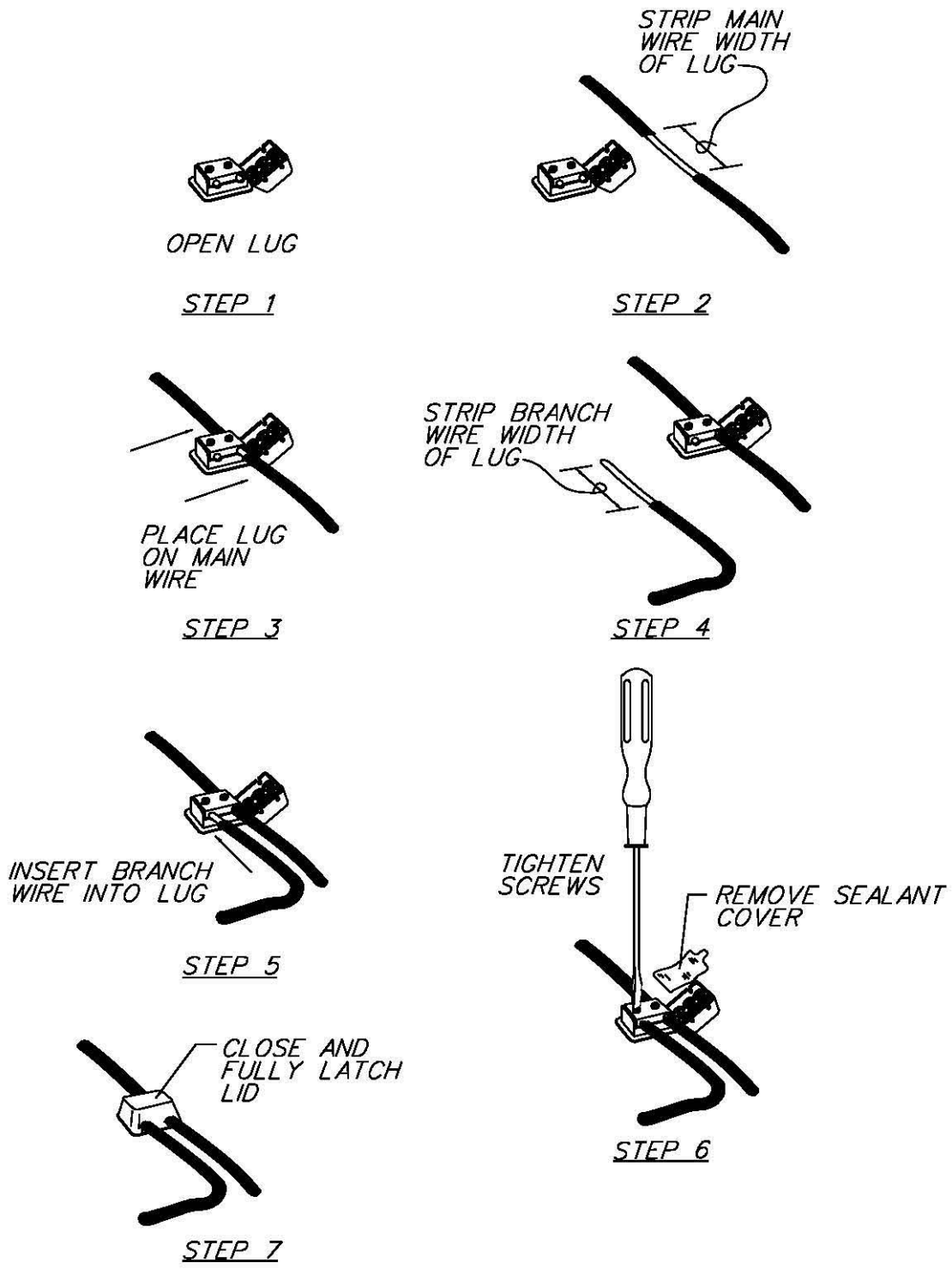

Figure 1. Direct bury lug connection

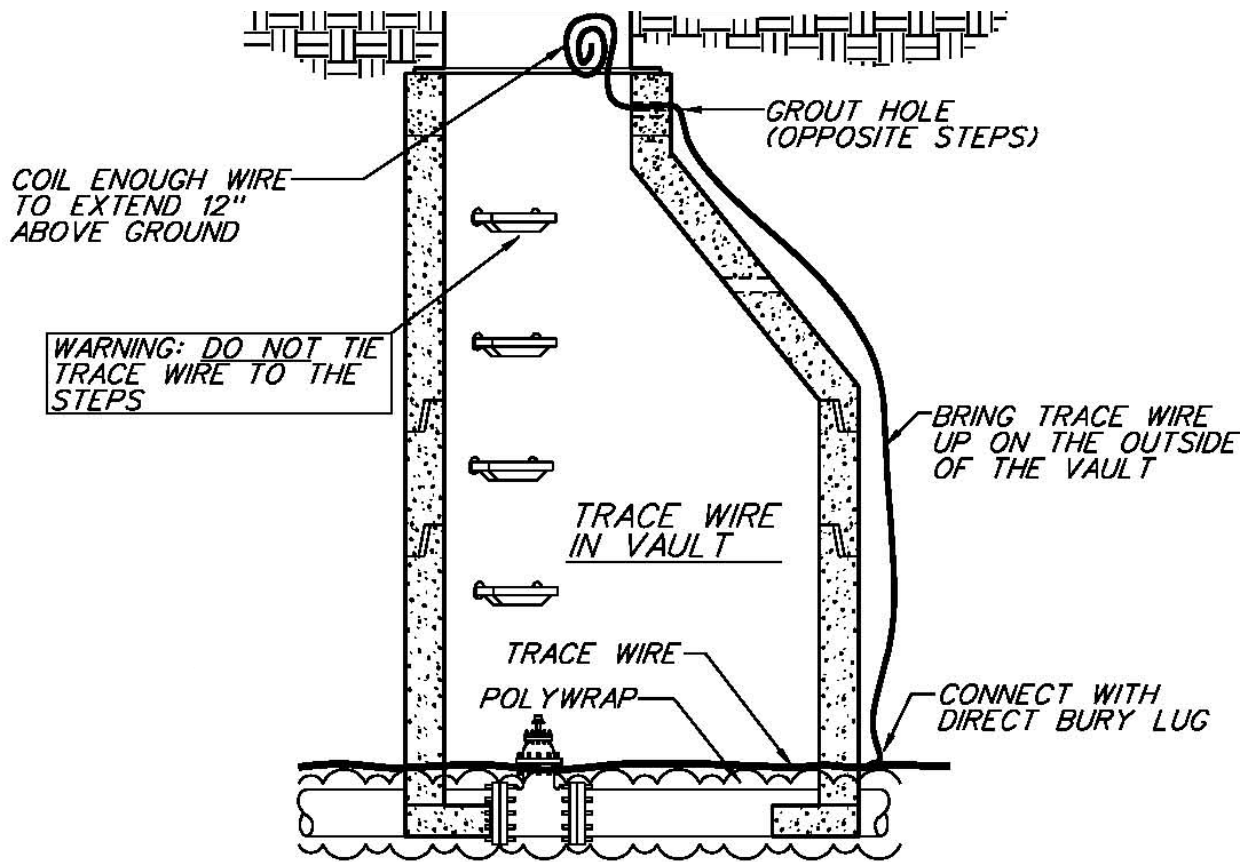

Figure 2. Trace wire access at a vault.



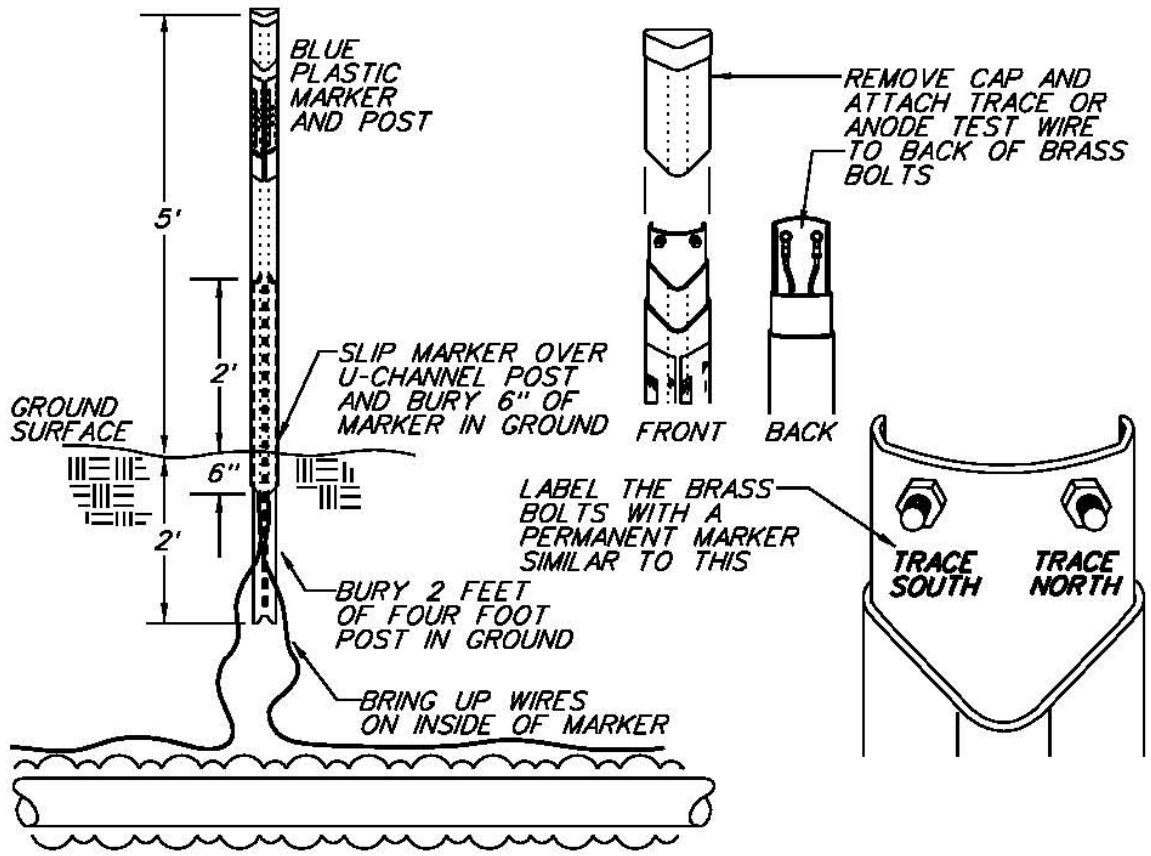

Figure 3. Trace wire access at a pipeline marker.

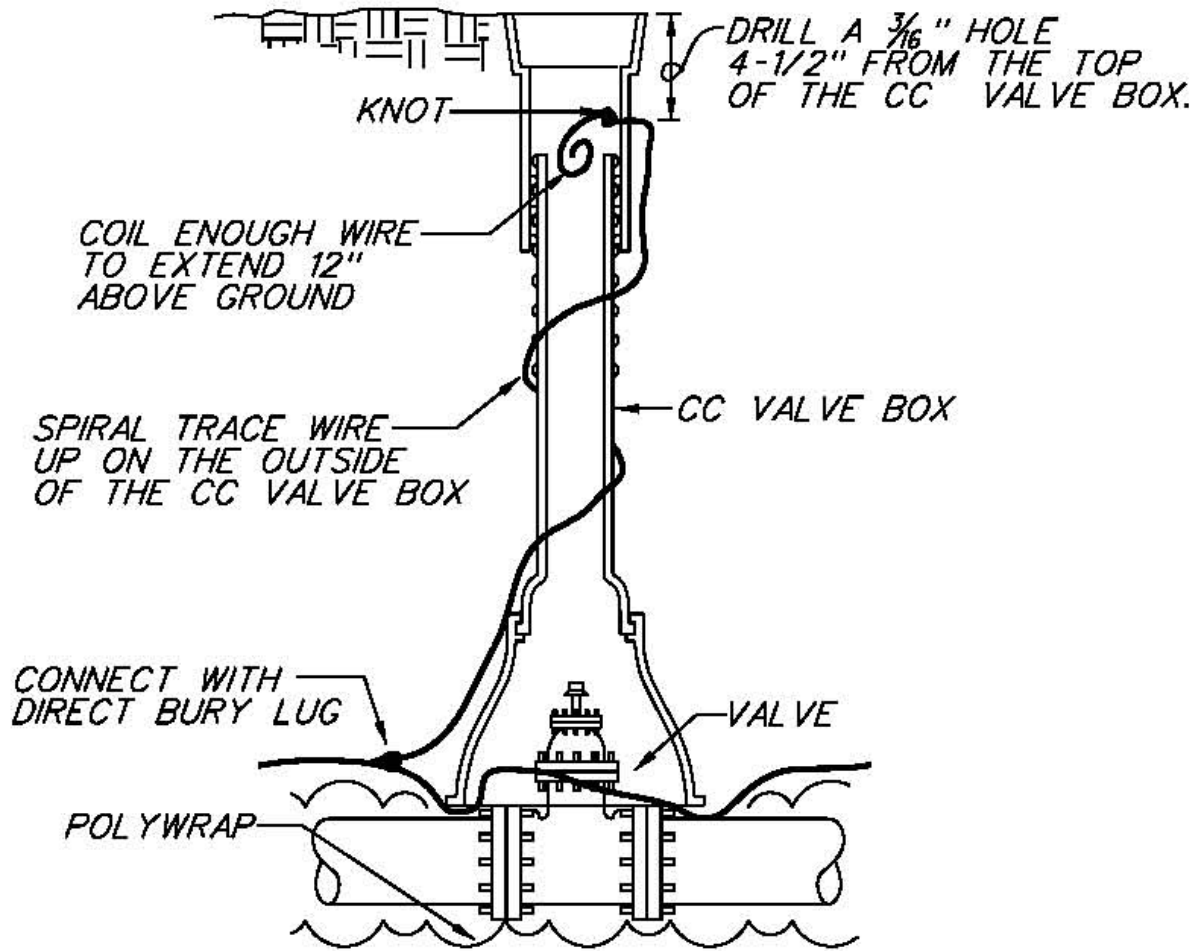

Figure 4. Trace wire access at a cc valve box.

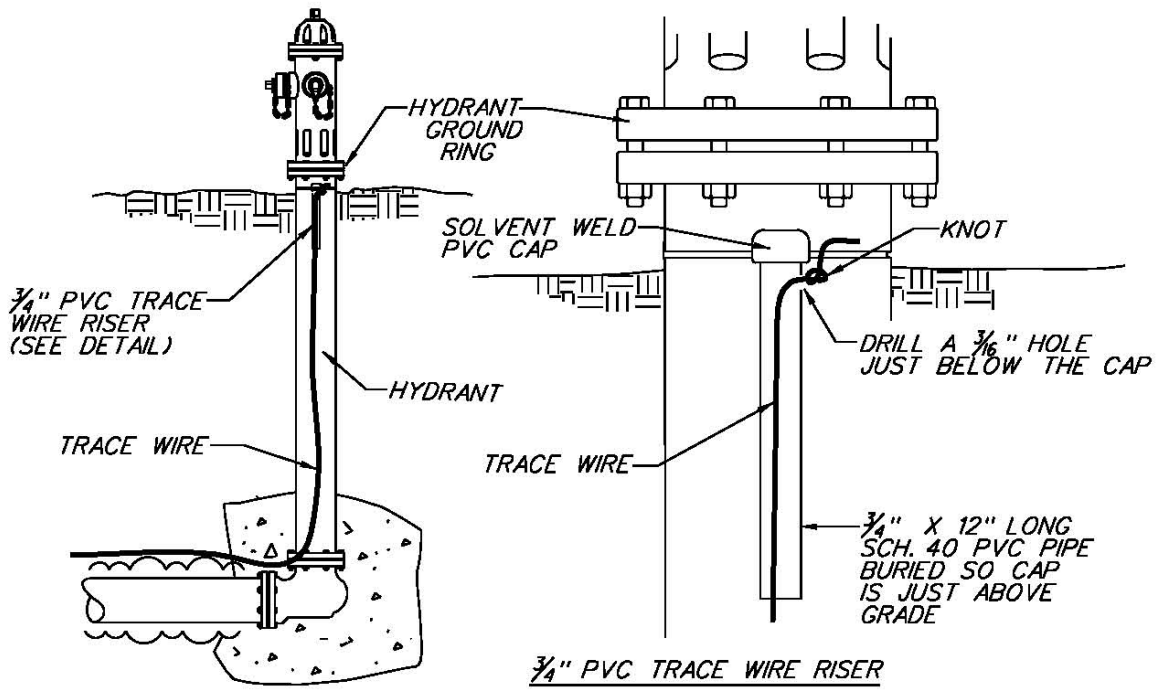
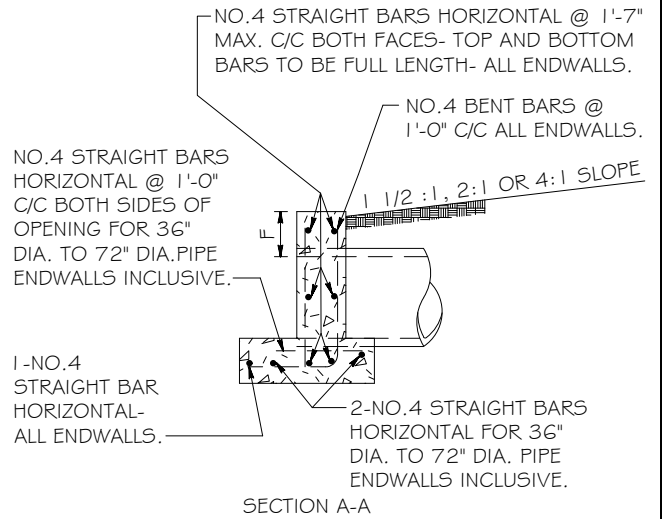
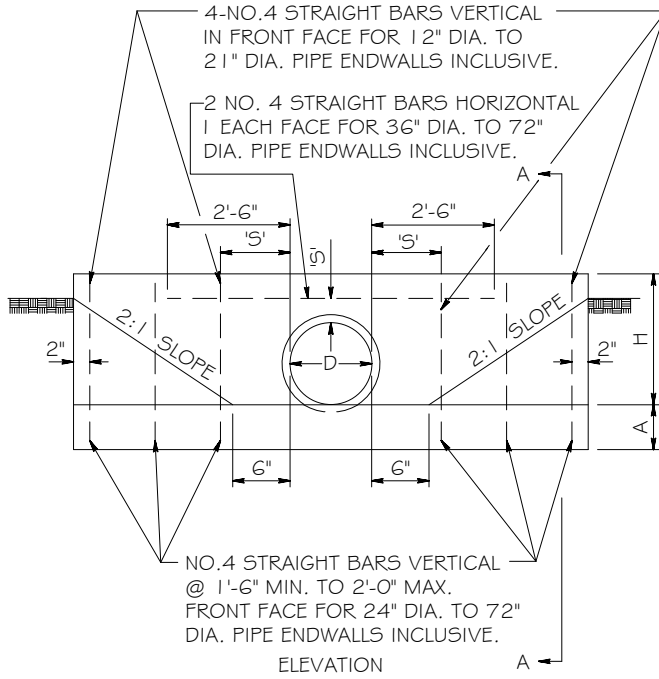
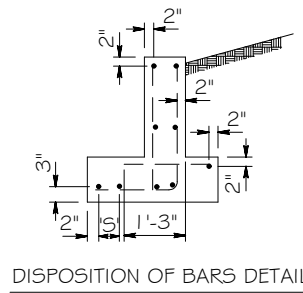
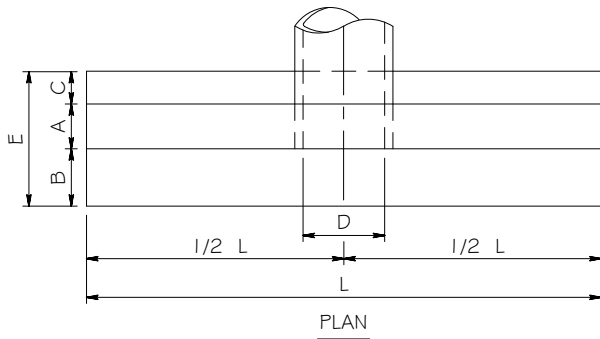

Figure 5. Trace wire access at a hydrant.

**CHAPTER 46-5**  
**CONSTRUCTION DETAILS**



QUANTITIES FOR ESTIMATING PURPOSES ONLY

OPENING		DIMENSIONS							QUANTITIES	
D INCHES	AREA SQ.FT.	A	B	C	E	F	H	L	CONC. C.Y.	STEEL LBS.
12	0.79	9"	6"	6"	1'-9"	9"	1'-9"	6'-6"	0.61	41
15	1.23	9"	6"	6"	1'-9"	9"	2'-0"	7'-9"	0.77	47
18	1.77	9"	6"	6"	1'-9"	9"	2'-3"	9'-0"	0.95	54
21	2.40	9"	6"	6"	1'-9"	9"	2'-6"	10'-3"	1.14	70
24	3.14	9"	14"	6"	2'-5"	9"	2'-9"	11'-6"	1.56	80
27	3.98	9"	14"	6"	2'-5"	9"	3'-0"	12'-10"	1.82	88
30	4.91	9"	14"	6"	2'-5"	12"	3'-6"	14'-2"	2.22	98
33	5.94	9"	14"	6"	2'-5"	12"	3'-9"	15'-5"	2.48	105
36	7.07	12"	16"	10"	3'-2"	12"	4'-0"	16'-8"	4.16	182
42	9.62	12"	16"	10"	3'-2"	12"	4'-6"	19'-2"	5.07	206
48	12.57	12"	16"	10"	3'-2"	12"	5'-0"	21'-8"	6.09	244
54	15.90	12"	20"	12"	3'-8"	12"	5'-6"	24'-2"	7.62	275
60	19.64	12"	20"	12"	3'-8"	12"	6'-0"	26'-8"	8.82	304
72	28.27	12"	20"	12"	3'-8"	12"	7'-0"	31'-8"	11.46	377

'S' DISTANCES

- 4" FOR 12" DIA. TO 21" DIA. PIPES INCLUSIVE.
- 6" FOR 24" DIA. TO 36" DIA. PIPES INCLUSIVE.
- 8" FOR 42" DIA. TO 72" DIA. PIPES INCLUSIVE.

NOTES:

- SPECIFICATIONS: LATEST TOWN OF MIDDLETOWN
- CONCRETE SHALL BE CLASS B
- REINFORCING: DEFORMED STEEL BARS-NO.4
- CHAMFER: ALL EXPOSED EDGES 1"x1" OR AS DIRECTED
- SAFETY GRATING REQUIRED IN RESIDENTIAL AREAS ON UPSTREAM HEADWALLS

ISSUED	2010
REVISED	
SOURCE	MDSHA





DEPARTMENT OF PUBLIC WORKS

# STRAIGHT HEADWALL

STORM DRAINAGE DETAILS

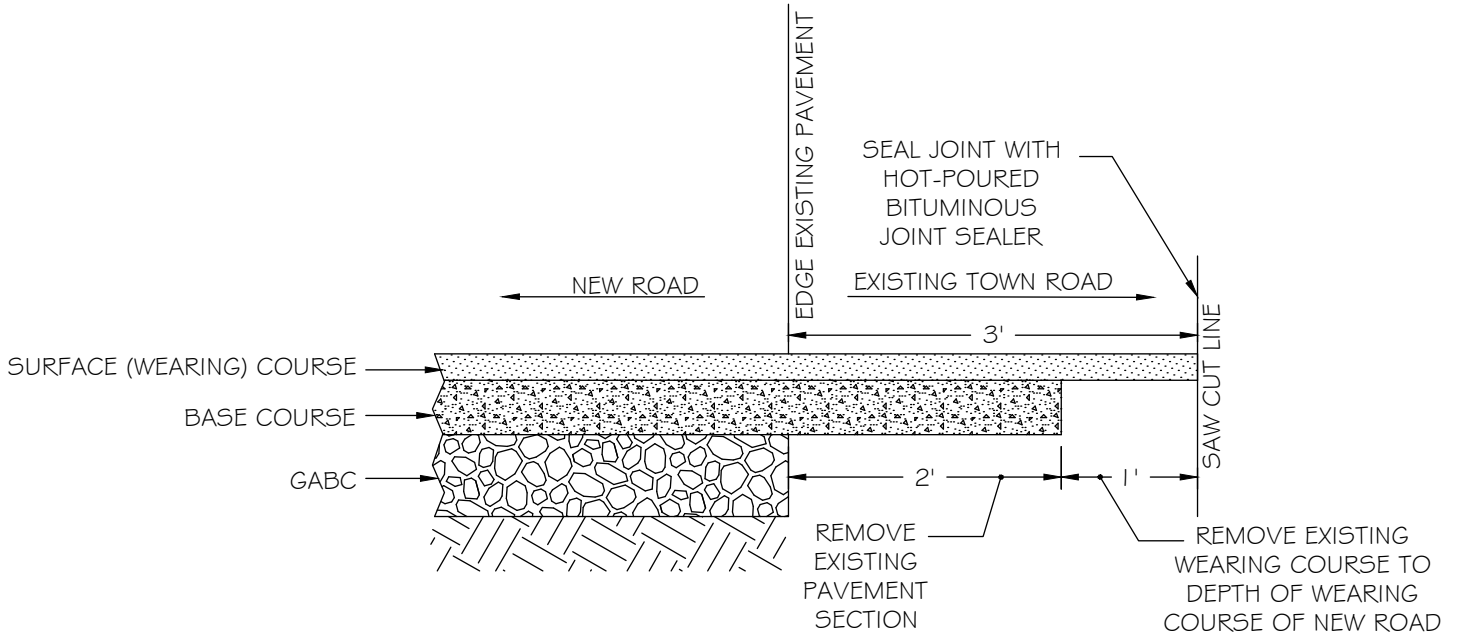
STANDARD NO. D-1



ISSUED	2010		PAVEMENT TIE-IN SECTION
REVISED			
			ROAD DETAILS
SOURCE			DEPARTMENT OF PUBLIC WORKS

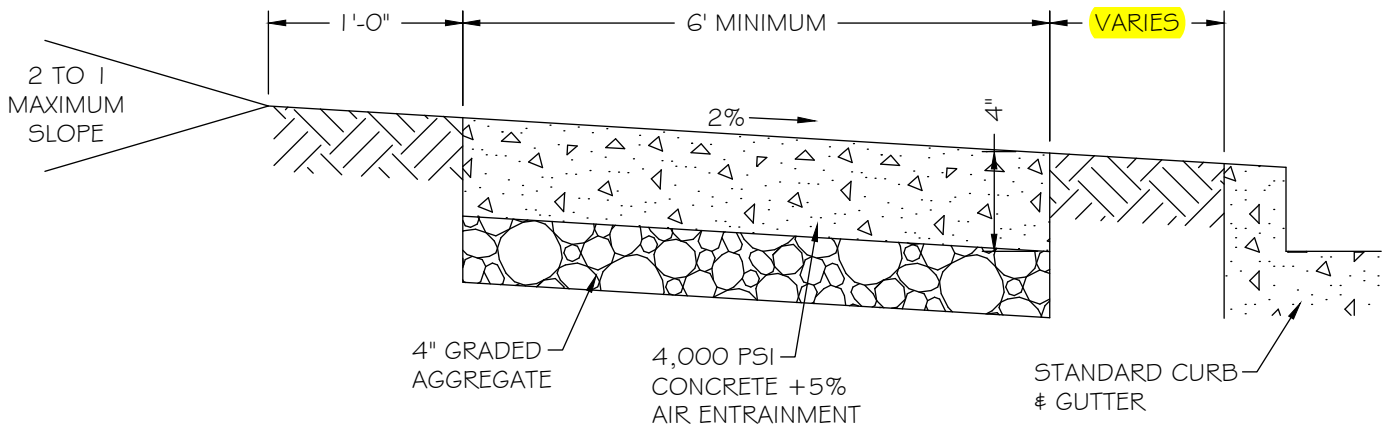

NOTES:

1. TWENTY-EIGHT (28) DAY SPECIFIED COMPRESSIVE STRENGTH FOR CONCRETE MIX SHALL BE A MINIMUM OF 4,000 PSI.
2. ALL SIDEWALK SHALL BE FOUR INCHES (4") MINIMUM THICKNESS OVER FOUR INCHES (4") OF GABC, UNLESS OTHERWISE NOTED.
3. SIDEWALK ACROSS DRIVEWAYS AND DRIVEWAY APRONS SHALL BE SIX INCHES (6") MINIMUM THICKNESS, UNLESS OTHERWISE NOTED OVER SIX INCHES (6") GABC.
4. SIDEWALKS SHALL HAVE DUMMY JOINTS EVERY FIVE FEET (5') AND SHALL HAVE EXPANSION JOINTS INSTALLED EVERY TWENTY FEET (20').
5. A PVC SLEEVE OF FOUR INCHES (4") IN DIAMETER, INSTALLED TO A DEPTH OF A LEAST TWELVE INCHES (12") BELOW FINISHED GRADE AND INTO SOIL, SHALL BE PROVIDED FOR EACH SIGN POST LOCATED WITHIN THE SIDEWALK PRIOR TO INSTALLATION OF CONCRETE MIX.
6. ALL UNPAVED AREAS WITHIN RIGHT-OF-WAY SHALL BE SEEDED AND MULCHED WITH A MINIMUM OF SIX INCHES (6") OF TOP SOIL OR SODDED TO OBTAIN A THICK STAND OF GRASS.

ISSUED	2010	 DEPARTMENT OF PUBLIC WORKS	SIDEWALK
REVISED	2021		ROAD DETAILS
			STANDARD NO. R-2
SOURCE			

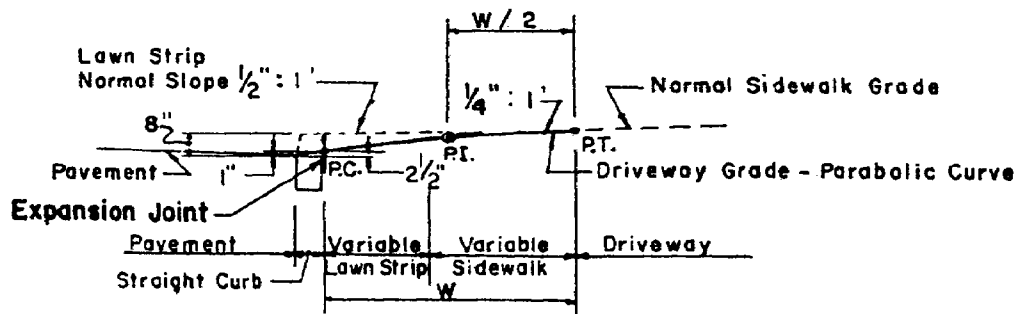
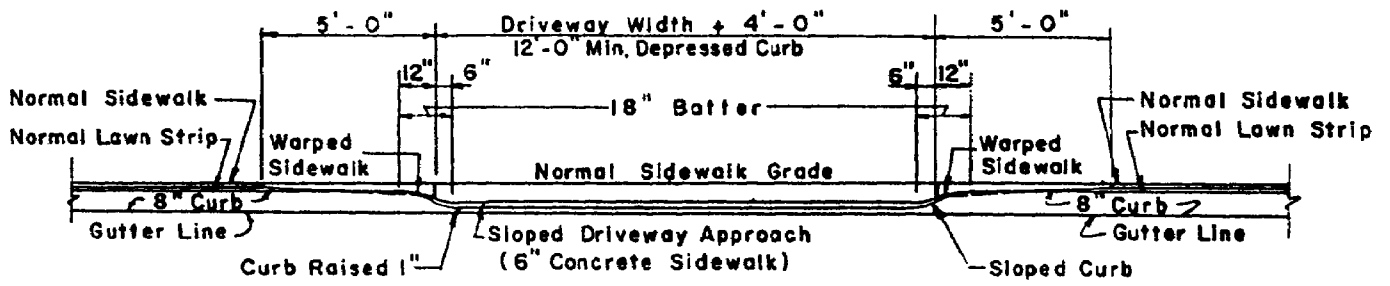
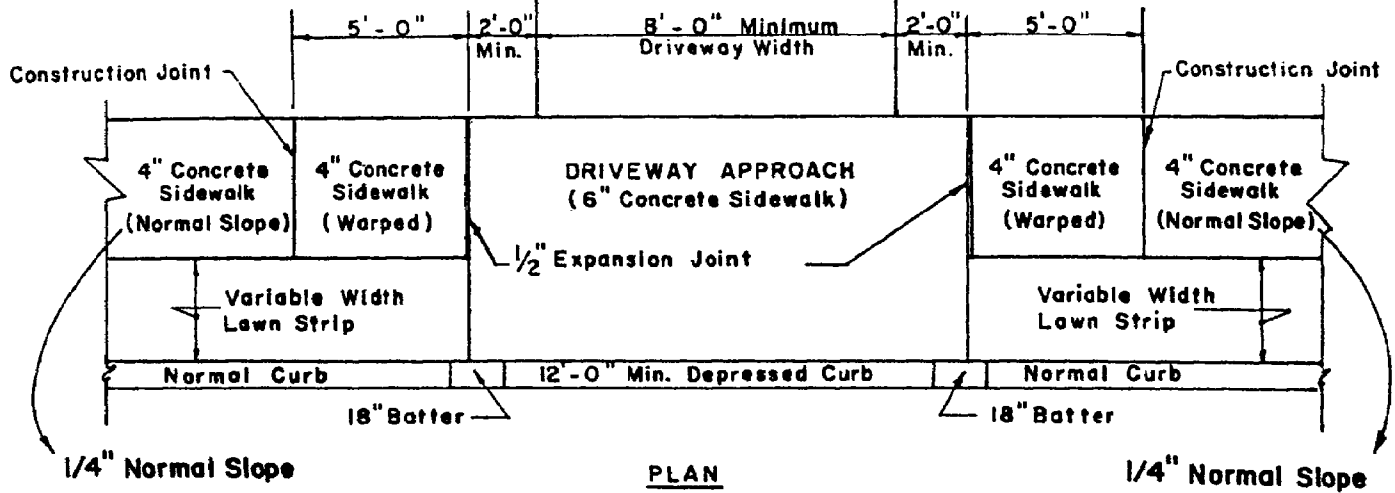

(No Scale)

ISSUED	2010
REVISED	
SOURCE	



DEPARTMENT OF PUBLIC WORKS

## RESIDENTIAL ENTRANCE (WITH GRASS STRIP)

ROAD DETAILS

STANDARD NO. R-3



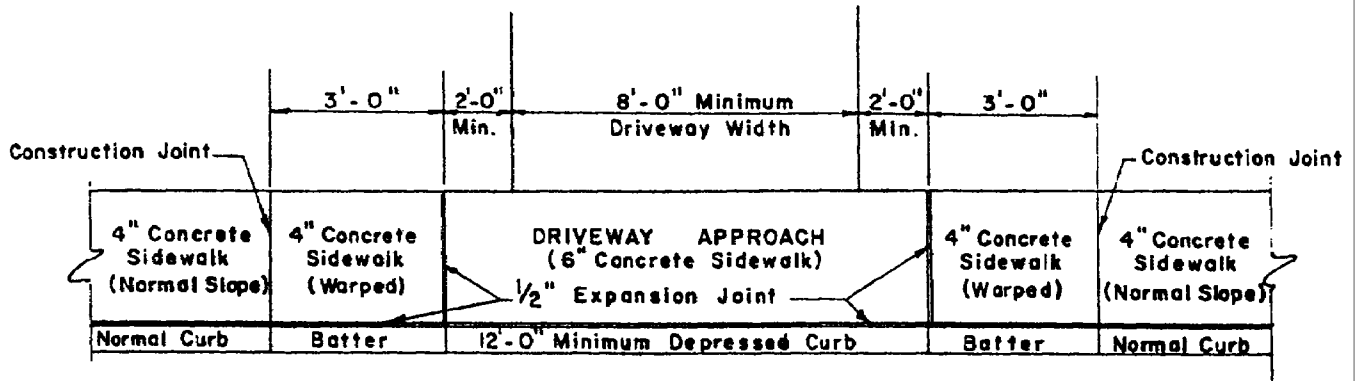

PLAN

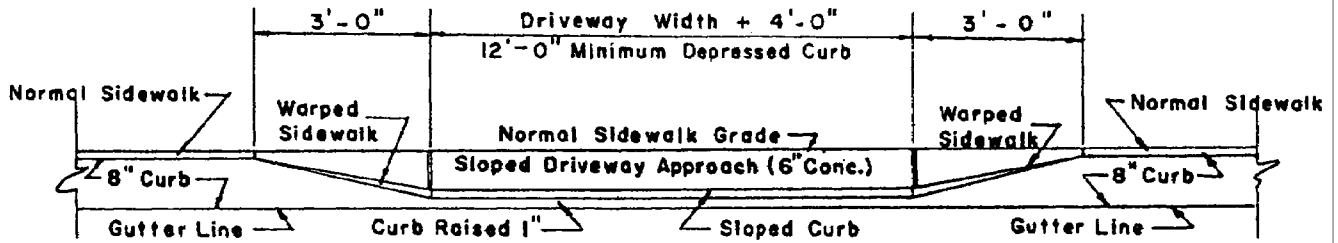

FRONT VIEW

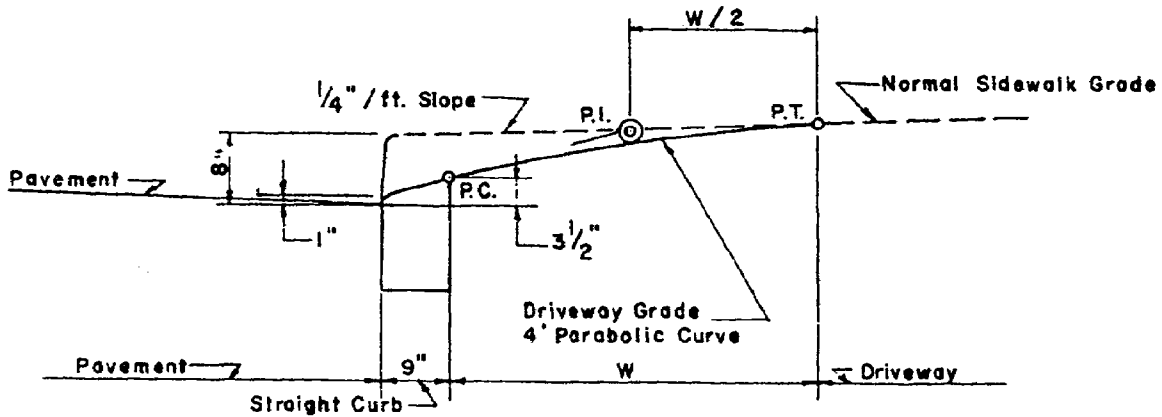

PROFILE OF DRIVEWAY

(No Scale)

ISSUED	2010		RESIDENTIAL ENTRANCE (WITHOUT GRASS STRIP)	
REVISED			ROAD DETAILS	
SOURCE			DEPARTMENT OF PUBLIC WORKS	STANDARD NO. R-4

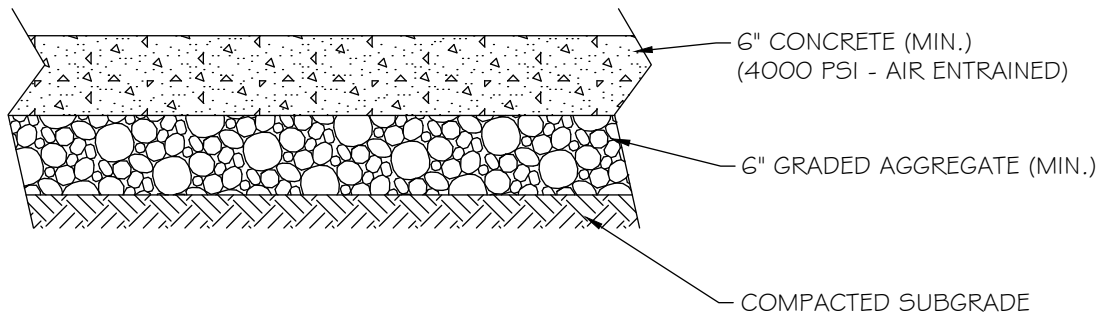

ISSUED	2010		RESIDENTIAL DRIVEWAY SECTION (CONCRETE)	
REVISED				
			ROAD DETAILS	
SOURCE			DEPARTMENT OF PUBLIC WORKS	STANDARD NO. R-5

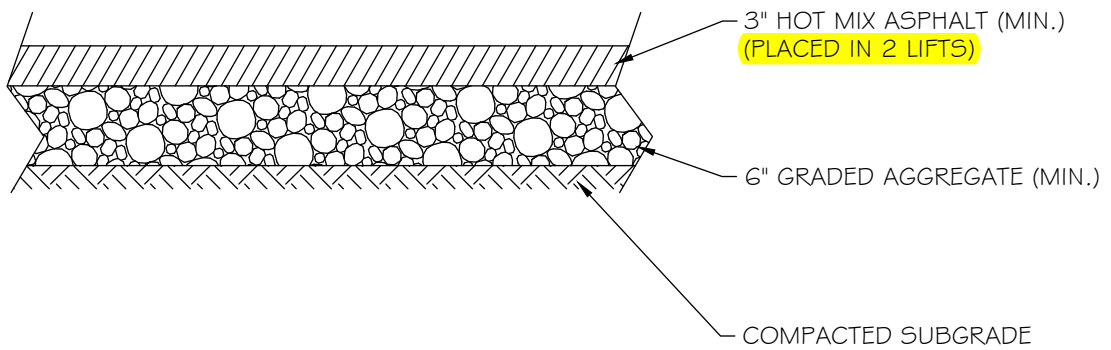

ISSUED	2010		RESIDENTIAL DRIVEWAY SECTION (ASPHALT)	
REVISED	2021		ROAD DETAILS	
			DEPARTMENT OF PUBLIC WORKS	STANDARD NO. R-6
SOURCE				

MINIMUM DESIGN REQUIREMENTS  
(PUBLIC WORKS DEPARTMENT MAY CHANGE REQUIREMENTS IN SPECIAL CASES)

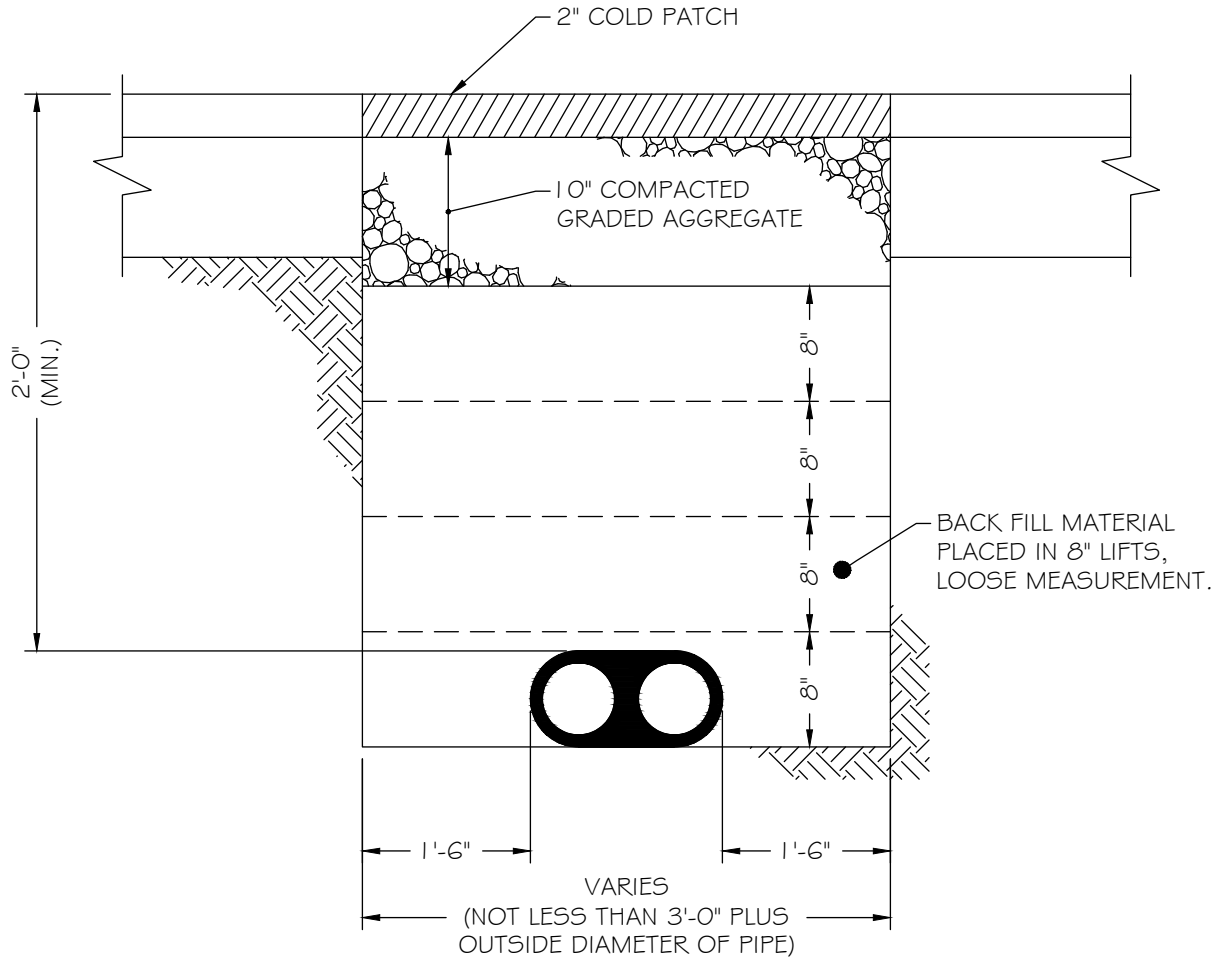

NOTES:

1. ALL MATERIALS AND METHODS OF CONSTRUCTION SHALL MEET THE REQUIREMENTS SET FORTH IN THE CURRENT TOWN OF MIDDLETOWN STANDARD SPECIFICATIONS AND DETAILS FOR STREETS AND ROAD.

ISSUED	2010		TEMPORARY ROADWAY PATCH
REVISED			ROAD DETAILS
			STANDARD NO. R-7
SOURCE			DEPARTMENT OF PUBLIC WORKS

PATCHES MUST HAVE A MINIMUM LENGTH OF 7 FEET PLUS OUTSIDE DIAMETER OF PIPE (AS MEASURED ALONG THE ROADWAY CENTERLINE) AND THE WIDTH OF THE LANE OR LANES DISTURBED.

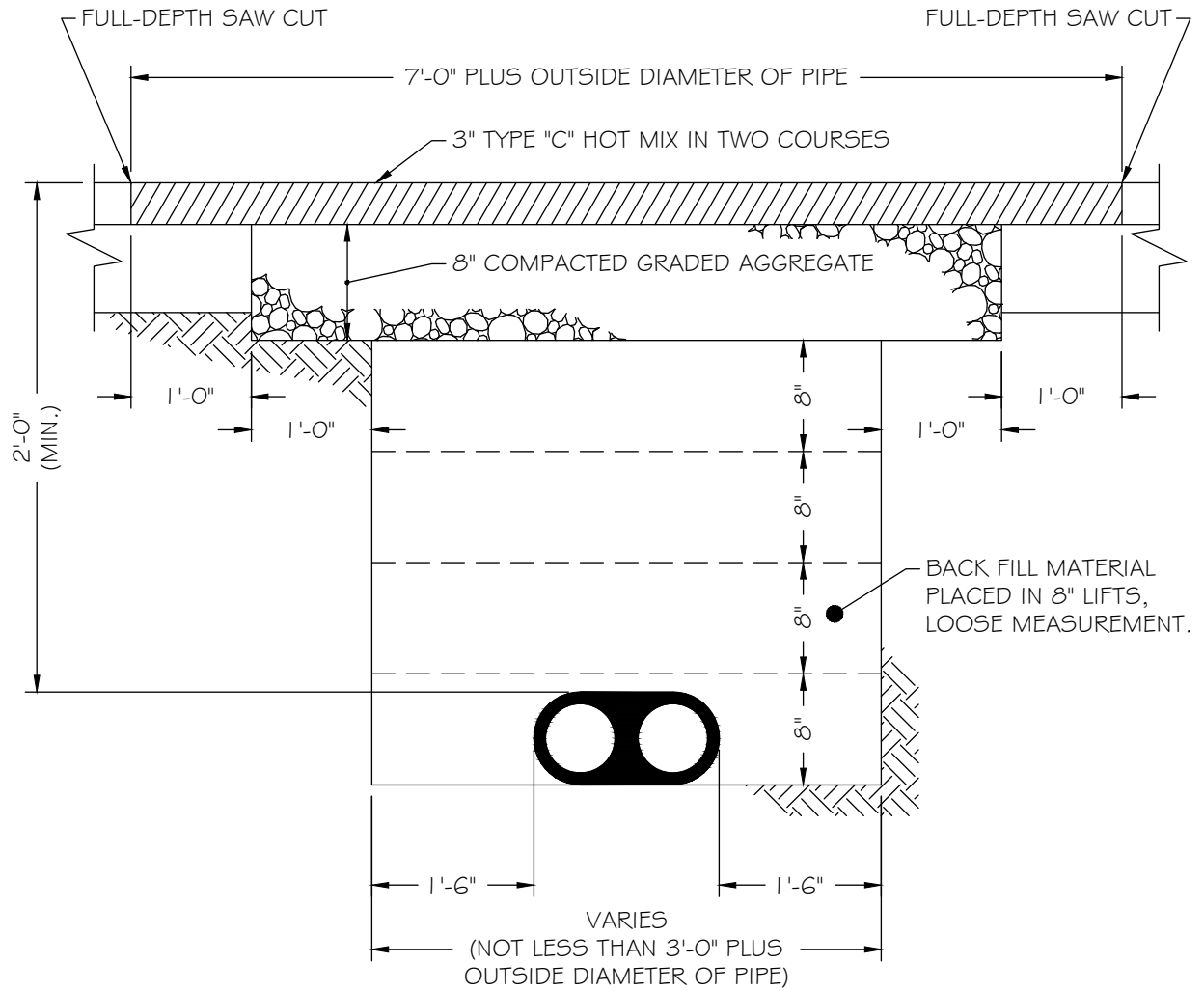

NOTES:

1. THIS IS A MINIMUM PATCH. IF THE EXISTING ROADWAY HAS A HEAVIER CROSS SECTION THAN SHOWN HERE, IT WILL BE REPLACED WITH THAT CROSS SECTION, OR AS DIRECTED BY THE PUBLIC WORKS DIRECTOR.
2. ALL MATERIALS AND METHODS OF CONSTRUCTION SHALL MEET THE REQUIREMENTS SET FORTH IN THE CURRENT TOWN OF MIDDLETOWN STANDARD SPECIFICATIONS AND DETAILS FOR STREETS AND ROADS.

ISSUED	2010	 DEPARTMENT OF PUBLIC WORKS	PERMANENT ROADWAY PATCH
REVISED			ROAD DETAILS
			STANDARD NO. R-8
SOURCE			

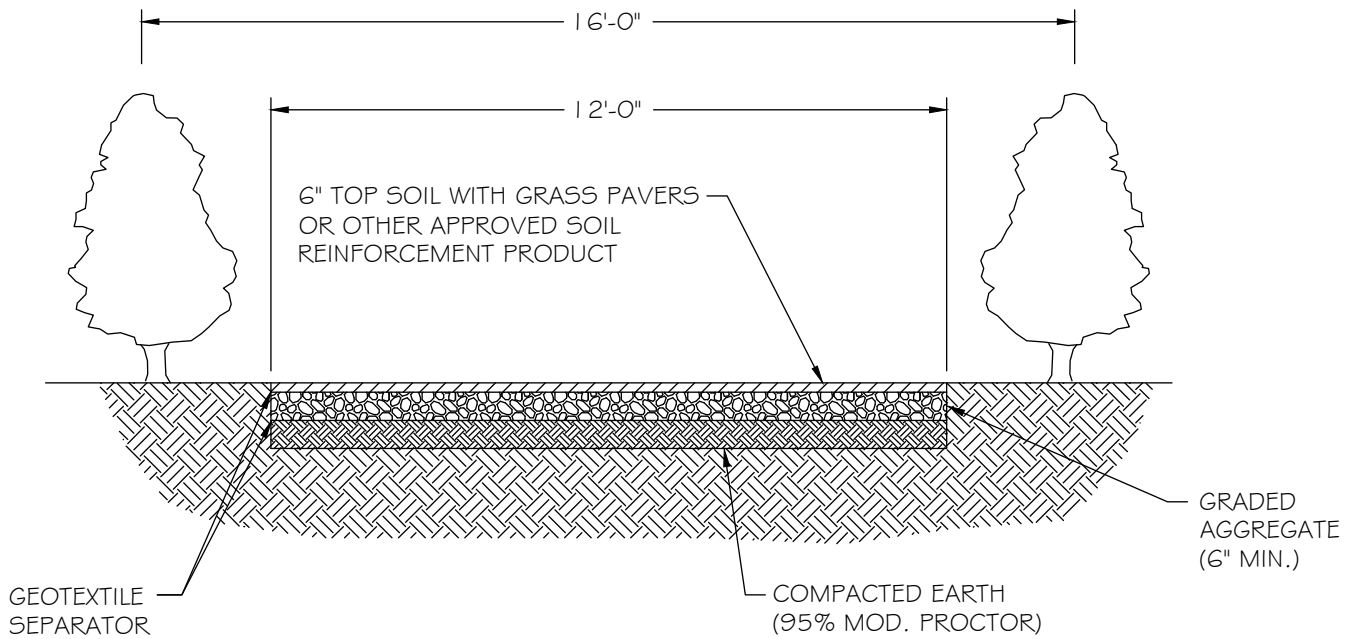

NOTES:

1. MINIMUM WIDTH: 16'-0"
2. TREES/SHRUBS: MINIMUM 3'-0" MAXIMUM 5'-0" IN HEIGHT AT 20'-0" O.C.
3. REFER TO DELAWARE STATE FIRE PREVENTION REGULATIONS FOR ALL REQUIREMENTS.
4. GEOTEXTILE SEPARATOR TO BE INSTALLED BOTH ABOVE AND BELOW GRADED AGGREGATE BASE.

ISSUED	2010		FORESTRY LANE	
REVISED			ROAD DETAILS	
			DEPARTMENT OF PUBLIC WORKS	STANDARD NO. R-9
SOURCE				

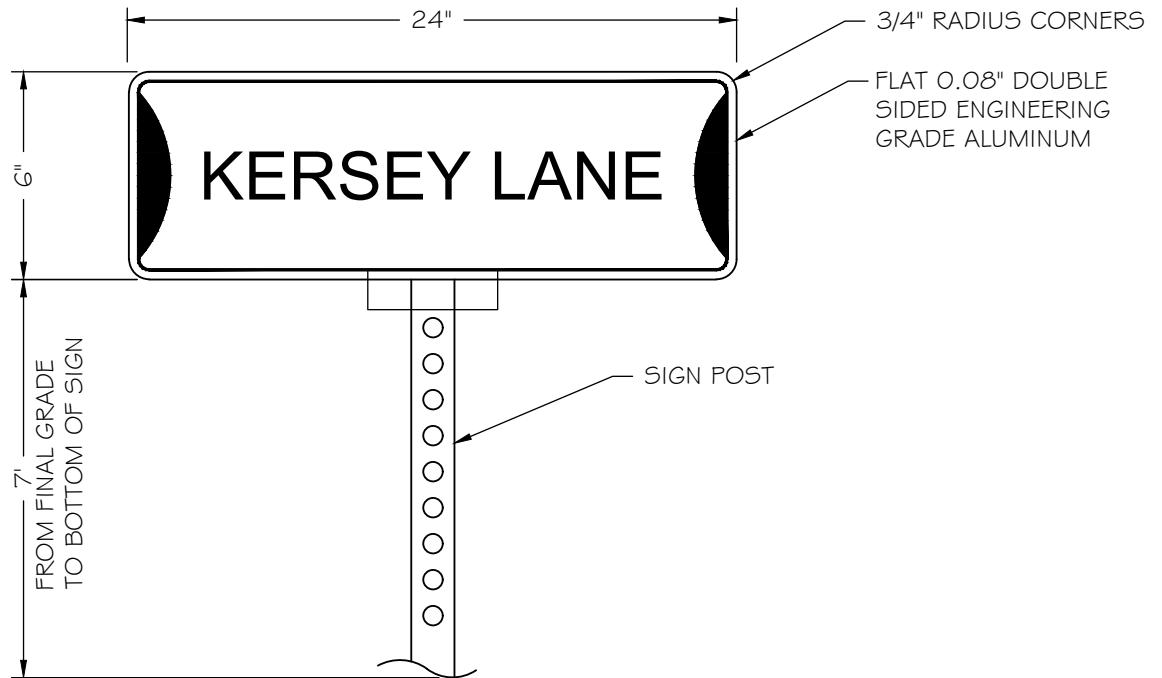

NOTES:

STREET NAME SIGNS (BLADES):

- A. STREET NAME SIGN SHALL BE ORDERED BY THE DEVELOPER.
- B. STREET NAME SIGNS SHALL BE AS FOLLOWS:
  - 1. SIZE: 24" WIDE BY 6" TALL
  - 2. BACKGROUND: WHITE REFLECTIVE, HIGH INTENSITY PRISMATIC (HIP) MEETING ASTM D4956 TYPE IV
  - 3. BLADE MATERIAL: FLAT 0.080" DOUBLE SIDED ENGINEERING GRADE ALUMINIUM WITH 3/4" RADIUS CORNERS.
  - 4. TEXT FRONT: HIGHWAY GOTHIC NARROW
  - 5. TEXT COLOR: BLACK 10 YEAR VINYL
  - 6. BORDER COLOR: BLACK 10 YEAR VINYL
- C. COLOR SHALL MEET OFFICIAL MUTCD STANDARD

SIGN POSTS:

STREET SIGN SHALL BE INSTALLED ON A TELESCOPING SIGN POST WHICH SHALL BE SUPPLIED AND INSTALLED AS A COMPLETE UNIT INCLUSIVE OF ONE (1) SPECIFIED LENGTH OF 2 INCH SQUARE SIGN POST, ONE (1) 36" X 2-1/4" BASEPOST, ONE (1) CORNER BOLT AND ONE (1) NUT. SIGN POST MATERIALS SHALL BE IN ACCORDANCE WITH SECTION 1072 OF THE AUGUST 2016 EDITION OF THE DELDOT STANDARD SPECIFICATION FOR ROAD AND BRIDGE CONSTRUCTION. THE MINIMUM DISTANCE FROM THE FINAL GRADE TO THE BOTTOM OF THE SIGN SHALL BE SEVEN (7) FEET.

ISSUED	2021	 DEPARTMENT OF PUBLIC WORKS	STREET NAME SIGNS (BLADES)
REVISED			ROAD DETAILS
			STANDARD NO. R-10
SOURCE			

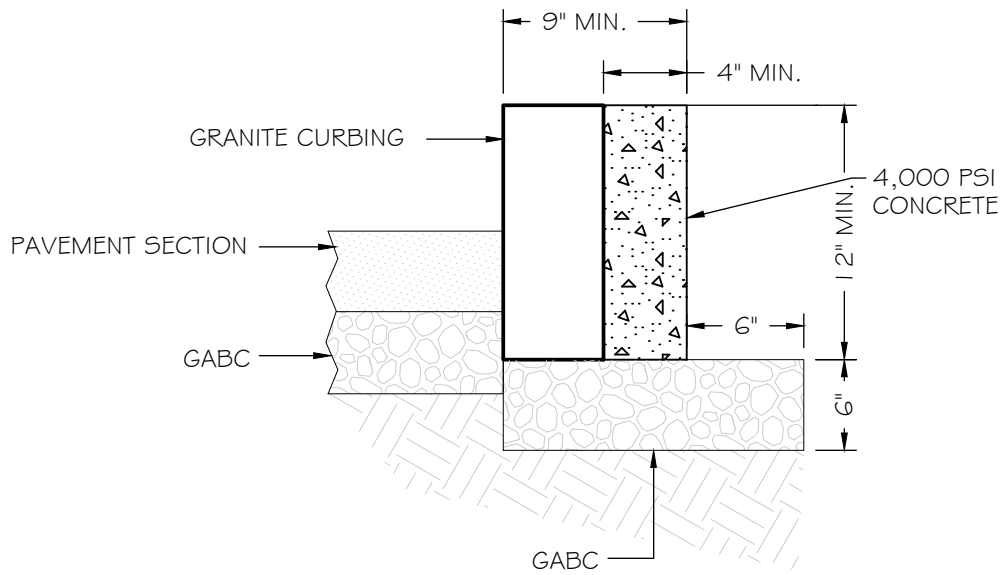

ISSUED	2021	 DEPARTMENT OF PUBLIC WORKS	GRANITE CURB REPLACEMENT
REVISED			ROAD DETAILS
			STANDARD NO. R-11
SOURCE			



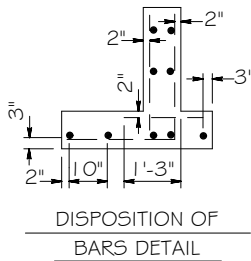
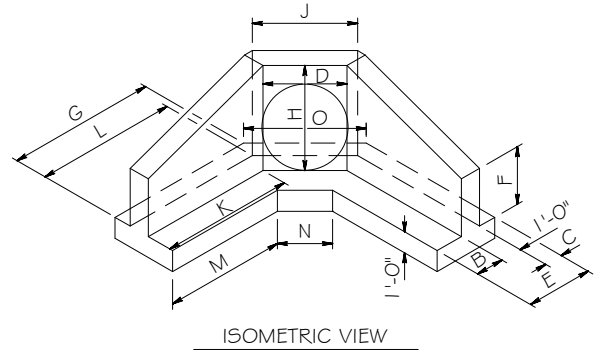
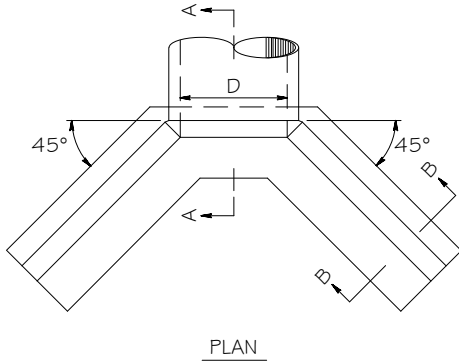
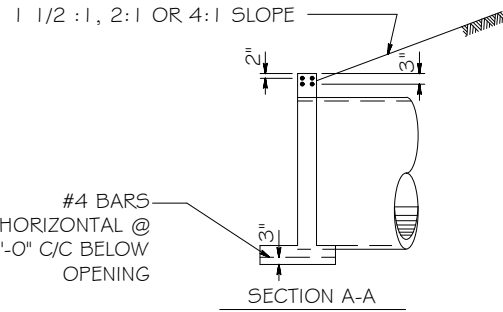
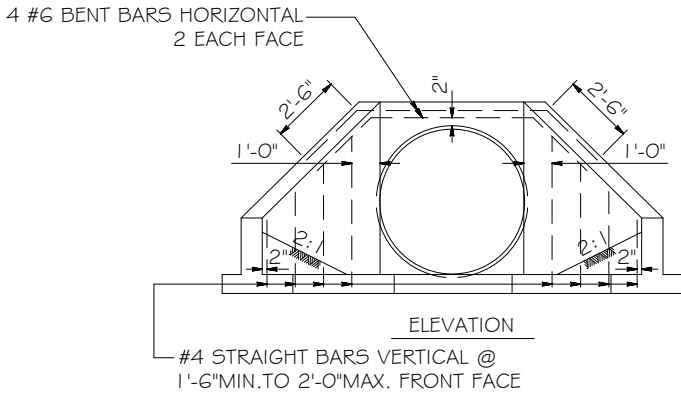

#4 BARS HORIZONTAL @ 1'-7" MAX. C/C  
BOTH FACES BOTTOM BARS BENT ALONG  
ENDWALL OTHERS STRAIGHT.

1 #4 BENT BAR HORIZONTAL

1 #4 BENT BAR HORIZONTAL

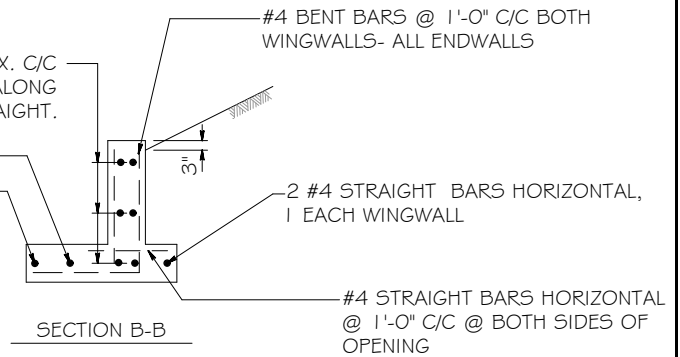

NOTES

SPECIFICATIONS: LATEST TOWN OF MIDDLETOWN

CONCRETE SHALL BE CLASS B

REINFORCING: DEFORMED STEEL BARS #4 & #6

CHAMFER: ALL EXPOSED EDGES 1"X1" OR AS DIRECTED

SAFETY GRATING REQUIRED IN RESIDENTIAL AREAS ON UPSTREAM HEADWALLS

OPENING		DIMENSIONS												VOL. CONC. C.Y.	STEEL LBS.
D INCHES	AREA SQ.FT.	B	C	E	F	G	H	J	K	L	M	N	O		
48	12.57	1'-4"	10"	3'-2"	2'-9"	7'-0 3/4 "	5'-0"	4'-10"	6'-3 1/2"	6'-8 1/2"	5'-9"	2'-10 3/4"	5'-6"	4.3	262
54	15.9	1'-8"	1'-0"	3'-8"	3'-0"	7'-8 1/2 "	5'-6"	5'-4"	6'-10 1/2"	7'-3 1/2"	6'-2 1/4"	3'-1 1/2"	6'-2"	5.3	301
60	19.64	1'-8"	1'-0"	3'-8"	3'-3"	8'-5"	6'-0"	5'-10"	7'-7 1/4"	8'-0 1/4"	6'-11"	3'-7 1/2 "	6'-8"	6.0	361

QUANTITIES IN TABLE TO BE USED FOR ESTIMATING ONLY

ISSUED	2010		<p>STANDARD HEADWALL (48", 54" &amp; 60" PIPE)</p>
REVISED			
SOURCE	MDSHA	DEPARTMENT OF PUBLIC WORKS	STANDARD NO. D-2

4-#6 BENT BARS HORIZONTAL  
2 EACH FACE

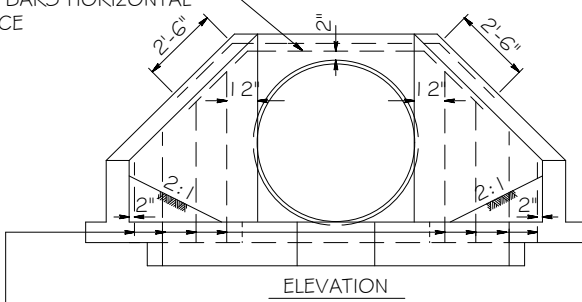

ELEVATION

#4 STRAIGHT BARS VERTICAL  
@ 1'-6" MIN. TO 2'-0" MAX. IN  
FRONT FACE

1 1/2 : 1, 2:1 OR 4:1 SLOPE

3/4" O HOOK BOLTS @ 1'-6"  
C/C AROUND PIPE ARCH WHEN  
METAL PIPE IS USED.

#4 BENT BARS @  
1'-0" C/C BELOW  
OPENING

SECTION A-A

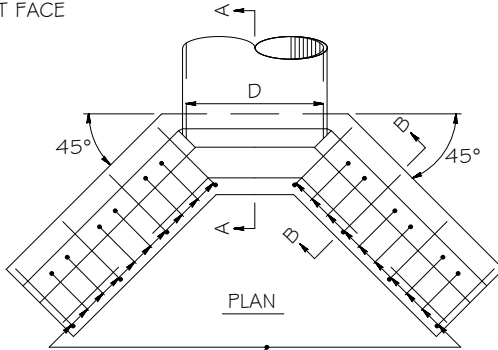

PLAN

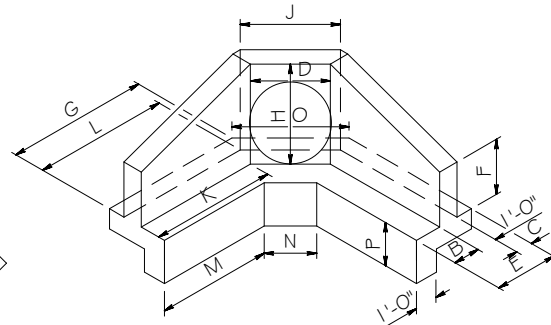

ISOMETRIC VIEW

- B-66 { #4 LONG BENT BARS HORIZONTAL
- B-72 { #4 SHORT BENT BARS HORIZONTAL
- ALT. 1 WITH 1 @ 6"C/C
- B-78 { #4 LONG BENT BARS HORIZONTAL
- B-84 { #4 SHORT BENT BARS HORIZONTAL
- ALT. 1 WITH 2 RESP. 4"C/C

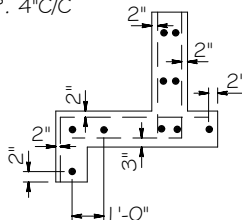

DISPOSITION OF  
BARS DETAIL

#4 BARS HORIZONTAL @ 1'-7"  
MAX. C/C BOTH FACES BOTTOM  
BARS BENT ALONG ENDWALL  
OTHERS STRAIGHT.

1 #4 BENT BAR HORIZONTAL  
2 #4 BENT BARS  
HORIZONTAL

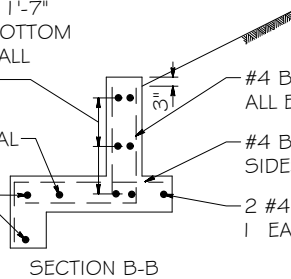

SECTION B-B

#4 BENT BARS BOTH WINGWALLS  
ALL ENDWALLS.  
#4 BENT BARS @ 1'-0" C/C BOTH  
SIDES OF OPENING  
2 #4 STRAIGHT BARS HORIZONTAL,  
1 EACH WINGWALL

NOTES

SPECIFICATIONS: LATEST TOWN OF SMYRNA CONCRETE SHALL BE CLASS B  
REINFORCING: DEFORMED STEEL BARS #4 & #6  
CHAMFER: ALL EXPOSED EDGES 1"x1" OR AS DIRECTED  
SAFETY GRATING REQUIRED IN RESIDENTIAL AREAS ON UPSTREAM HEADWALLS

OPENING		DIMENSIONS													VOL. CONC. C.Y.	STEEL LBS.
D INCHES	AREA SQ.FT.	B	C	E	F	G	H	J	K	L	M	N	O	P		
66	23.80	2'-6"	1'-3"	4'-9"	3'-0"	11'-2 1/2"	6'-8 1/2"	6'-4"	10'-3 1/4"	10'-8 1/2"	9'-3"	3'-5"	7'-4 1/2"	2'-0"	9.7	585
72	28.27	2'-6"	1'-3"	4'-9"	3'-3"	12'-1"	7'-3"	6'-10"	11'-1 3/4"	11'-6 3/4"	10'-1 1/4"	3'-11"	7'-10 1/2"	2'-0"	10.9	645
78	33.20	3'-0"	1'-6"	5'-6"	3'-6"	13'-0 1/2"	7'-9 1/2"	7'-4"	12'-0"	12'-5"	10'-9"	4'-0"	8'-6 3/4"	2'-6"	13.3	865
84	38.48	3'-0"	1'-6"	5'-6"	3'-9"	13'-10"	8'-4"	7'-10"	12'-9 1/2"	13'-2 1/2"	11'-6 1/2"	4'-6"	9'-0 3/4"	2'-6"	14.7	984

QUANTITIES IN TABLE TO BE USED FOR ESTIMATING ONLY

ISSUED	2010		<h2 style="text-align: center;">45° STANDARD HEADWALL (66" TO 84" PIPE)</h2>
REVISED			
SOURCE	MDSHA	DEPARTMENT OF PUBLIC WORKS	STORM DRAINAGE DETAILS
			STANDARD NO. D-3

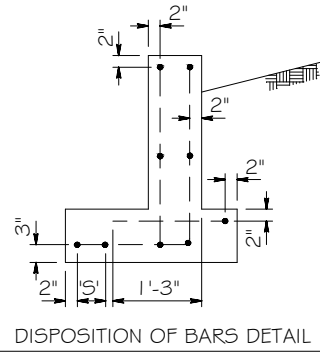
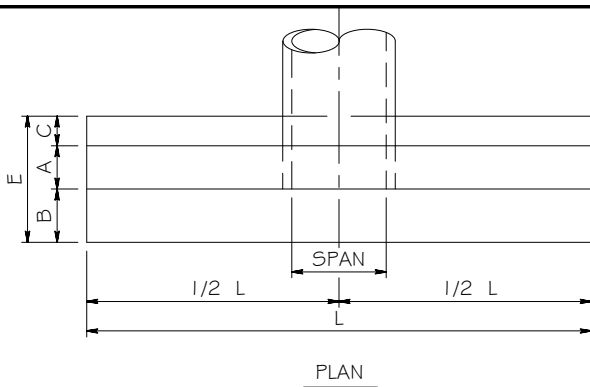

4-NO.4 STRAIGHT BARS VERTICAL IN FRONT FACE FOR 14"x23" TO 19"x30" PIPE ENDWALLS.

2-NO.4 STRAIGHT BARS HORIZONTAL 1 EACH FACE FOR 32"x49" TO 43"x68" PIPE ENDWALLS INCLUSIVE.

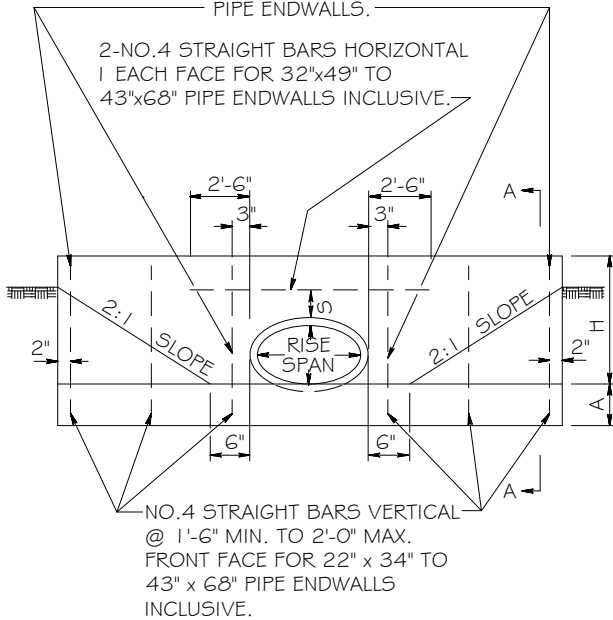

NO.4 STRAIGHT BARS VERTICAL @ 1'-6" MIN. TO 2'-0" MAX. FRONT FACE FOR 22" x 34" TO 43" x 68" PIPE ENDWALLS INCLUSIVE.

ELEVATION

NO.4 STRAIGHT BARS HORIZONTAL @ 1'-7" MAX. C/C BOTH FACES- TOP AND BOTTOM BARS TO BE FULL LENGTH- ALL ENDWALLS.

NO.4 STRAIGHT BARS HORIZONTAL @ 1'-0" C/C BOTH SIDES OF OPENING FOR 32"x49" TO 43"x64" PIPE ENDWALLS INCLUSIVE.

1-NO.4 STRAIGHT BAR HORIZONTAL ALL ENDWALLS.

NO.4 BENT BARS @ 1'-0" C/C ALL ENDWALLS.

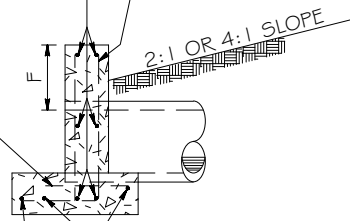

2-NO.4 STRAIGHT BARS HORIZONTAL FOR 32"x49" TO 43"x68" PIPE ENDWALLS INCLUSIVE.

SECTION A-A

QUANTITIES FOR ESTIMATING PURPOSES ONLY

OPENING		DIMENSIONS							QUANTITIES	
D	AREA	A	B	C	E	F	H	L	CONC. C.Y.	STEEL LBS.
RISE x SPAN INCHES	SQ. FT.									
14X23	1.8	9"	8"	6"	1'-11"	12"	2'-2"	8'-7"	0.88	56
19X30	3.3	9"	8"	6"	1'-11"	12"	2'-6"	10'-6"	1.15	63
22X34	4.1	9"	14"	6"	2'-5"	13"	2'-11"	12'-6"	1.74	100
24X38	5.1	9"	14"	6"	2'-5"	13"	3'-1"	13'-6"	1.92	116
27X42	6.3	9"	14"	6"	2'-5"	13"	3'-4"	14'-10"	2.19	124
29X45	7.4	9"	14"	10"	2'-9"	14"	3'-7"	16'-0"	2.61	141
32X49	8.8	12"	16"	10"	3'-2"	14"	3'-10"	17'-0"	4.08	202
34X53	10.2	12"	16"	10"	3'-2"	14"	4'-0"	18'-0"	4.40	210
38X60	12.9	12"	16"	10"	3'-2"	15"	4'-5"	20'-4"	5.23	266
43X68	16.6	12"	20"	12"	3'-8"	15"	4'-10"	22'-8"	6.52	307

'S' DISTANCES

6" FOR 14" x 23" TO 27" x 42" INCLUSIVE.  
8" FOR 29" x 45" TO 43" x 68" INCLUSIVE.

GENERAL NOTES

SPECIFICATIONS: LATEST TOWN OF SMYRNA  
CONCRETE: SHALL BE CLASS B  
REINFORCEMENT: DEFORMED STEEL BARS NO.4  
CHAMFER: ALL EXPOSED EDGES 1"x1" OR AS DIRECTED.  
SAFETY GRATING REQUIRED IN RESIDENTIAL AREAS ON UPSTREAM HEADWALLS

ISSUED	2010
REVISED	
SOURCE	MDSHA



DEPARTMENT OF PUBLIC WORKS

STRAIGHT HEADWALL (HORIZONTAL ELLIPTICAL CONCRETE PIPE)

STORM DRAINAGE DETAILS

STANDARD NO. D-4

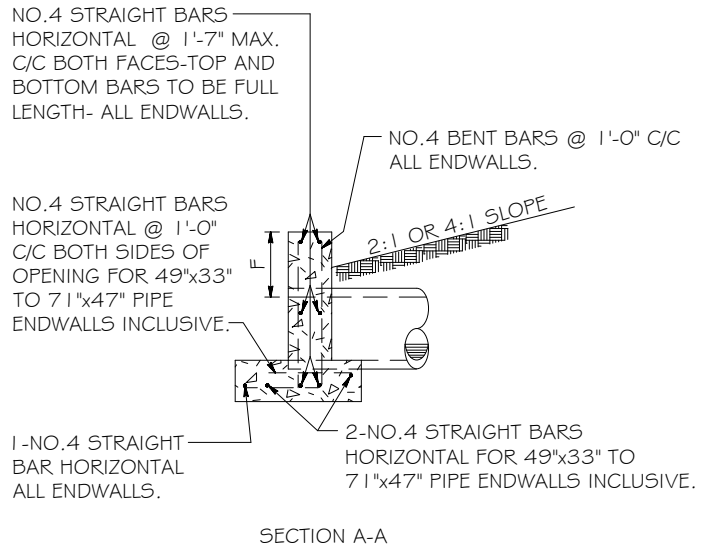
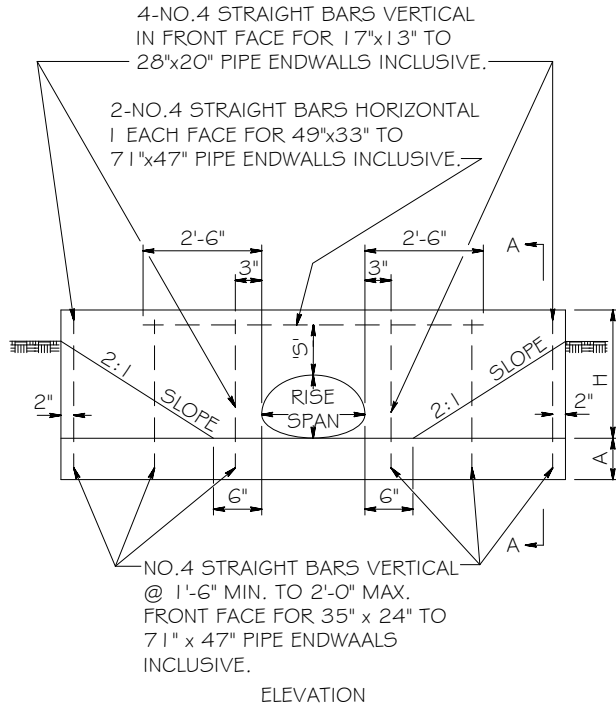
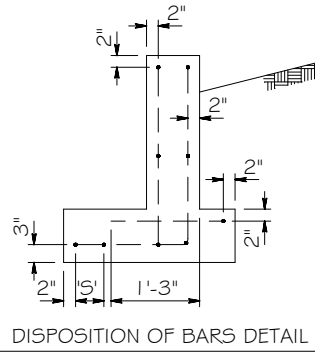
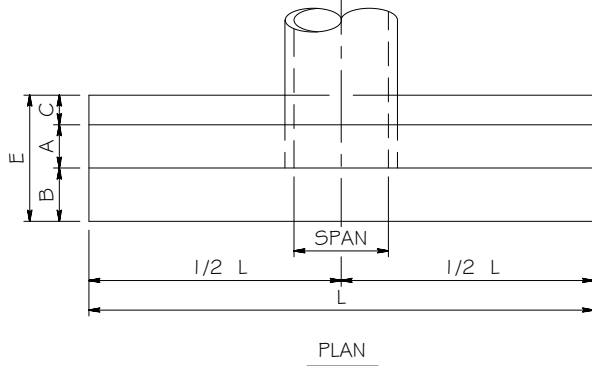

QUANTITIES FOR ESTIMATING PURPOSES ONLY

OPENING		DIMENSIONS							QUANTITIES	
D	AREA	A	B	C	E	F	H	L	CONC.	STEEL
INCHES SXR	SQ. FT.								C.Y.	lbs.
17X13	1.23	9"	6"	6"	1'-9"	9"	1'-10"	6'-3"	0.54	38
21X15	1.77	9"	6"	6"	1'-9"	9"	2'-0"	9'-6"	0.98	56
24X18	2.40	9"	6"	6"	1'-9"	9"	2'-3"	9'-6"	0.96	55
28X20	3.14	9"	6"	6"	1'-9"	9"	2'-5"	9'-6"	0.96	55
35X24	4.91	9"	14"	6"	2'-5"	12"	2'-9"	13'-8"	1.98	96
42X29	7.07	9"	14"	6"	2'-5"	12"	3'-2"	13'-8"	1.92	95
49X33	9.62	12"	16"	10"	3'-2"	12"	3'-9"	17'-11"	4.34	186
57X38	12.57	12"	16"	10"	3'-2"	12"	4'-2"	17'-11"	4.73	186
64X43	15.90	12"	20"	12"	3'-8"	12"	4'-7"	21'-9"	6.27	243
71X47	19.64	12"	20"	12"	3'-8"	12"	4'-11"	21'-9"	6.05	243

'S' DISTANCES

- 4" FOR 17" x 13" TO 24" x 18" INCLUSIVE.
- 6" FOR 28" x 20" TO 42" x 29" INCLUSIVE.
- 8" FOR 49" x 33" TO 71" x 47" INCLUSIVE.

GENERAL NOTES

- SPECIFICATIONS: LATEST TOWN OF SMYRNA
- CONCRETE SHALL BE CLASS B
- REINFORCING: DEFORMED STEEL BARS NO.4
- CHAMFER: ALL EXPOSED EDGES 1"x1" OR AS DIRECTED.
- SAFETY GRATING REQUIRED IN RESIDENTIAL AREAS ON UPSTREAM HEADWALLS

ISSUED	2010
REVISED	
SOURCE	MDSHA



DEPARTMENT OF PUBLIC WORKS

# STRAIGHT HEADWALL (METAL ARCH PIPE)

STORM DRAINAGE DETAILS

STANDARD NO. D-5

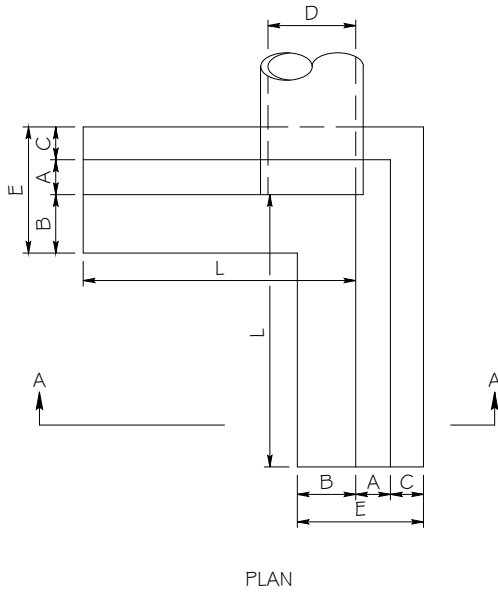

PLAN

QUANTITIES FOR ESTIMATING PURPOSES ONLY

OPENING		DIMENSIONS						QUANTITIES	
D	AREA	A	B	C	E	H	L	CONC. C.Y.	STEEL LBS.
INCHES	SQ.FT								
12	0.79	9"	6"	6"	1'-9"	1'-9"	3'-6"	0.76	55
15	1.23	9"	6"	6"	1'-9"	2'-0"	4'-3"	0.99	61
18	1.77	9"	6"	6"	1'-9"	2'-3"	5'-0"	1.17	68
21	2.40	9"	6"	6"	1'-9"	2'-6"	5'-9"	1.38	77
24	3.14	9"	14"	6"	2'-5"	2'-9"	6'-6"	1.84	106
27	3.98	9"	14"	6"	2'-5"	3'-0"	7'-3"	2.11	115
30	4.91	9"	14"	6"	2'-5"	3'-6"	8'-0"	2.57	140
33	5.94	9"	14"	6"	2'-5"	3'-9"	8'-9"	2.92	148
36	7.07	12"	16"	10"	3'-2"	4'-0"	9'-6"	4.99	235
42	9.62	12"	16"	10"	3'-2"	4'-6"	11'-0"	6.12	303
48	12.57	12"	16"	10"	3'-2"	5'-0"	12'-6"	7.34	341
54	15.90	12"	20"	12"	3'-8"	5'-6"	14'-0"	9.17	438
60	19.64	12"	20"	12"	3'-8"	6'-0"	15'-6"	10.86	496
72	28.27	12"	20"	12"	3'-8"	7'-0"	17'-0"	12.69	597

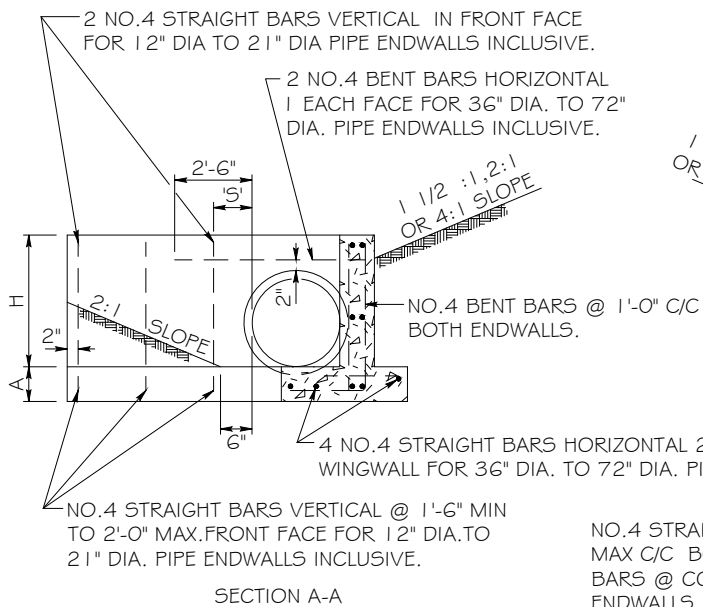

SECTION A-A

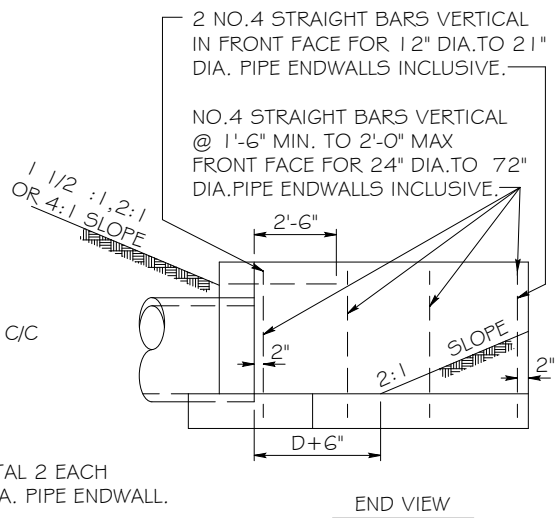

END VIEW

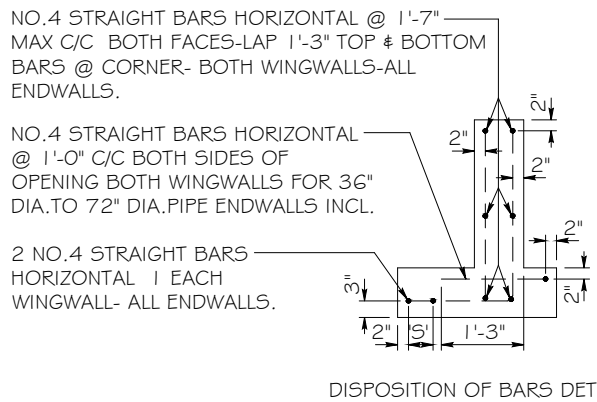

DISPOSITION OF BARS DETAIL

'S' DISTANCES  
 4" FOR 12" DIA. TO 21" DIA. PIPES INCLUSIVE.  
 6" FOR 24" DIA. TO 36" DIA. PIPES INCLUSIVE.  
 8" FOR 42" DIA. TO 72" DIA. PIPES INCLUSIVE.

GENERAL NOTES  
 SPECIFICATIONS: LATEST TOWN OF SMYRNA  
 CONCRETE SHALL BE CLASS B  
 REINFORCING: DEFORMED STEEL BARS - NO.4  
 CHAMFER: ALL EXPOSED EDGES 1"x 1" OR AS DIRECTED.  
 SAFETY GRATING REQUIRED IN RESIDENTIAL AREAS ON UPSTREAM HEADWALLS

ISSUED	2010		"L" HEADWALL
REVISED			
SOURCE	MDSHA	DEPARTMENT OF PUBLIC WORKS	STORM DRAINAGE DETAILS
			STANDARD NO. D-6



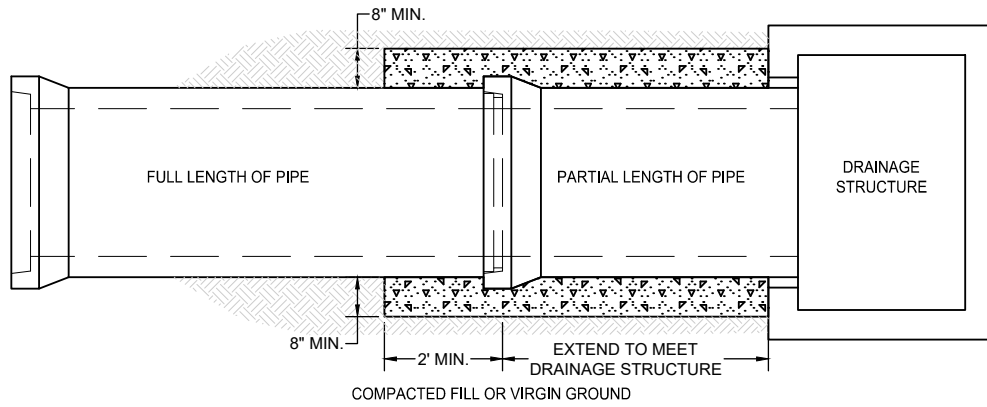

PLAN VIEW

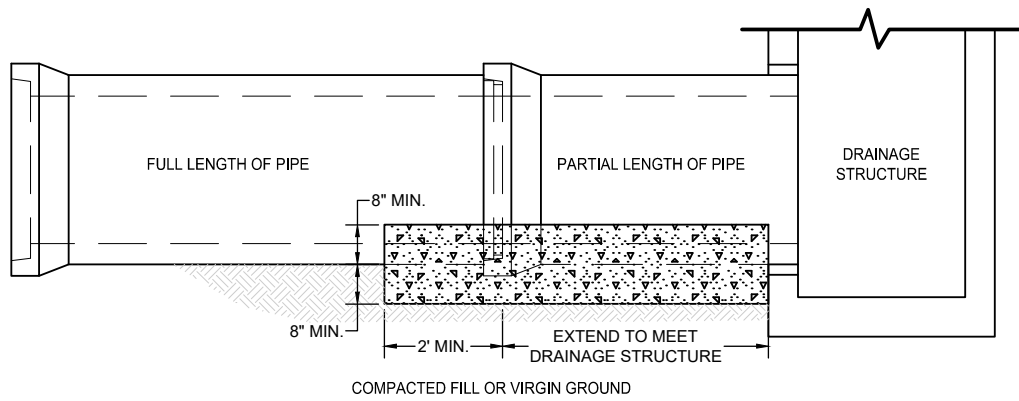

PROFILE VIEW

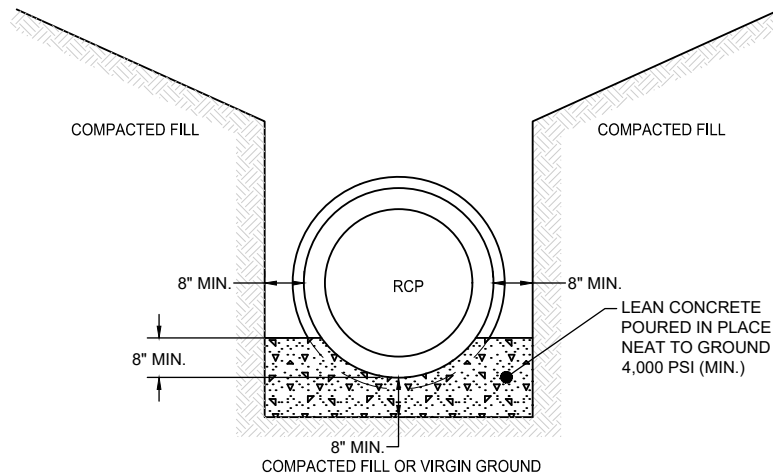

SECTION VIEW

ISSUED	2021
REVISED	
SOURCE	MDSHA



DEPARTMENT OF  
PUBLIC WORKS

## PARTIAL PIPE CRADLE

STORM DRAINAGE DETAILS

STANDARD NO. D-8



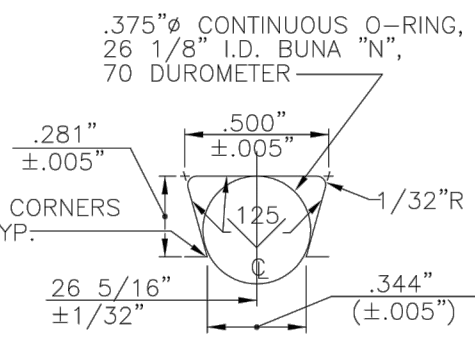
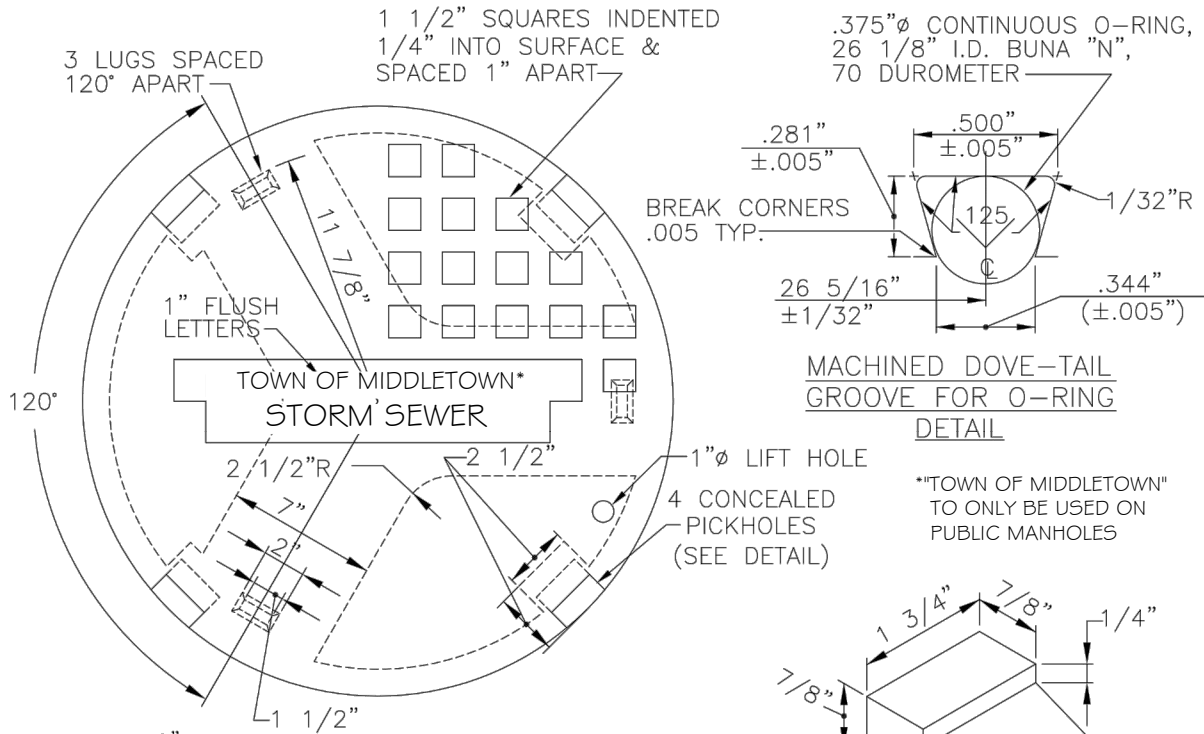

MACHINED DOVE-TAIL GROOVE FOR O-RING DETAIL

\*"TOWN OF MIDDLETOWN" TO ONLY BE USED ON PUBLIC MANHOLES

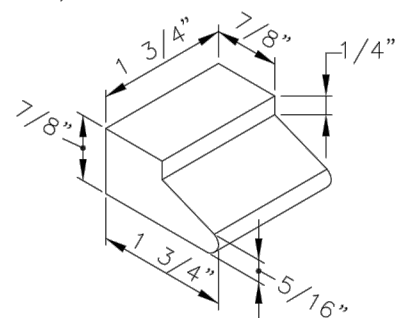

CONCEALED PICKHOLE DETAIL

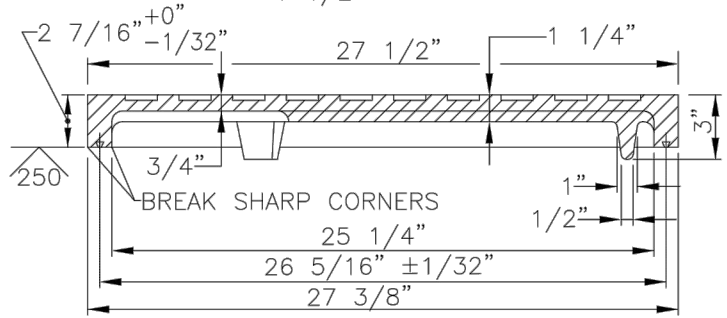

MANHOLE COVER

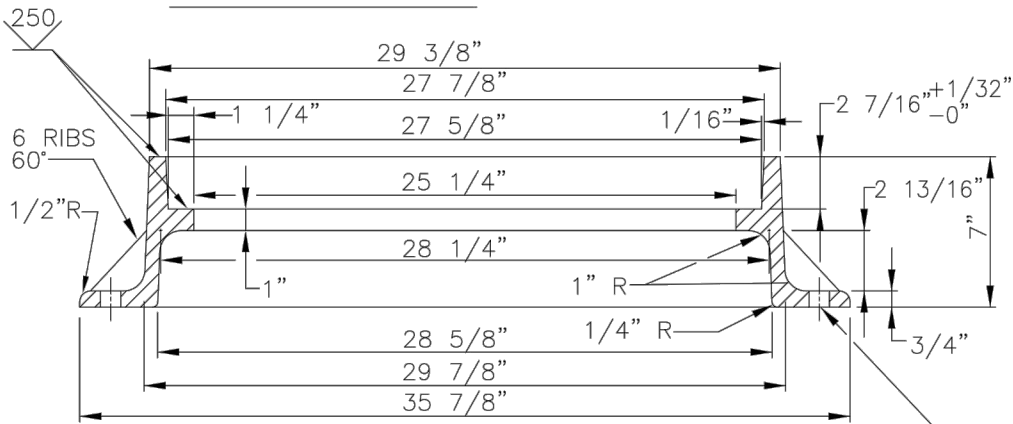

MANHOLE FRAME

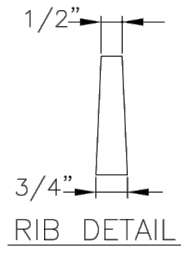

RIB DETAIL

MATERIAL:  
GRAY IRON ASTM A48, CLASS 35.

TOLERANCE:  
±1/16" EXCEPT AS NOTED.  
(FINISH MAY REQUIRE ADDITIONAL MACHINING)

(4) 2" (51mm) x 7/8" (32mm) SLOTTED HOLES ON 33" (833mm) DIA BOLT CIRCLE

ISSUED	2021
REVISED	
SOURCE	MDSHA



DEPARTMENT OF PUBLIC WORKS

STANDARD MANHOLE FRAME AND COVER
STORM DRAINAGE DETAILS
STANDARD NO. D-9



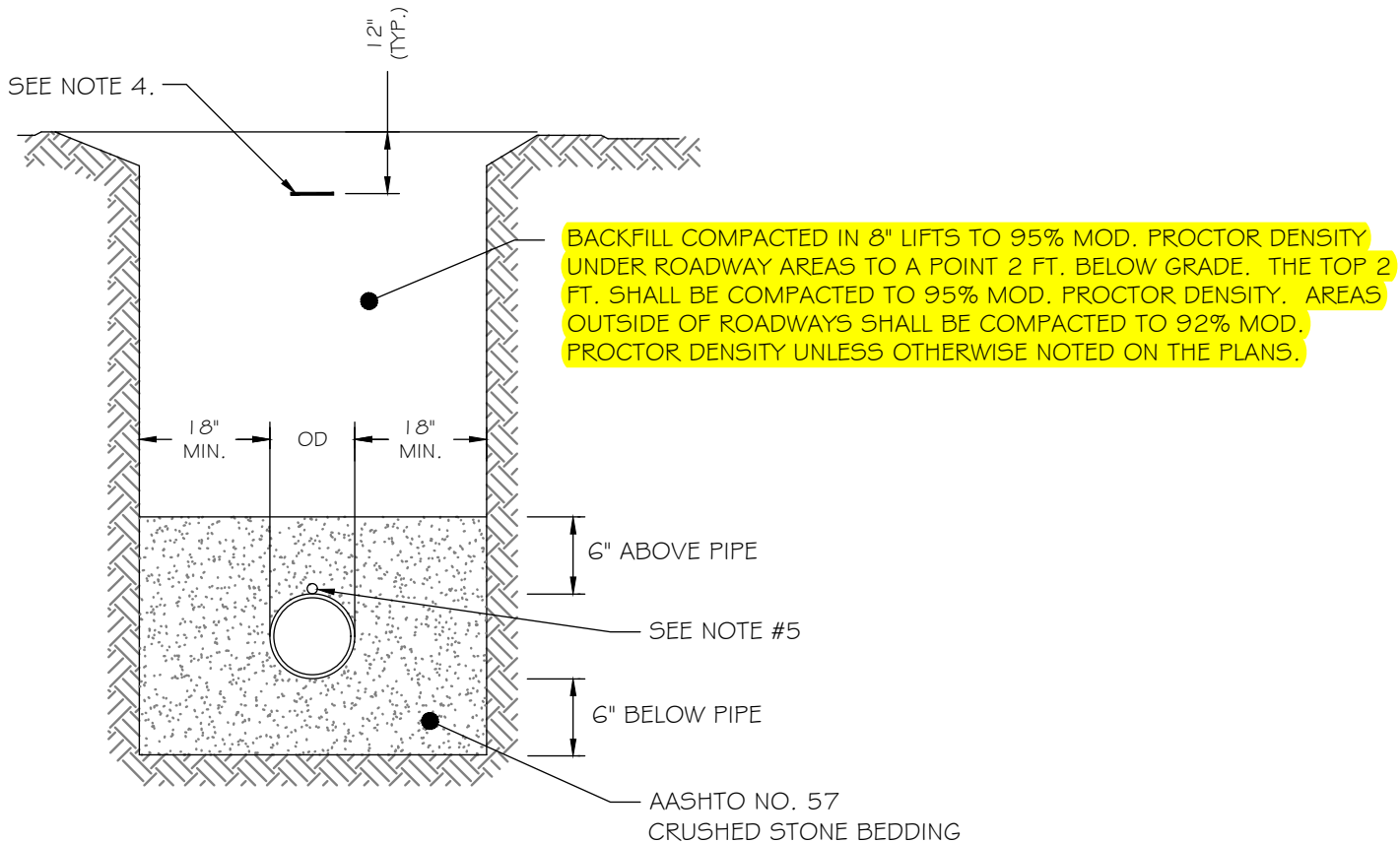

NOTES:

1. TRENCH SHALL BE BRACED OR SHEETED IN ACCORDANCE WITH OSHA REGULATIONS.
2. PROVIDE BEARING FULL LENGTH OF BARREL.
3. DIG BELL HOLES.
4. INSTALL METALLIC DETECTOR TAPE FOR GRAVITY MAINS LOCATED OUTSIDE THE ROAD RIGHT-OF-WAY AND FORCEMAINS PER SPECS AT 1' BELOW FINISHED GRADE.
5. TRACER WIRE TO BE INSTALLED ON ALL FORCEMAINS.
6. DETAIL ALSO APPLIES TO SANITARY SEWER LATERALS FROM THE MAIN TO THE CLEANOUT PROVIDED AT THE RIGHT-OF-WAY.

ISSUED	2010	 DEPARTMENT OF PUBLIC WORKS	PIPE BEDDING & TRENCH DETAIL
REVISED	2021		
			SANITARY SEWER DETAILS
SOURCE			STANDARD NO. 5-1

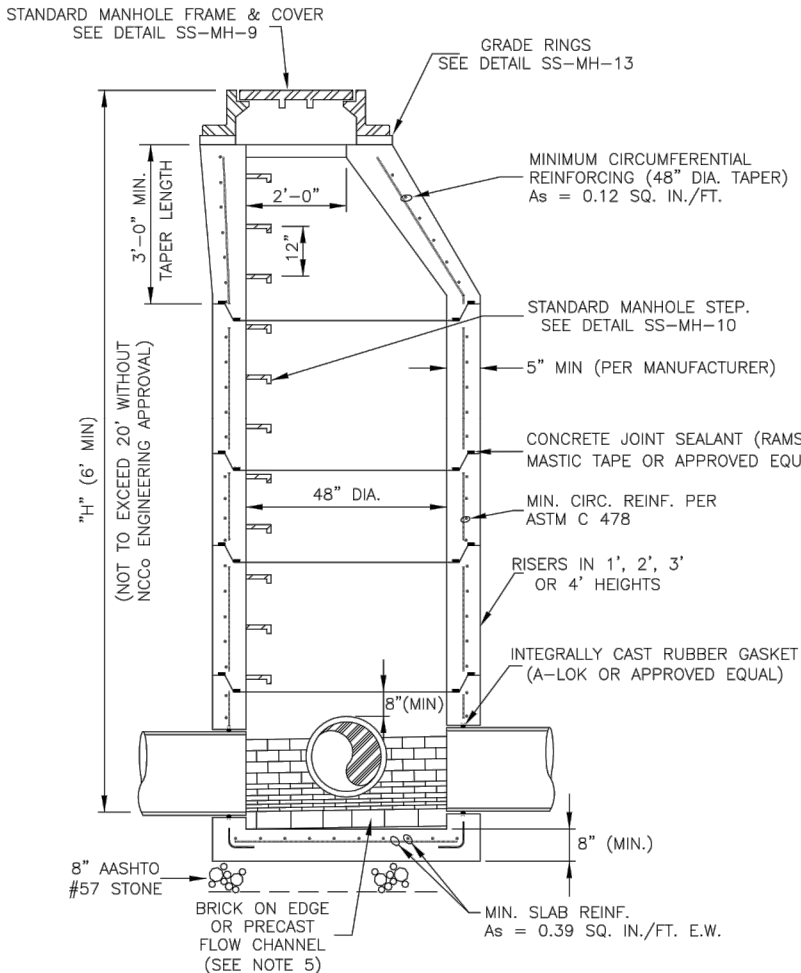

**TYPE A-2**  
**MIN 6' DEPTH**

**NOTES:**

1. UNLESS OTHERWISE NOTED, MANHOLE TAPERS, RISERS AND BASES SHALL BE FURNISHED IN STRICT ACCORDANCE WITH ASTM DESIGNATION C478 (OR LATEST) FOR PRECAST REINFORCED CONCRETE MANHOLES.
2. ALL MANHOLES SHALL BE 4,000 PSI MIN. CONCRETE.
3. REINFORCING FOR TYPE A-3 MANHOLE SAME AS TYPE A-2 MANHOLE, EXCEPT AS NOTED.
4. MANHOLE STEPS SHALL BE SPACED AS SHOWN IN A SINGLE VERTICAL ALIGNMENT. THE STEPS SHALL NOT BE STAGGERED. CENTERLINE OF STEP ORIENTATION TO BE ALIGNED OVER TOP OF BENCH AND NOT FLOW CHANNEL. BOTTOM STEP SHALL BE WITHIN 12" OF THE BENCH.
5. FLOW CHANNEL IN MANHOLE MAY BE BRICK ON EDGE OR PRECAST CONCRETE (4,000 PSI MIN.) NO CAST IN PLACE FLOW CHANNELS. SLOPE OF BENCH TO BE 1/4"/FT. MIN. TOWARD CHANNEL.
6. SLOPE ACROSS MANHOLE CHANNEL TO BE 0.1' MIN.

7. THE TOWN REQUIRES ALL PUBLIC MANHOLES TO BE A MINIMUM 60" DIAMETER.

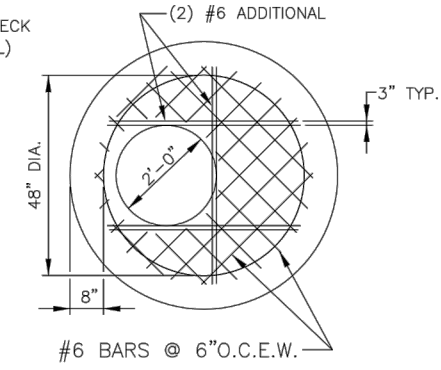

**SLAB REINFORCEMENT**  
**FOR SHALLOW TYPE A-3**  
**PRECAST MANHOLE**

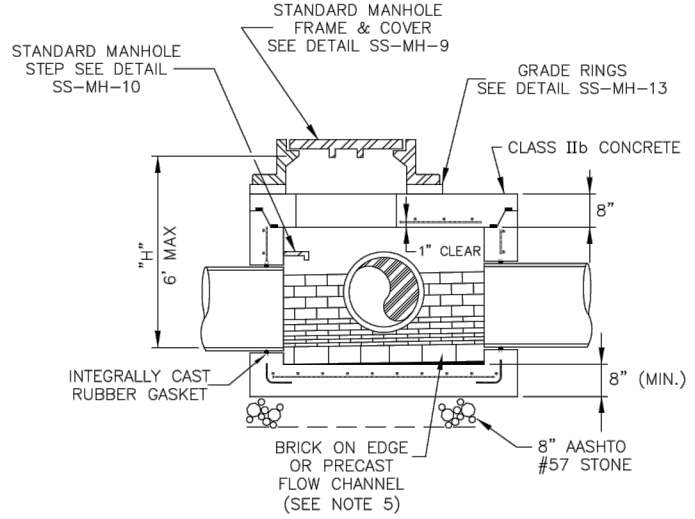

**SHALLOW TYPE A-3**  
**MAX 6' DEPTH**

ISSUED	2010
REVISED	2021
SOURCE	

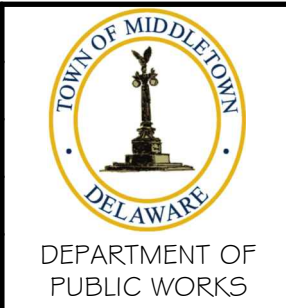

**STANDARD 48" PRECAST CONCRETE**  
**MANHOLE (PRIVATE)**

SANITARY SEWER DETAILS

STANDARD NO. S-2

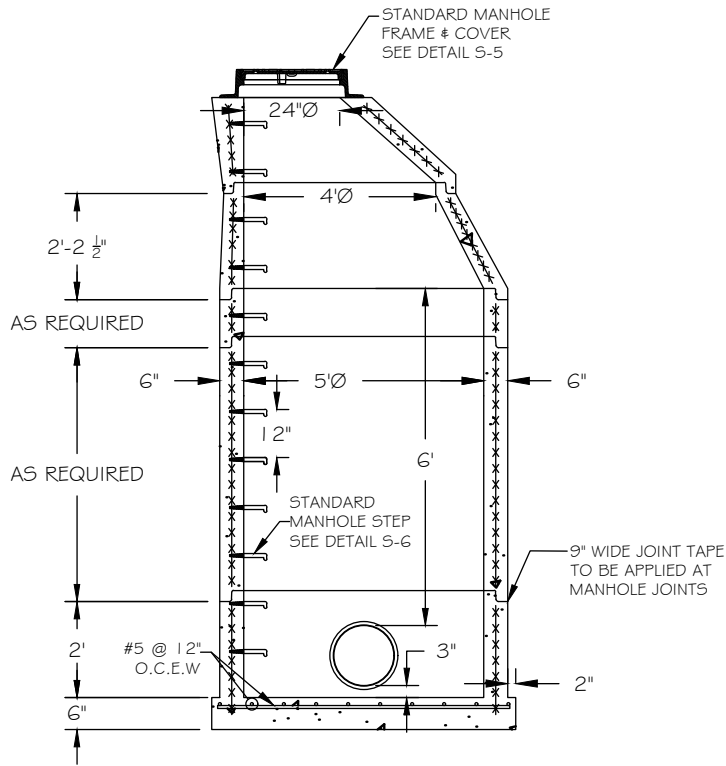

**TYPE A-2  
MIN 6' DEPTH**

**NOTES:**

1. UNLESS OTHERWISE NOTED, RISERS AND BASES SHALL BE FURNISHED IN STRICT ACCORDANCE WITH ASTM DESIGNATION C478 (OR LATEST) FOR PRECAST CONCRETE MANHOLES.
2. MANHOLE IS MANUFACTURED I.A.W. ASTM C-478  $F_c=4500$  PSI @ 28 DAYS.
3. REINFORCING: ASTM A-185 AREA 0.15 IN<sup>2</sup>/VERTICAL FOOT.
4. REINFORCING FOR TYPE A-3 MANHOLE SAME AS TYPE A-2 MANHOLE, EXCEPT AS NOTED.
5. MANHOLE STEPS SHALL BE SPACED AS SHOWN IN A SINGLE VERTICAL ALIGNMENT, THE STEPS SHALL NOT BE STAGGERED. CENTERLINE OF STEP ORIENTATION TO BE ALIGNED OVER TOP OF BENCH AND NOT FLOW CHANNEL. BOTTOM STEP SHALL BE 12" OF THE BENCH..
6. FLOW CHANNEL IN MANHOLE MAY BE BRICK ON EDGE OR PRECAST CONCRETE. NO CAST IN PLACE FLOW CHANNEL. SLOPE OF BENCH TO BE 1/4" / FT. MIN TOWARD CHANNEL.
7. DROP ACROSS MANHOLE CHANNEL TO BE 0.1' MIN.
8. MANHOLE JOINTS TO BE SEALED CONSEAL CS-102
9. PIPE TO MANHOLE SEAT TO BE STAR SEAL GASKETS

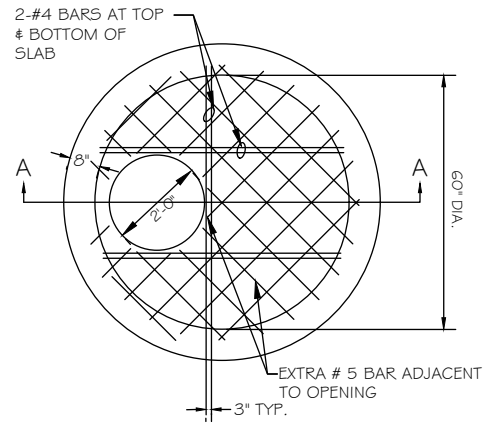

**SLAB REINFORCEMENT  
FOR SHALLOW TYPE A-3  
PRECAST MANHOLE**

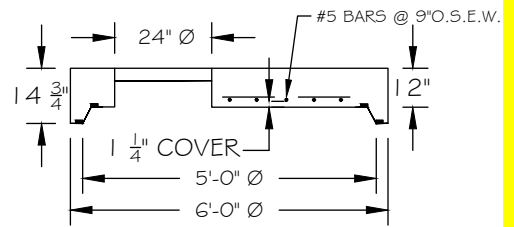

**SLAB TOP - 24" OPENING  
SECTION VIEW A-A**

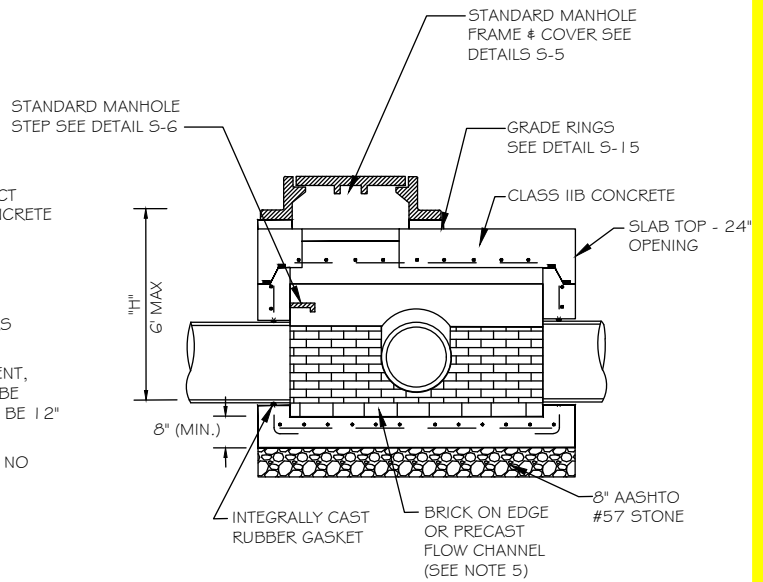

**SHALLOW TYPE A-3  
MAX 6' DEPTH**

ISSUED	2010
REVISED	2021
SOURCE	NEW CASTLE COUNTY



DEPARTMENT OF  
PUBLIC WORKS

**STANDARD 60" PRECAST CONCRETE  
MANHOLE**

SANITARY SEWER DETAILS

STANDARD NO. S-3

NOTES:

1. ONLY ONE INSIDE DROP CONNECTION PER MANHOLE WILL BE ALLOWED, UNLESS APPROVED BY THE TOWN.
2. THE DROP FITTING SHALL NOT EXTEND INTO THE AREA THAT IS DEFINED BY THE PROJECTION OF THE MANHOLE ENTRANCE VERTICALLY DOWN TO THE MANHOLE BOTTOM. IF NECESSARY, MANHOLE FRAME, COVER, CONE SECTION, AND STEPS SHALL BE REMOVED AND PLACED TO ALLOW FOR UNOBSTRUCTED ENTRY AND EXIT.
3. INFLUENT PIPE SLOPE SHALL NOT EXCEED 5%.
4. MAXIMUM SIZE OF INFLUENT PIPE IS 8".
5. PROPOSED MANHOLE WITH INSIDE DROP MUST BE A MIN. OF 5' IN DIAMETER. INSIDE DROPS PROPOSED AT AN EXISTING MANHOLE OF LESS THAN 5' DIAMETER WILL BE REVIEWED ON A CASE BY CASE BASIS.

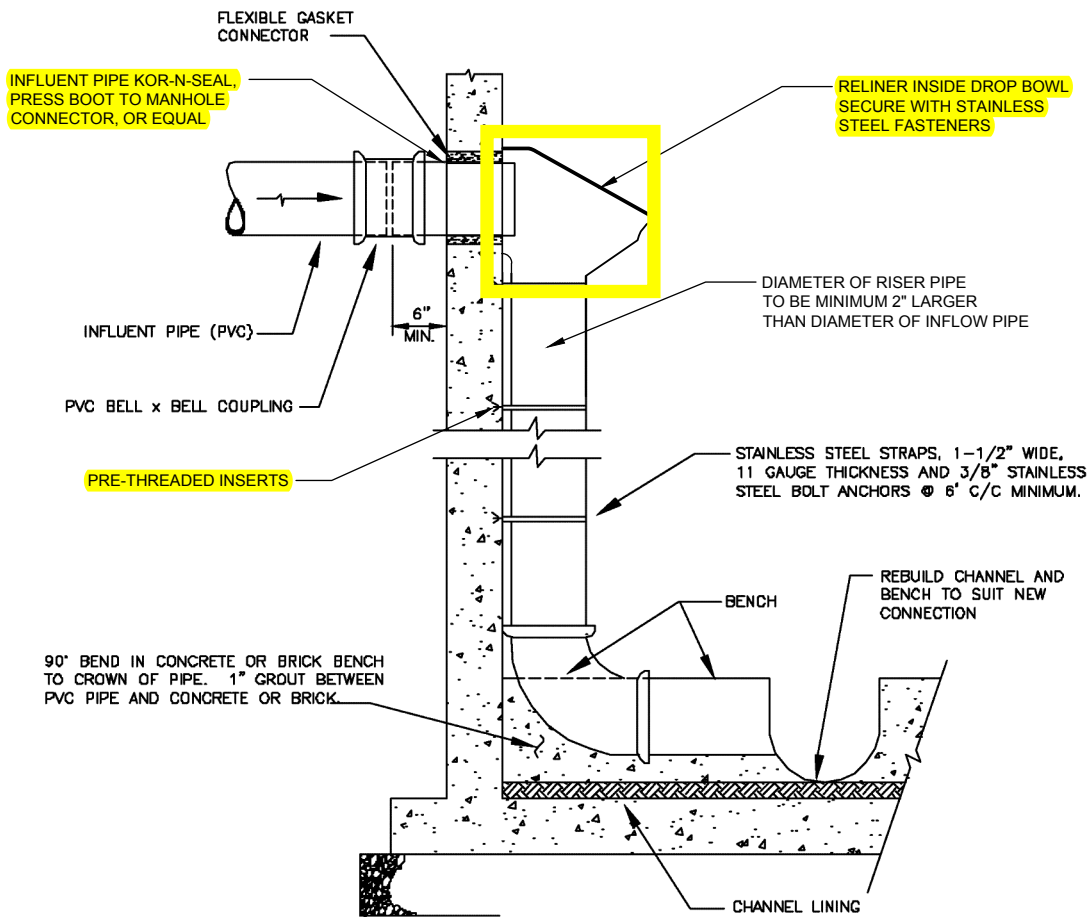

ISSUED	2010	 DEPARTMENT OF PUBLIC WORKS	INSIDE DROP MANHOLE CONNECTION
REVISED	2021		
			STANDARD NO. S-4
SOURCE			

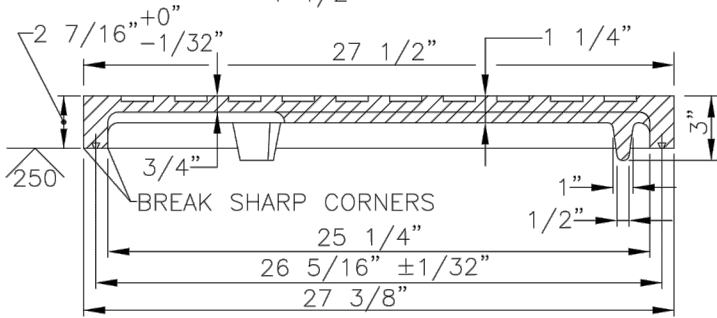
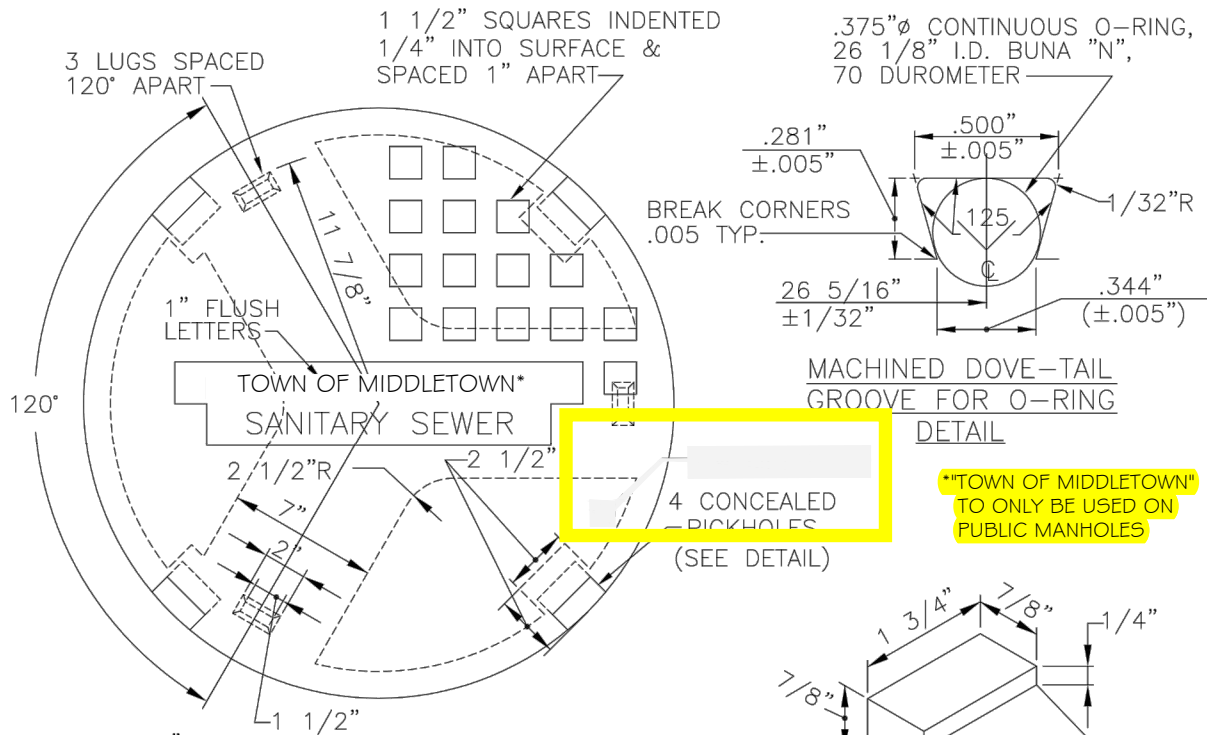

MANHOLE COVER

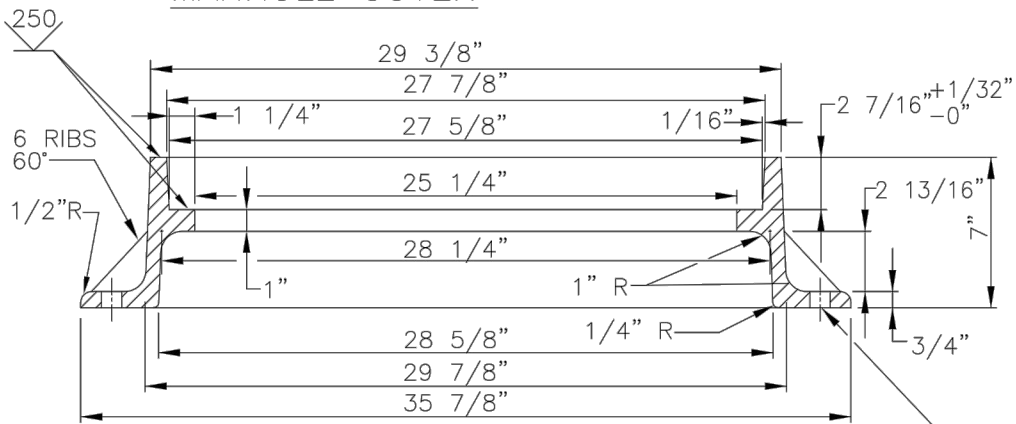
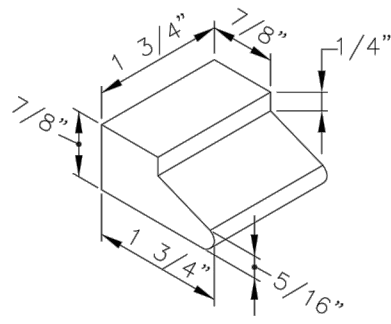

MANHOLE FRAME

(4) 2" (51mm) x 7/8" (32mm)  
SLOTTED HOLES ON 33"  
(833mm) DIA BOLT CIRCLE

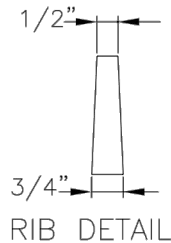

ISSUED	2010
REVISED	2021
SOURCE	NEW CASTLE COUNTY



DEPARTMENT OF  
PUBLIC WORKS

STANDARD MANHOLE FRAME AND COVER

SANITARY SEWER DETAILS

STANDARD NO. S-5

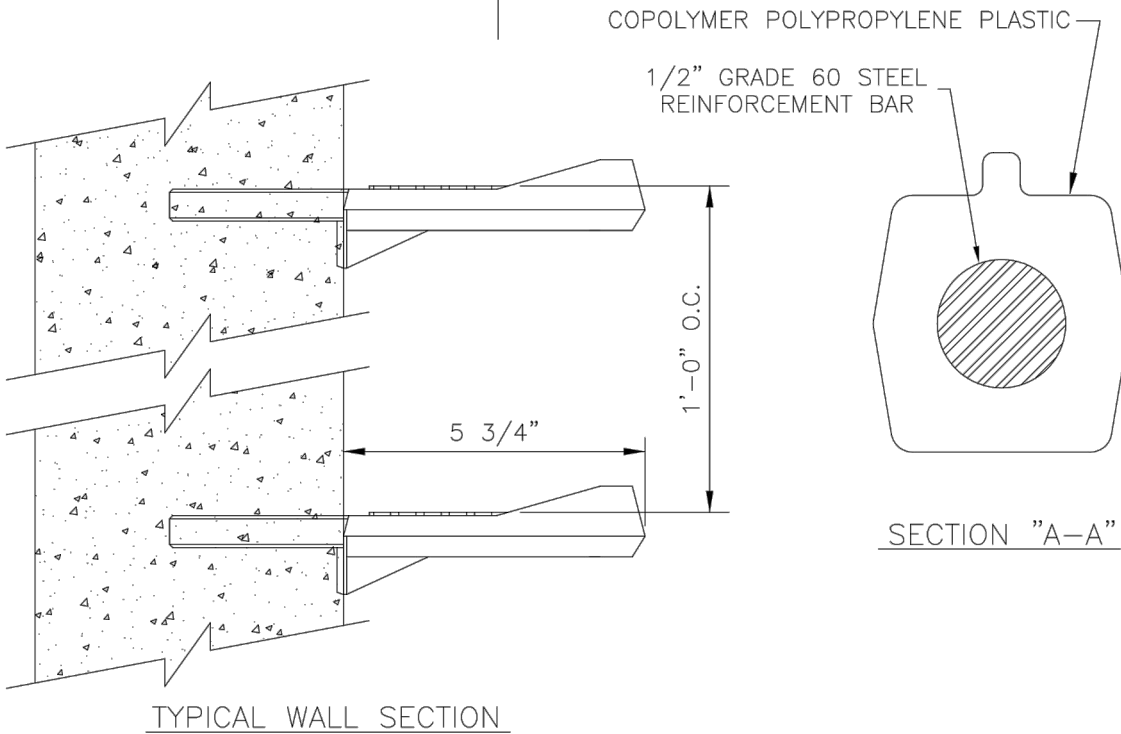
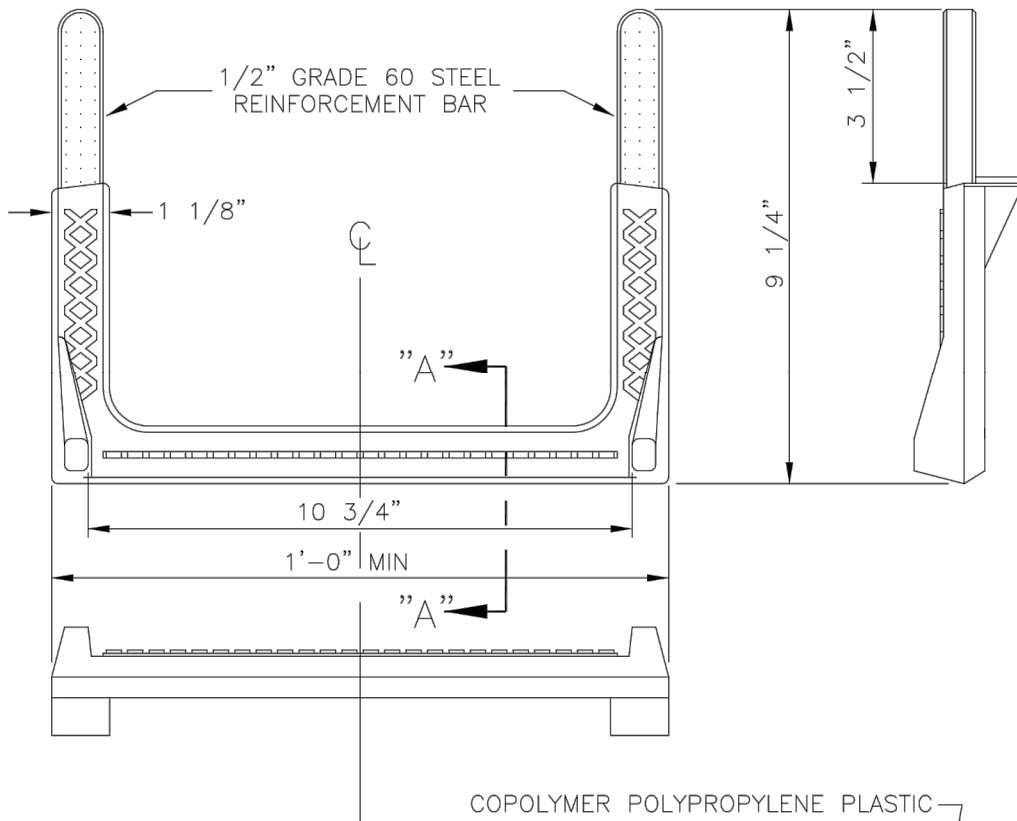

ISSUED	2010
REVISED	
SOURCE	NEW CASTLE COUNTY

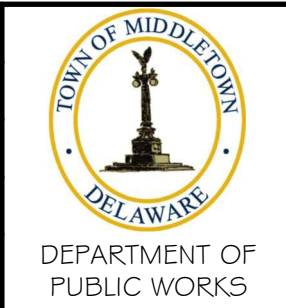

SANITARY SEWER MANHOLE STEPS	
SANITARY SEWER DETAILS	
STANDARD NO. S-6	

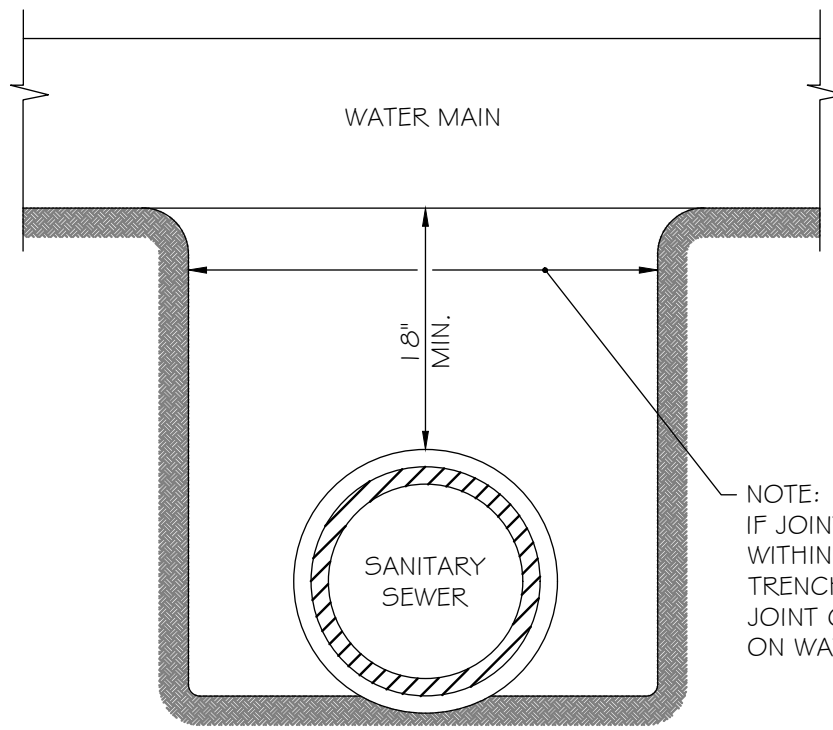

NOTE:  
 IF JOINT ON WATER MAIN IS WITHIN LIMITS OF SEWER TRENCH, MECHANICAL BELL JOINT CLAMP WILL BE PROVIDED ON WATER MAIN JOINT.

- NOTE:
1. HORIZONTAL AND VERTICAL CLEARANCE BETWEEN WATER AND SANITARY SEWER MAINS SHALL BE PER TEN STATES STANDARDS.
  2. CROSSINGS OF WATER AND SANITARY SEWER WITH LESS THAN 18" OF CLEARANCE SHALL REQUIRE OFFICE OF DRINKING WATER APPROVAL.

ISSUED	2010		WATER MAIN CLEARANCE	
REVISED	2021			SANITARY SEWER DETAILS
SOURCE			DEPARTMENT OF PUBLIC WORKS	STANDARD NO. S-7

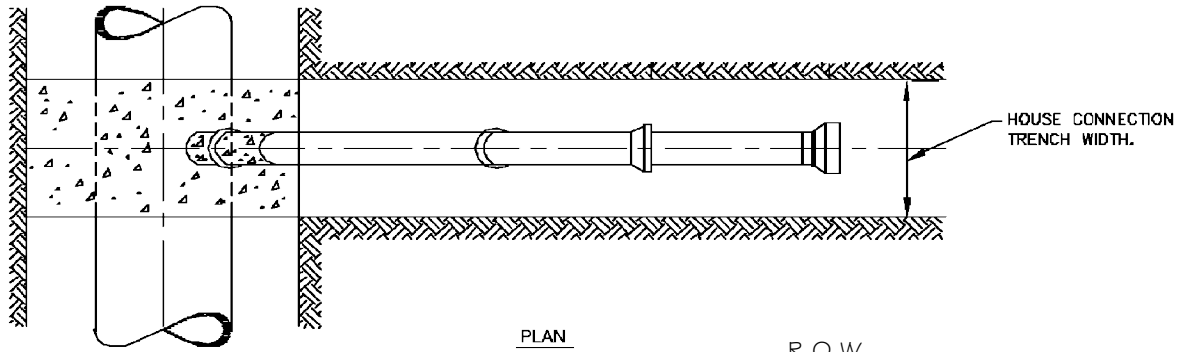

PLAN

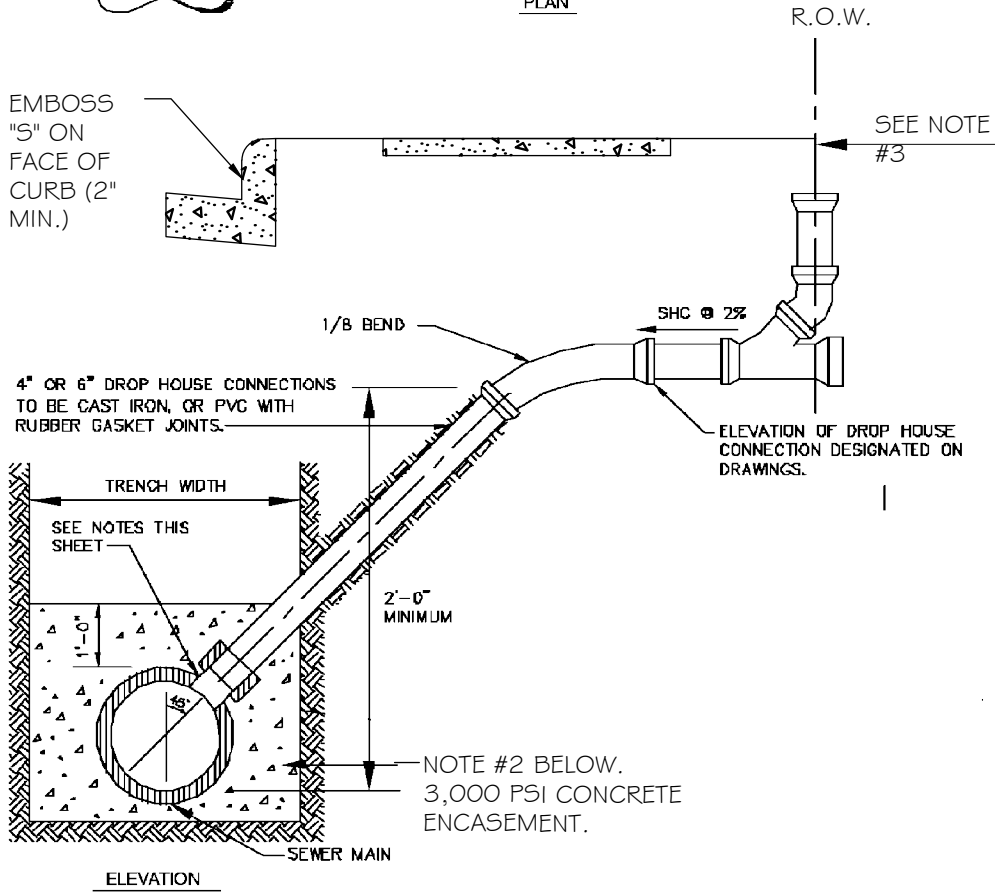

ELEVATION

NOTES:

1. S.H.C. TO NEW MAIN USES STANDARD "Y" BRANCH.
2. S.H.C. TO EXISTING MAIN USES COUPLING.
3. CLEAN OUT TO BE LOCATED AT RIGHT-OF-WAY/PROPERTY LINE.

ISSUED	2010		<p>4" AND 6" DROP HOUSE CONNECTION (NEW CONSTRUCTION)</p>
REVISED			
			<p>SANITARY SEWER DETAILS</p>
SOURCE			<p>DEPARTMENT OF PUBLIC WORKS</p>



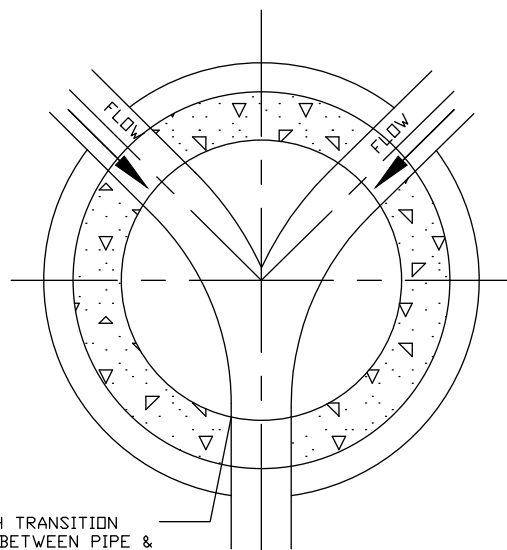
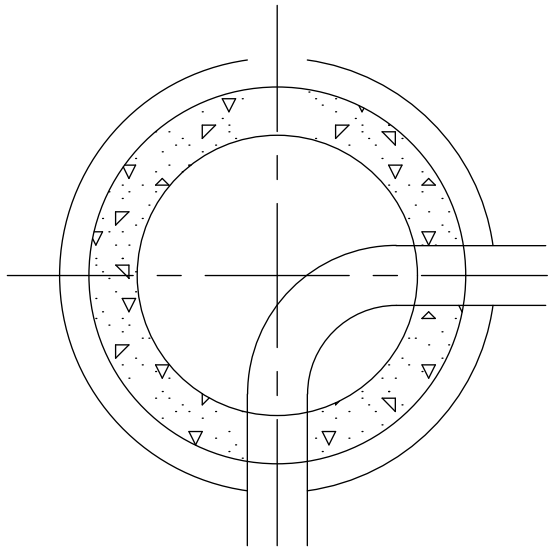

SMOOTH TRANSITION  
REQUIRED BETWEEN PIPE &  
CHANNEL (TYPICAL)

CHANNEL LINING NOTES:

1. CHANNEL LINING SHALL BE CONCRETE. MINIMUM 4" THICK.
2. WIDTH OF CHANNEL SHALL MATCH INSIDE DIAMETER OF INCOMING AND OUTGOING PIPES. BLEND CHANNEL LINING FOR SMOOTH CONTOUR BETWEEN PIPES.
3. CONCRETE CHANNELS SHALL BE FORMED AS SHOWN.  $F'_s$  FOR CAST-IN-PLACE CHANNELS AND BENCHES SHALL BE 4000 PSI @ 28 DAYS. FOR PRECAST CHANNELS AND BENCHES,  $F'_c = 4000$  PSI MINIMUM.
4. ALL INVERT ELEVATIONS SHALL BE AS SHOWN ON THE CONTRACT DRAWINGS.

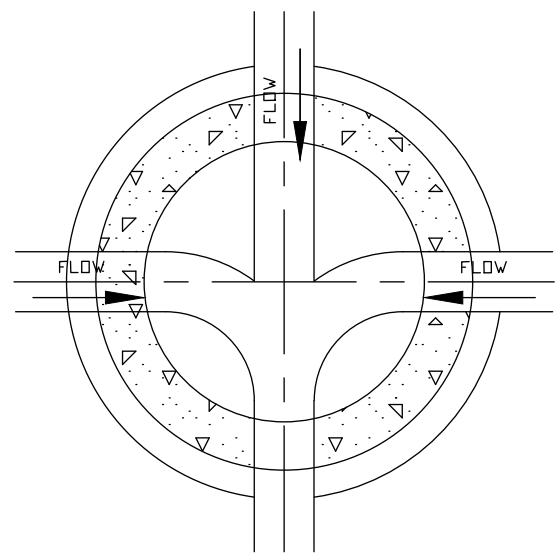

8" PVC MAIN

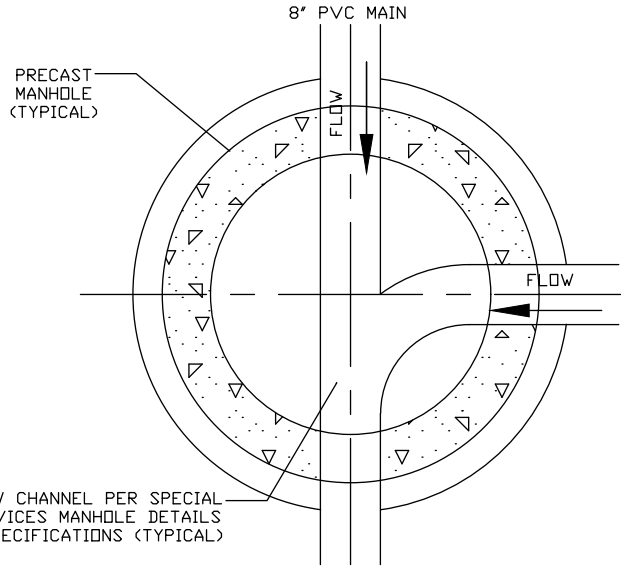

FLOW CHANNEL PER SPECIAL  
SERVICES MANHOLE DETAILS  
& SPECIFICATIONS (TYPICAL)

8" PVC MAIN

ISSUED	2010
REVISED	
SOURCE	



DEPARTMENT OF  
PUBLIC WORKS

TYPICAL CHANNELIZATION OF MAINLINE  
SEWER MANHOLES

---

SANITARY SEWER DETAILS

---

STANDARD NO. S-9

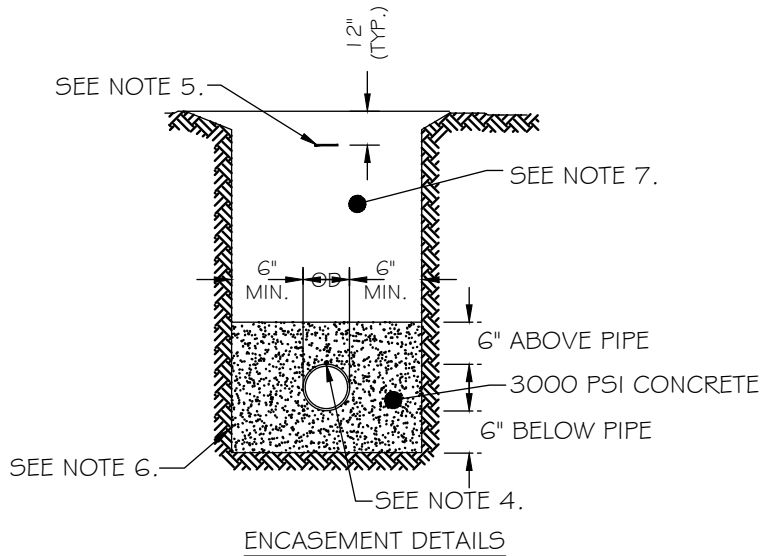

NORMAL PIPE DIAMETER	MAXIMUM PAYMENT CU. FT. PER LIN FT. CONC. ENCASEMENT
6"	1.53
8"	2.55
10"	2.95
12"	3.63
15"	4.20
18"	5.71
21"	6.35
24"	8.22
27"	8.94
30"	9.83
33"	12.16
36"	13.09
42"	15.22
48"	19.83
54"	22.97
60"	24.95
66"	27.71

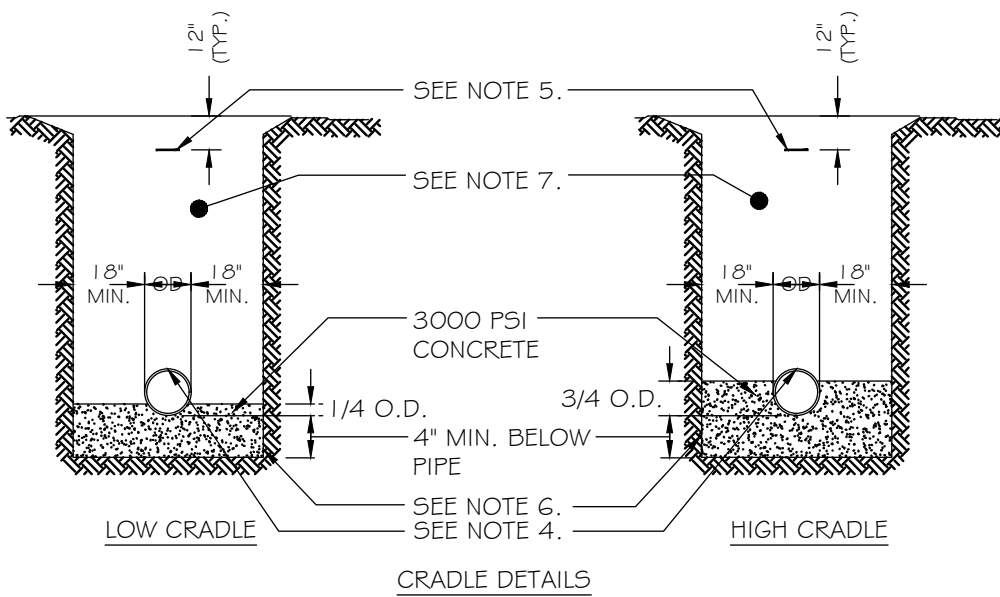

NORMAL PIPE DIAMETER	MAXIMUM PAYMENT CU. FT. PER LIN FT.	
	HIGH CRADLE	LOW CRADLE
6"	1.28	0.90
8"	1.58	1.03
10"	1.86	1.22
12"	2.33	1.51
15"	2.82	1.73
18"	4.02	2.35
21"	4.52	2.62
24"	5.95	3.34
27"	6.58	3.70
30"	7.42	4.18
33"	9.42	5.08
36"	10.53	5.65
42"	12.30	6.64
48"	16.25	8.49
54"	18.46	9.64
60"	20.80	10.95
66"	23.08	12.25

NOTES:

1. TRENCH SHALL BE BRACED OR SHEETED AS REQUIRED.
2. PROVIDE BEARING FULL LENGTH OF BARREL.
3. DIG BELL HOLES.
4. INSTALL BARE COPPER AWG #10 DETECTOR WIRE ABOVE PIPE. PROVIDE ACCESS FOR MONITORING AT 400' (MAX.) INTERVAL PER SPECS.
5. INSTALL METALLIC DETECTOR TAPE PER SPECS.
6. POUR CONCRETE AGAINST UNDISTURBED EARTH, REMOVE SHEETING BEFORE POURING CONCRETE OR LEAVE LOWER PORTION OF SHEETING IN PLACE.
7. SELECT BACKFILL MATERIAL COMPACTED IN 8" LIFTS TO 95% MOD. PROCTOR DENSITY WITHIN ROADWAY AREAS, 92% MOD. PROCTOR DENSITY OUTSIDE ROADWAY AREAS.

ISSUED	2010		CONCRETE ENCASEMENT AND CRADLE
REVISED			SANITARY SEWER DETAILS
			DEPARTMENT OF PUBLIC WORKS
SOURCE			STANDARD NO. S-10

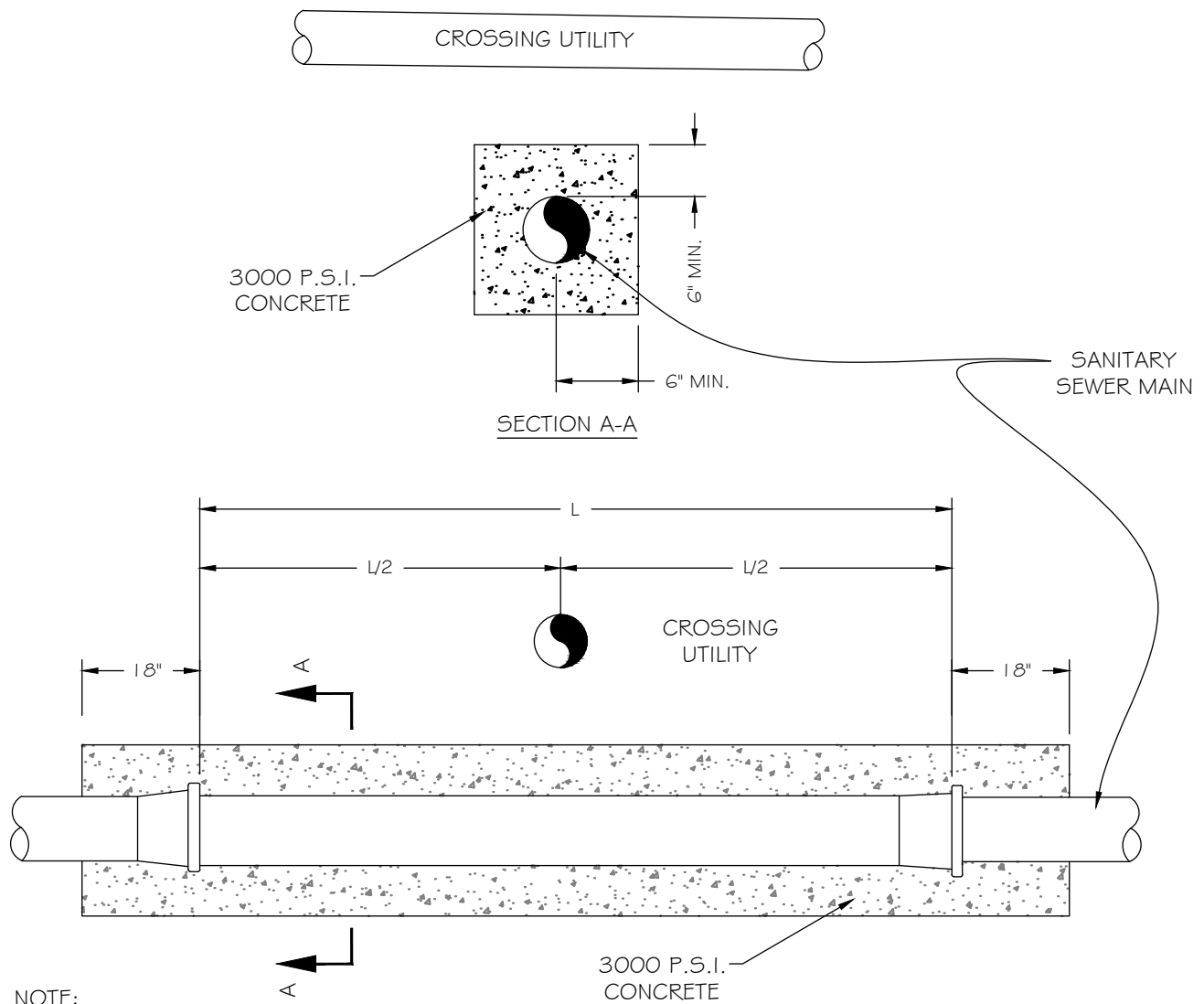

NOTE:

SANITARY SEWER MAINS SHALL BE ENCASED AS SHOWN WHEN LESS THAN 18" OF VERTICAL SEPARATION EXISTS BETWEEN THE SANITARY SEWER MAIN AND WATER MAIN AND WHEN LESS THAN 12" OF SEPARATION EXISTS BETWEEN THE SANITARY SEWER MAIN AND OTHER UTILITIES. THE ENCASEMENT LENGTH SHALL BE A MINIMUM OF TEN FEET (10') EITHER SIDE OF CROSSING UTILITY.

L = LAYING LENGTH OF SANITARY SEWER PIPE.

CONCRETE ENCASEMENT DETAIL  
N.T.S

ISSUED	2010		CONCRETE ENCASEMENT AT UTILITY CROSSINGS	
REVISED			SANITARY SEWER DETAILS	
			DEPARTMENT OF PUBLIC WORKS	STANDARD NO. S-11
SOURCE				

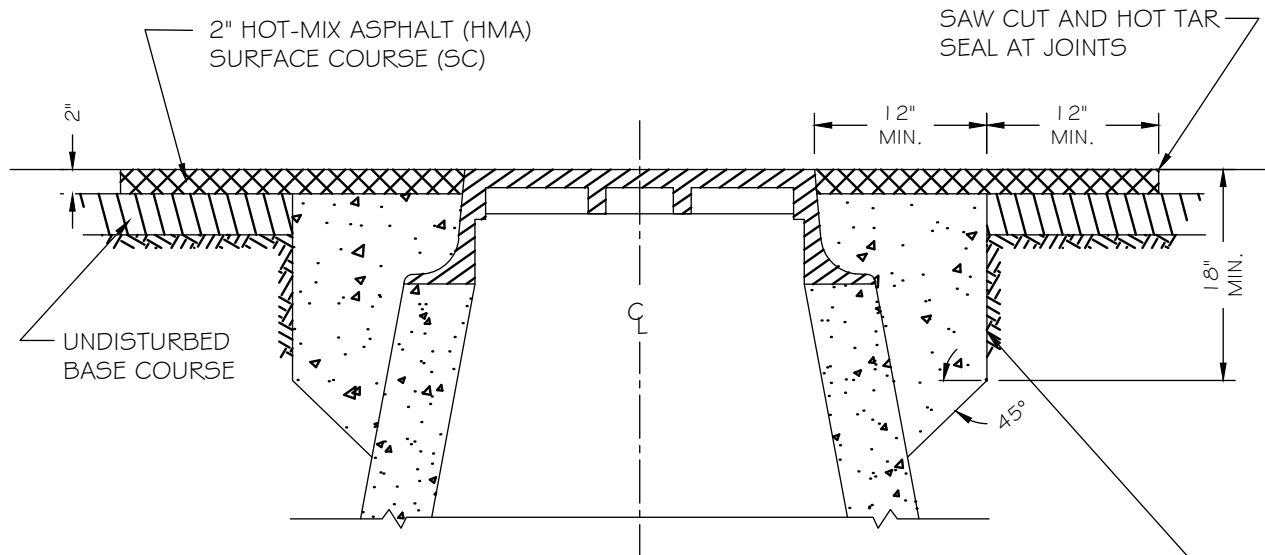

POUR 4,000 PSI  
CONCRETE COLLAR  
AGAINST UNDISTURBED  
EARTH, BASE COURSE,  
AND EXTEND TO FRAME  
UP TO 2" BELOW  
SURFACE OF FINISHED  
PAVEMENT

NOTES:

1. USE MIN. 4,000 PSI PORTLAND CEMENT CONCRETE.
2. FOR NEW INSTALLATION USE FORMWORK. DO NOT REMOVE FORMS FOR A MIN. OF 24 HOURS AFTER POUR. COMPACT FILL AROUND COLLAR AFTER 48 HOURS. PAVEMENT MAY BE PLACED AFTER 72 HOURS.
3. DO NOT ALLOW TRAFFIC ON CONCRETE FOR 48 HOURS UNLESS HIGH EARLY ADDITIVE IS USED.

ISSUED	2010		CONCRETE MANHOLE COLLAR (PAVED AREAS)	
REVISED	2021			SANITARY SEWER DETAILS
			DEPARTMENT OF PUBLIC WORKS	STANDARD NO. 5-12
SOURCE				

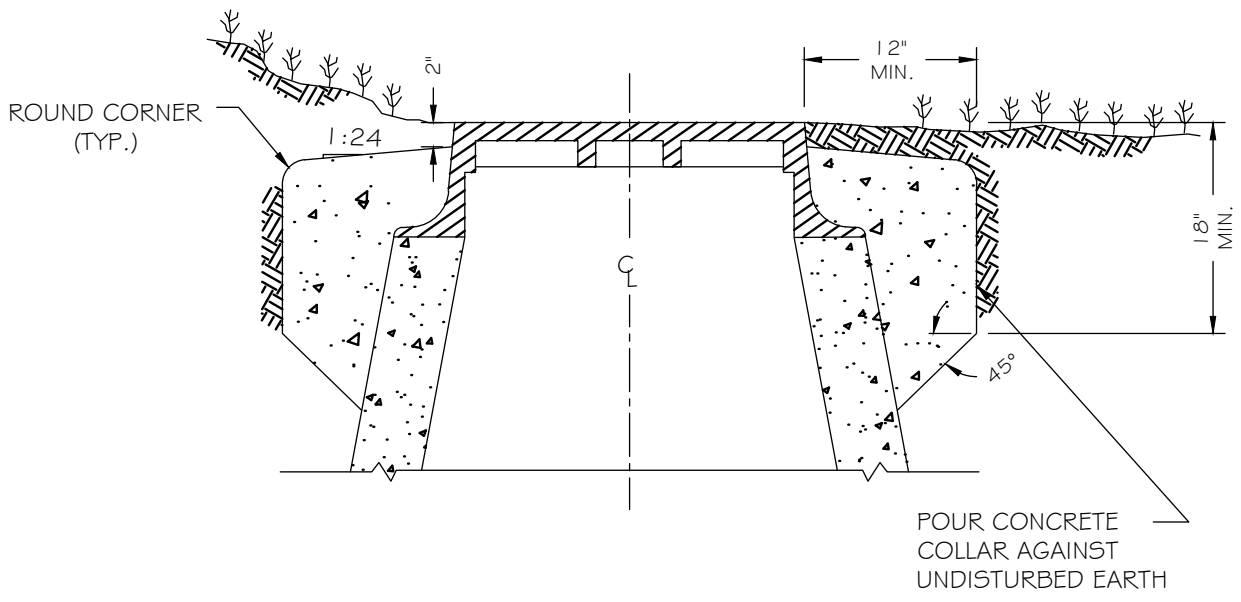

NOTES:

1. USE 3000 LB MIX PORTLAND CEMENT CONCRETE.
2. FOR NEW INSTALLATION USE FORMWORK. DO NOT REMOVE FORMS FOR A MIN. OF 24 HOURS AFTER POUR. COMPACT FILL AROUND COLLAR AFTER 48 HOURS. PAVEMENT MAY BE PLACED AFTER 72 HOURS.
3. TOP SOIL, SEED AND MULCH ENTIRE DISTURBED AREA.

ISSUED	2010		CONCRETE MANHOLE COLLAR (NON-PAVED AREAS)	
REVISED			SANITARY SEWER DETAILS	
			DEPARTMENT OF PUBLIC WORKS	STANDARD NO. S-13
SOURCE				

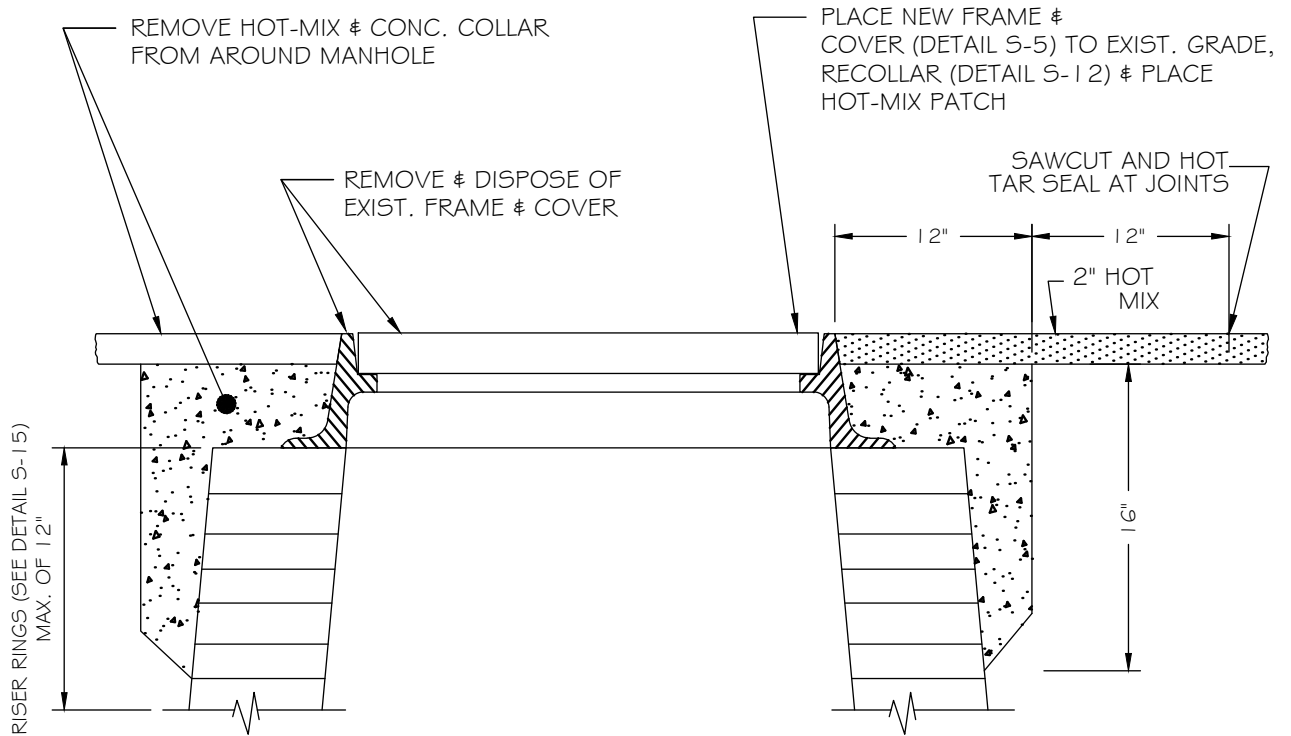

ISSUED	2010
REVISED	
SOURCE	



DEPARTMENT OF  
PUBLIC WORKS

## MANHOLE FRAME REPLACEMENT

SANITARY SEWER DETAILS

STANDARD NO. S-14

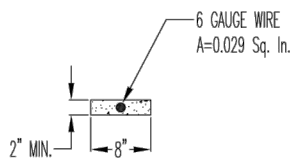
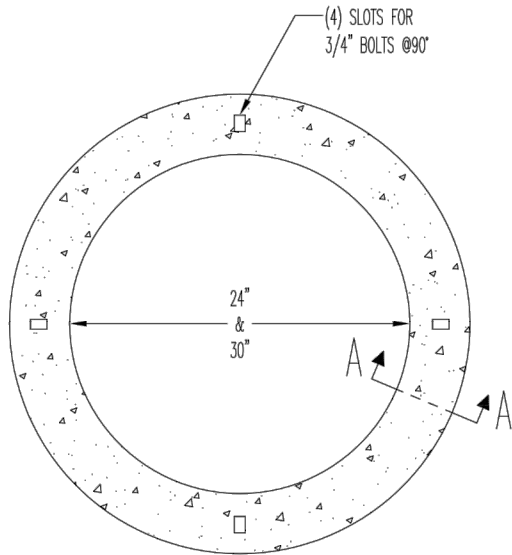

SECTION A-A

## REINFORCED CONCRETE RISER

### NOTES:

1. CONCRETE SHOULD ATTAIN A COMPRESSIVE STRENGTH OF 4,000 psi IN 28 DAYS.
2. DESIGN MEETS REQUIREMENTS OF A.S.T.M. STANDARD C-478.
3. APPROXIMATE WEIGHT OF ONE REINFORCED CONCRETE RISER:  
24"φ - 140 lbs.  
30"φ - 165 lbs.

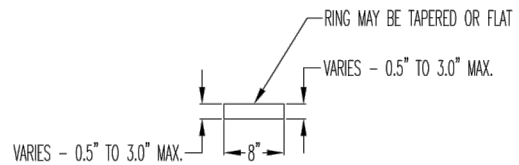
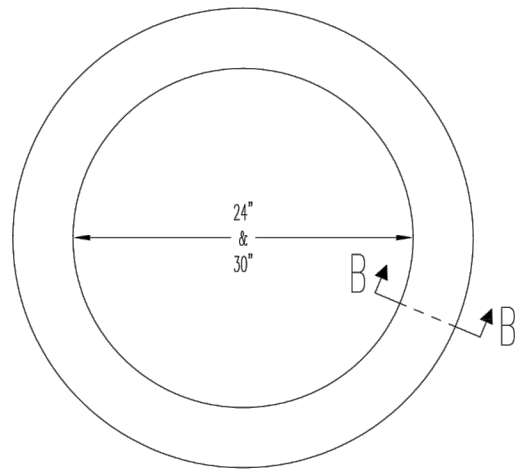

SECTION B-B

## RUBBER ADJUSTMENT RISER

(NOT TO SCALE)

### NOTES:

1. USE GNR INFRA-RISER RUBBER GRADE RINGS AS DISTRIBUTED BY EAST JORDAN IRON WORKS, INC. EAST JORDAN, MICHIGAN OR APPROVED EQUAL.
2. POLYURETHANE ADHESIVE SEALANT, CONFORMING TO ASTM-D 1850, OR EQUIVALENT, TO BE USED BETWEEN ALL CONTACT SURFACES. SEALANT TO BE APPLIED ON A DIAMETER 1" SMALLER THAN THE OUTSIDE DIAMETER OF THE RUBBER RISER.

ISSUED	2010	 <p>TOWN OF MIDDLETOWN DELAWARE</p> <p>DEPARTMENT OF PUBLIC WORKS</p>	RISER RING DETAIL
REVISED			
			STANDARD NO. S-15
SOURCE	NEW CASTLE COUNTY		

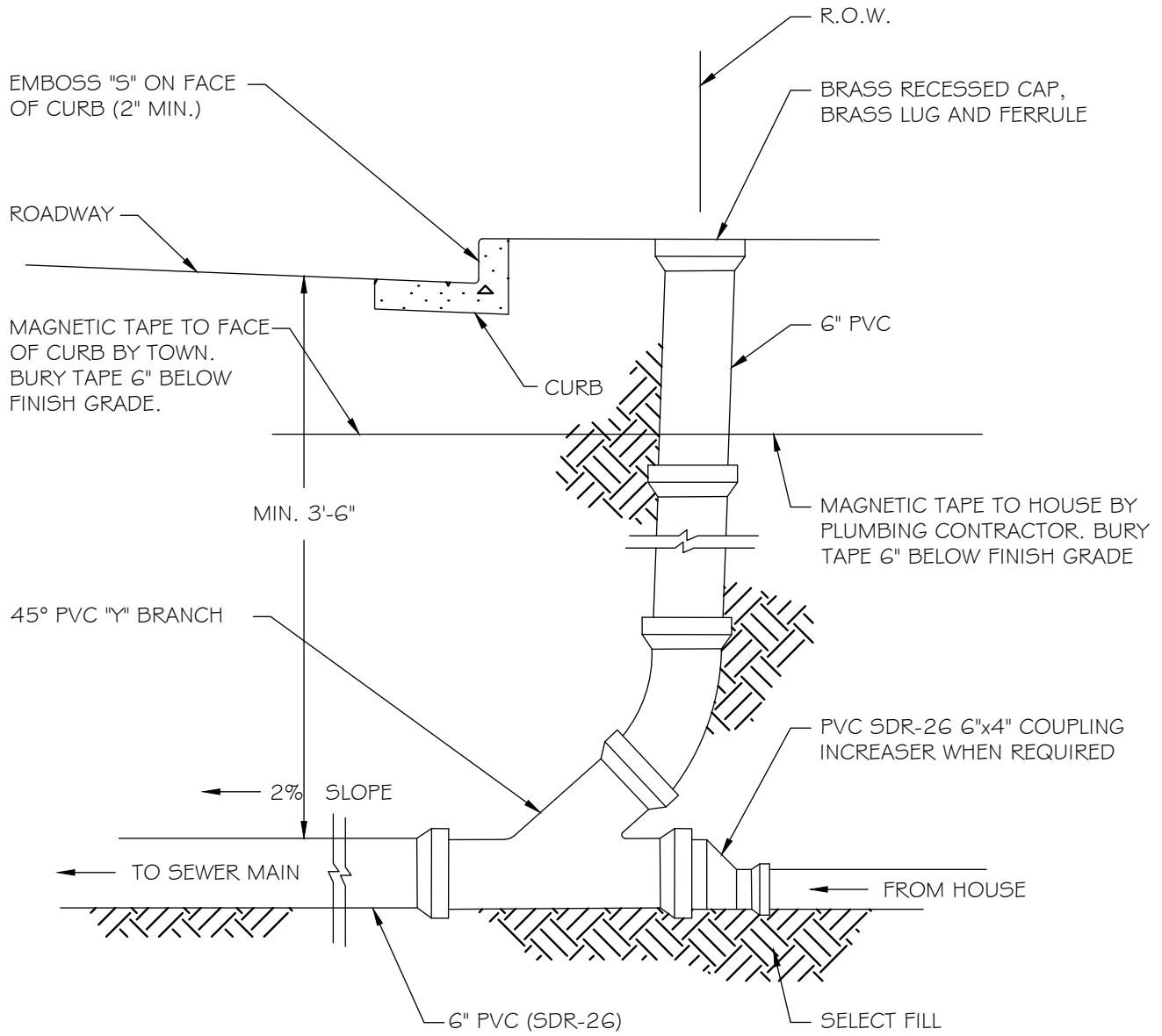

ISSUED	2010
REVISED	
SOURCE	



DEPARTMENT OF PUBLIC WORKS

## TYPICAL CLEANOUT

SANITARY SEWER DETAILS

STANDARD NO. 5-16



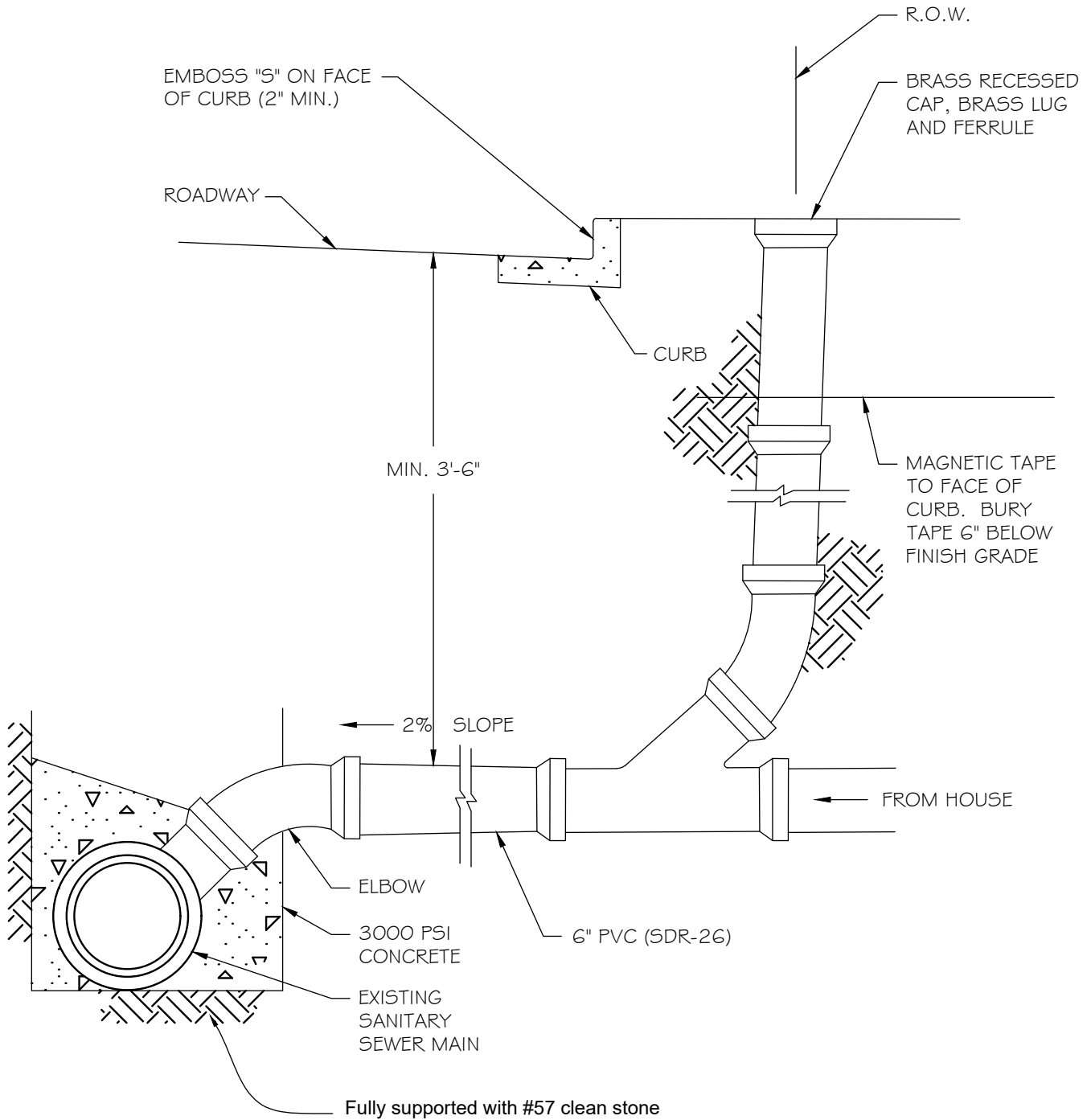

ISSUED	2010
REVISED	
SOURCE	



DEPARTMENT OF  
PUBLIC WORKS

## SEWER HOUSE CONNECTION (NEW CONSTRUCTION)

SANITARY SEWER DETAILS

STANDARD NO. S-17

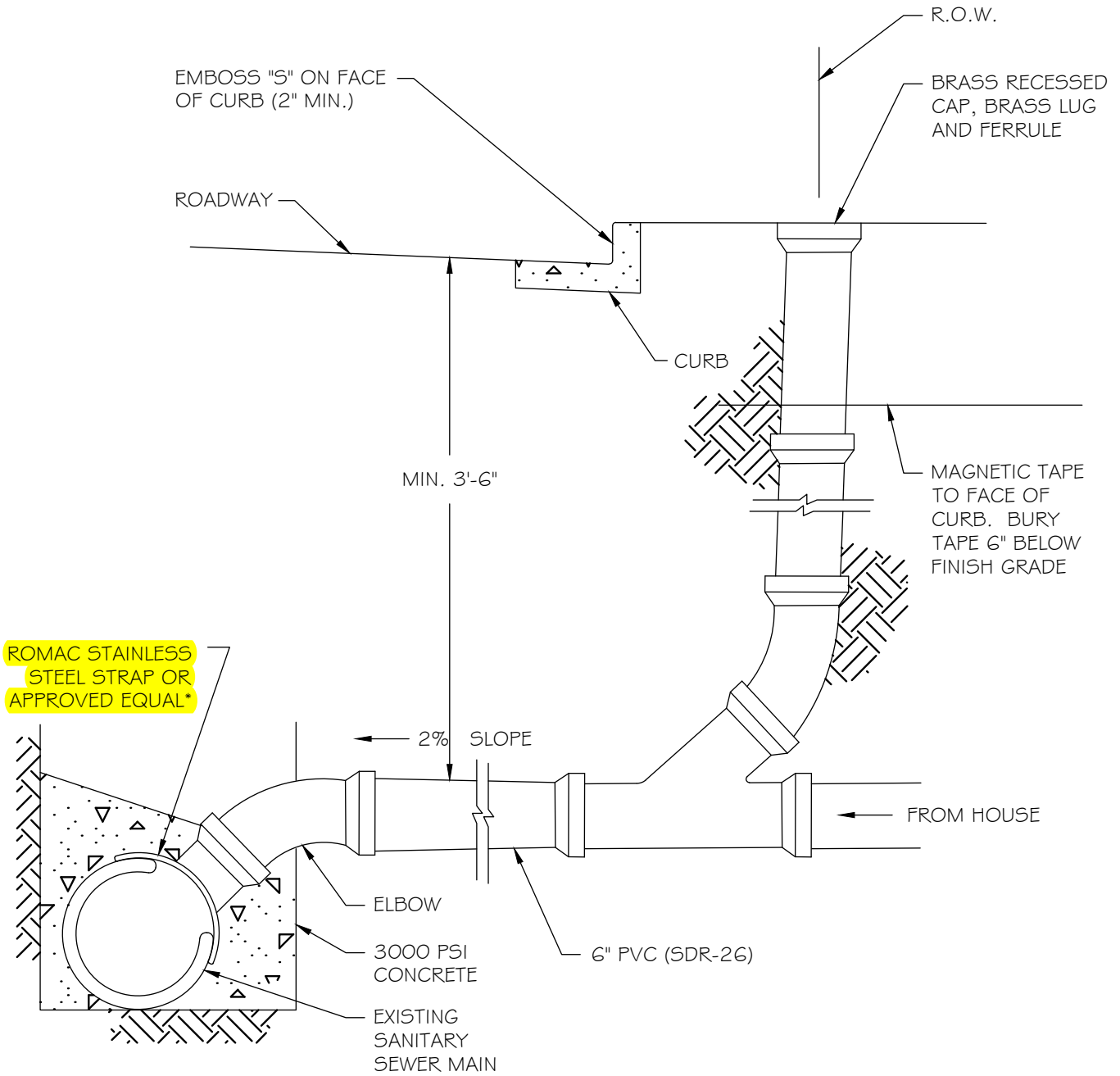

**\*NOTE: FOR CLAY PIPE, CUT PIPE AND INSERT A WYE FITTING WITH FERNCOS - SEE DETAIL S-18A.**

ISSUED	2010
REVISED	2021
SOURCE	



DEPARTMENT OF PUBLIC WORKS

## STANDARD HOUSE CONNECTION (EXISTING SEWER MAIN)

SANITARY SEWER DETAILS

STANDARD NO. S-18

EXISTING  
4" DIA. ORANGEBURG  
HOUSE LATERAL

NEW 6" x 4" FERNCO  
STRONG BACK COUPLING

NEW 6" CLEAN-OUT  
PER TOWN STANDARD S-16 OR S-17  
INSTALL AT PROPERTY LINE

PROPERTY LINE

NEW 6" DIA. PVC DR 26  
HOUSE LATERAL

NEW 6" 45° PVC DR 26 ELBOW

6" #57 STONE ENCASEMENT  
ALL AROUND

EXISTING  
8" DIA. TERRA COTTA  
SEWER LINE

NEW 8" FERNCO  
STRONG BACK COUPLING (TYPICAL BOTH SIDES)

NEW 8" x 8" x 6" PVC DR 26 WYE  
OR DOUBLE WYE

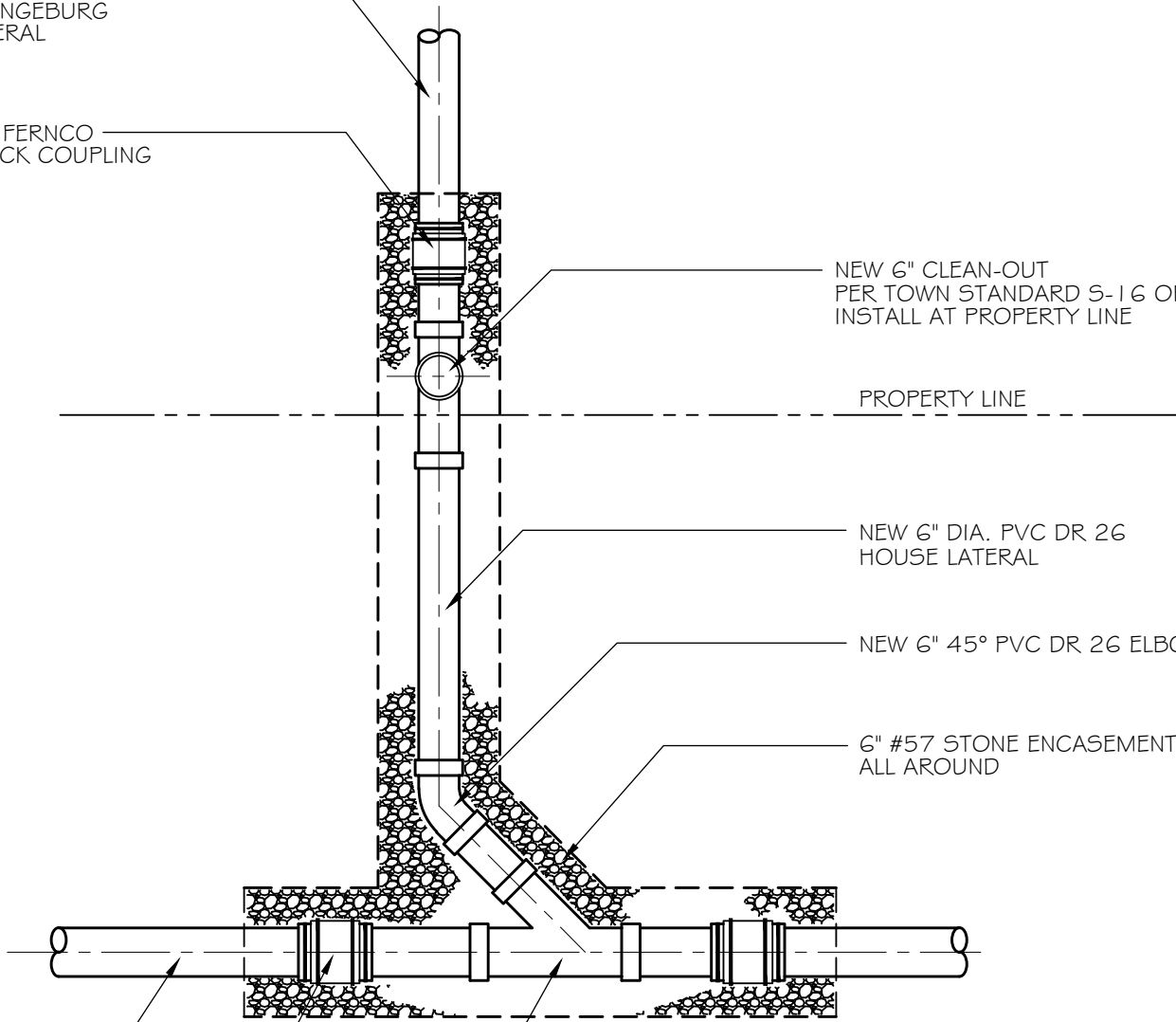

ISSUED	2021
REVISED	
SOURCE	



DEPARTMENT OF  
PUBLIC WORKS

## LATERAL CONNECTION DETAIL

SANITARY SEWER DETAILS

STANDARD NO. S-18-A

**NOTE:**

SET ON 0'-4" OF STRUCTURAL BACKFILL  
 MIN. CONCRETE AT 5000 PSI AT 28 DAYS  
 REBAR: GRADE 60 ASTM A615 SPECS

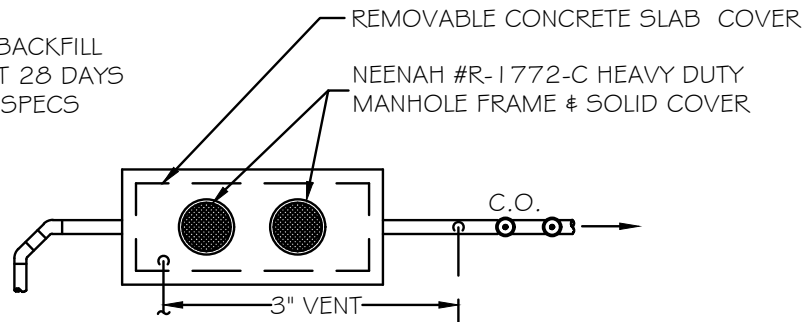

24" INSIDE DIA PRE-CAST CONCRETE  
 MANHOLE RISER SECTION

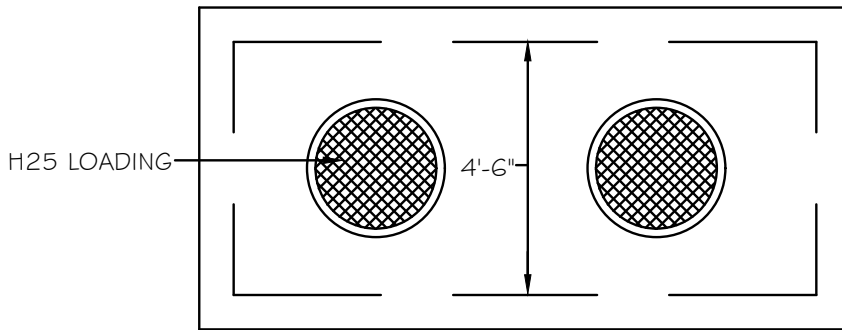
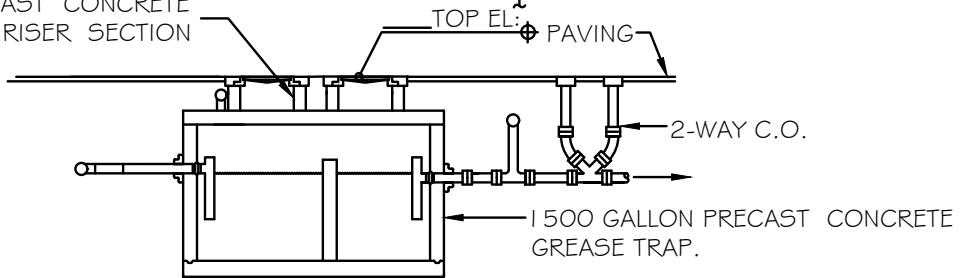

INTERIOR DIMENSIONS CHANGES ALLOWED  
 TO ACCOMPLISH SIMILAR VOLUMES.

SEAL PIPING IN  
 OPENINGS WITH  
 NEOPRENE DONUT  
 AND NON-SHRINK  
 GROUT, TYPICAL.

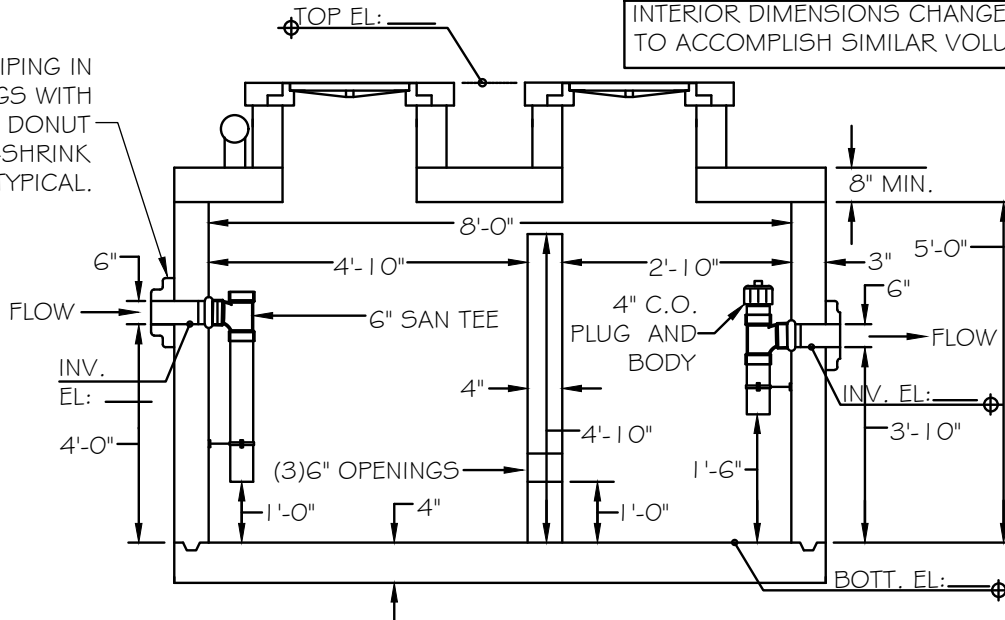

ISSUED	2021
REVISED	
SOURCE	



DEPARTMENT OF  
 PUBLIC WORKS

## GREASE TRAP

SANITARY SEWER DETAILS

STANDARD NO. 5-19

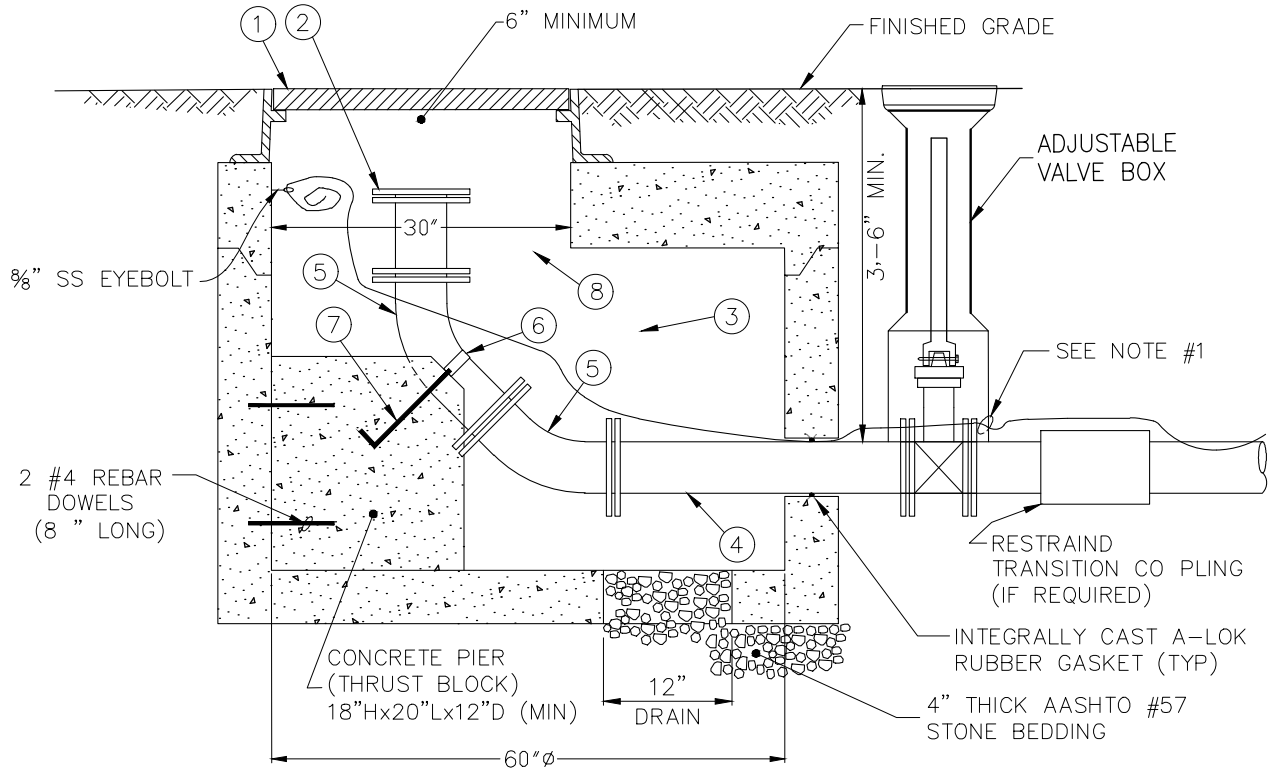

**NOTES:**

1. TRACER WIRE TO RUN ALONG ENTIRE LENGTH OF F.M. AND TO BE ACCESSIBLE TO TOP COVER. CONTRACTOR MUST PERFORM ELECTRICAL CONTINUITY TEST BEFORE ACCEPTANCE.
2. ALL NUTS & BOLTS SHALL BE STAINLESS STEEL.
3. FIRST LENGTH OF PIPE FROM CLEANOUT, THROUGH THE MANHOLE WALL SHALL BE DUCTILE IRON PIPE (DIP). TRANSITION COUPLING SHALL BE EBAA IRON MEGA-COUPLING OR APPROVED EQUIVALENT.
4. ALL DIP SHALL BE COATED WITH 2 COATS ASPHALTIC COATING.
5. KNOT TRACER WIRE AROUND EYEBOLT AND COIL ENOUGH WIRE TO EXTEND 12" ABOVE GROUND.
6. EYEBOLT SHALL BE WITHIN 3 INCHES MANHOLE COVER

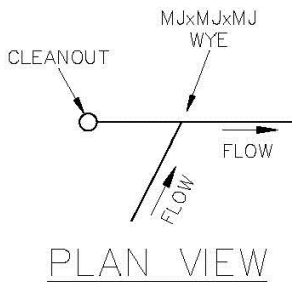

ITEM	DESCRIPTION
①	TOWN OF MIDDLETOWN STD. M.H. COVER & FRAME DETAIL (SEE S-5)
②	4" OR 6" BLIND FLANGE C.I.
③	4" OR 6" DIP (FJxPE) WITH FLANGE ADAPTER
④	4" OR 6" DIP (PExPE) WITH FLANGE ADAPTER & RETAINER GLAND
⑤	4" OR 6" DIP 45° BEND (FJxFJ)
⑥	PIPE STRAP - S.S. MIN. 1" WIDE, MIN. 1/8" THICK
⑦	J-ANCHOR - S.S., MIN. 10" LONG, 3/8" DIAMETER
⑧	GATE VALVE FLG X FLG RESILENT WEDGE

ISSUED	2021
SOURCE	NEW CASTLE COUNTY



DEPARTMENT OF PUBLIC WORKS

<h1>TERMINAL CLEANOUT FORCE MAIN</h1>
<p>SANITARY SEWER DETAILS</p>
<p>STANDARD NO. S-20</p>

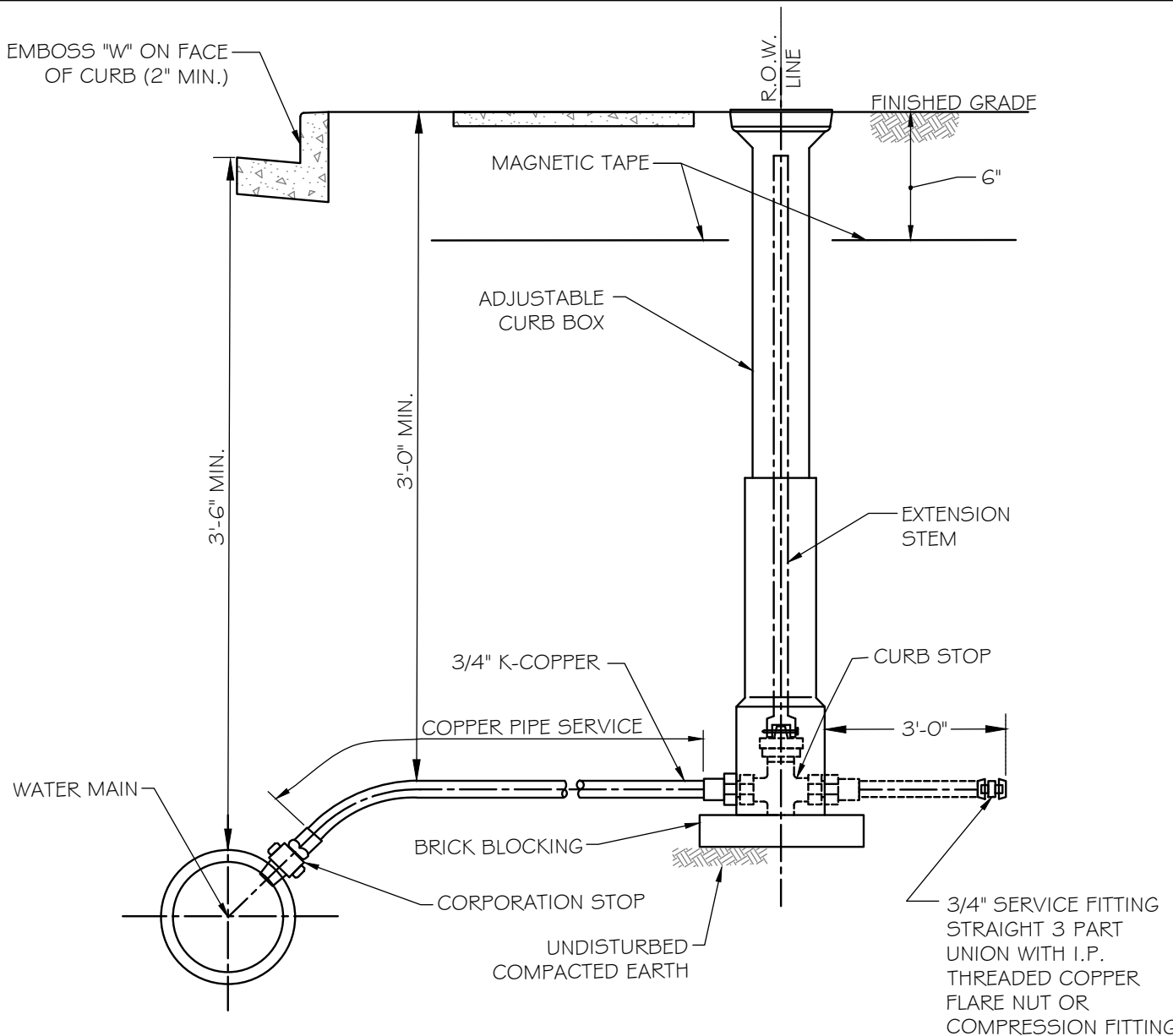

SERVICE SIZE	CORPORATION STOP	CURB STOP	CURB BOX
3/4" (MINIMUM ALLOWABLE SIZE PER DPW)	MUELLER 300 BALL CORPORATION VALVE (MODEL H-15008N)	MUELLER 300 BALL CURB VALVE (MODEL B-25209N)	MUELLER H-10385 EXTENSION RANGE, 33" TO 46"

NOTES:

- INSTALL ALL ITEMS AS SHOWN OR APPROVED EQUAL.
- NO GALVANIZED PIPING OR FITTINGS TO BE USED.
- MAGNETIC TAPE TO BE INSTALLED ABOVE PIPING, BURIED 6" BELOW GRADE.
- USE COPPER PIPE FOR SERVICES UP TO 1". USE HDPE CTS FOR SERVICES GREATER THAN 1".

ISSUED	2010		<h2 style="text-align: center;">STANDARD SERVICE CONNECTION WITH CURB BOX</h2>
REVISED	2021		
SOURCE			
			STANDARD NO. W-1

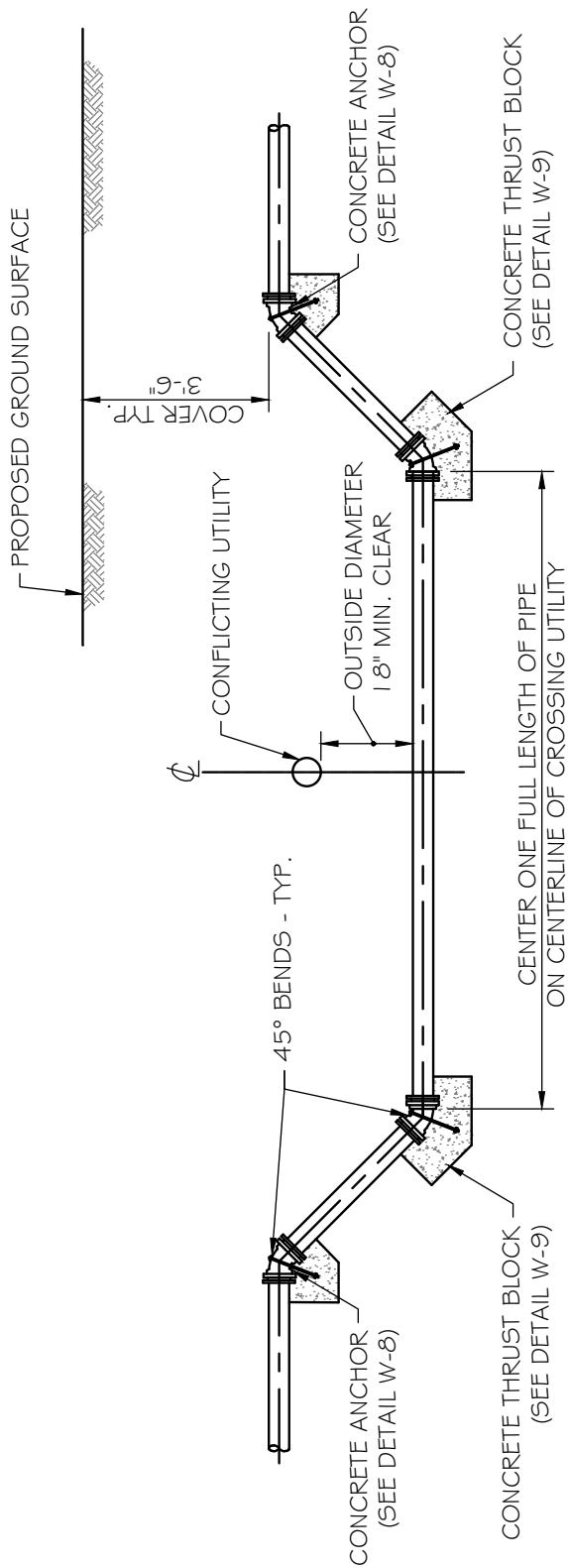

ISSUED	2010
REVISED	
SOURCE	



DEPARTMENT OF  
PUBLIC WORKS

## WATER MAIN CROSSING STORM & SANITARY SEWER

WATER DETAILS

STANDARD NO. W-2

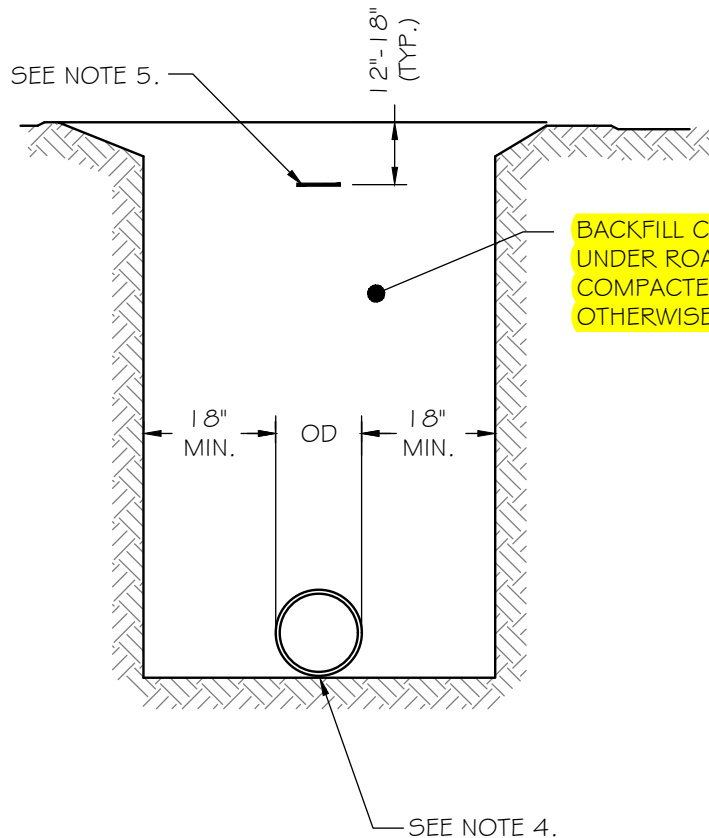

BACKFILL COMPACTED IN 8" LIFTS TO 95% MOD. PROCTOR DENSITY UNDER ROADWAY AREAS. AREAS OUTSIDE OF ROADWAYS SHALL BE COMPACTED IN 8" LIFTS TO 92% MOD. PROCTOR DENSITY UNLESS OTHERWISE NOTED ON THE PLANS.

NOTES:

1. TRENCH SHALL BE BRACED OR SHEETED IN ACCORDANCE WITH OSHA REGULATIONS.
2. PROVIDE BEARING FULL LENGTH OF BARREL.
3. DIG BELL HOLES.
4. INSTALL TRACE WIRE IN ACCORDANCE WITH THE SUPPLEMENTAL TRACE WIRE SPECIFICATIONS OF CHAPTER 46 OF THE CODE OF THE TOWN OF MIDDLETOWN.
5. INSTALL METALLIC DETECTOR TAPE PER SPECS.

ISSUED	2010	 <p>DEPARTMENT OF PUBLIC WORKS</p>	<p><b>WATER MAIN PIPE BEDDING DETAIL</b></p>
REVISED	2021		
			STANDARD NO. W-3
SOURCE			



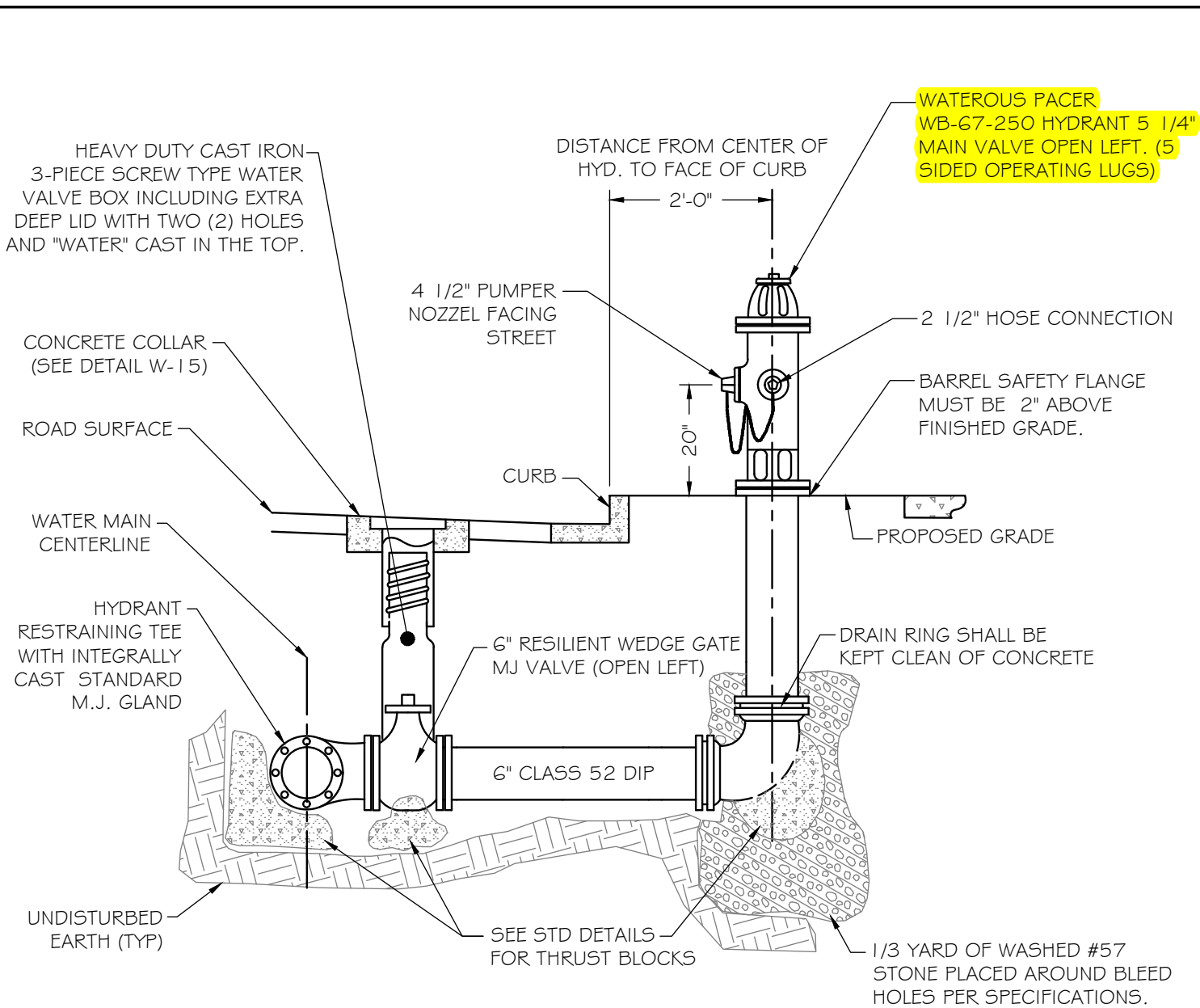

NOTES:

- 1. ALL ITEMS TO BE AS SHOWN OR APPROVED EQUAL.
- 2. HYDRANT MUST BE STRAPPED AND MECHANICALLY RESTRAINED (I.E. MEGA LUG).

ISSUED	2010		STANDARD FIRE HYDRANT INSTALLATION	
REVISED	2021			WATER DETAILS
			DEPARTMENT OF PUBLIC WORKS	STANDARD NO. W-4
SOURCE				

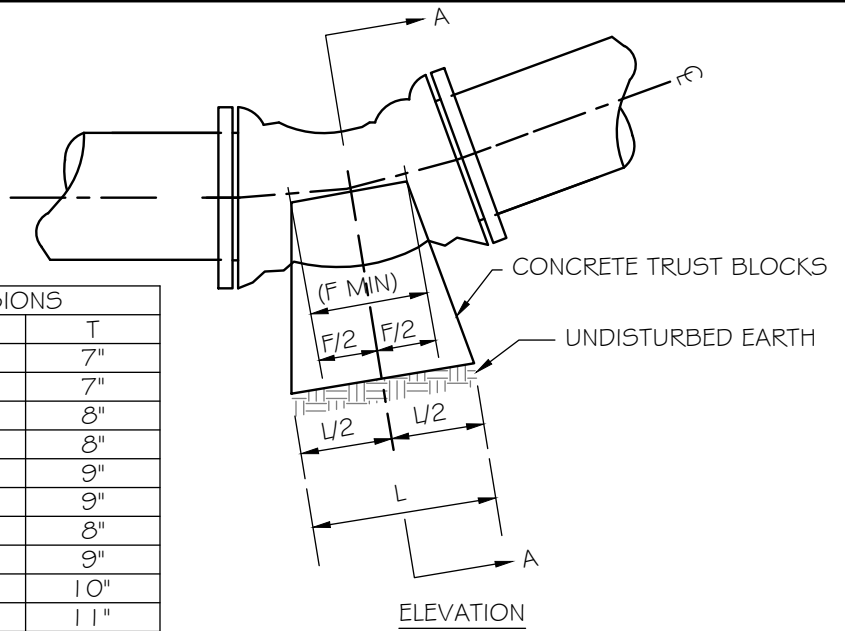

BEND TYPE	PIPE DIAMETER	THRUST BLOCK DIMENSIONS			
		L	H	F	T
1/32	6"	1'-0"	1'-2"	8"	7"
	8"	1'-4"	1'-4"	8"	7"
	10"	1'-8"	1'-6"	8"	8"
	12"	2'-0"	1'-8"	8"	8"
	14"	2'-4"	1'-10"	10"	9"
1/16	6"	1'-6"	1'-2"	8"	8"
	8"	2'-0"	1'-4"	8"	9"
	10"	3'-0"	1'-6"	8"	10"
	12"	3'-6"	1'-8"	8"	11"
	14"	4'-0"	1'-10"	10"	1'-0"
1/8	6"	1'-3"	1'-2"	8"	8"
	8"	1'-8"	1'-4"	8"	9"
	10"	2'-1"	1'-6"	8"	10"
	12"	2'-6"	1'-10"	8"	11"
	14"	2'-9"	2'-2"	10"	1'-0"
1/4	6"	1'-0"	1'-2"	8"	1'-8"
	8"	1'-4"	1'-4"	8"	1'-7"
	10"	1'-6"	2'-1"	8"	1'-7"
	12"	1'-8"	2'-6"	8"	1'-6"
	14"	2'-1"	2'-6"	10"	1'-8"
16"	2'-5"	3'-0"	11"	1'-8"	

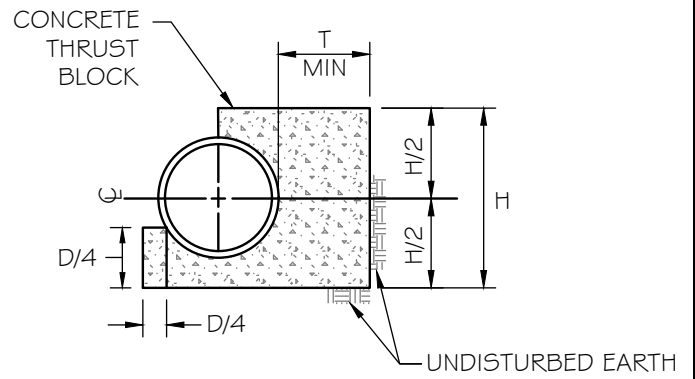

SECTION A-A

NOTES:

1. CONCRETE STRENGTH - MIN. = 3,000 PSI AT 28 DAYS.
2. STANDARD THRUST BLOCKING IS BASED ON THE FOLLOWING ASSUMPTIONS AND LIMITATIONS, IF THESE CONDITIONS ARE NOT MET, SPECIAL DESIGN IS REQUIRED:
  - A) STATIC PRESSURE IS 150 PSI OR LOWER.
  - B) DEPTH FROM FINISHED GRADE TO TOP OF PIPE ASSUMED TO EQUAL 3'-6" OR DEEPER.
  - C) ELEVATION OF GROUNDWATER TABLE ASSUMED TO BE BELOW BOTTOM OF THE BLOCK.
3. IF SOIL CONDITIONS ARE SOFT OR ORGANIC SPECIAL DESIGN IS REQUIRED (MIN. SOIL BEARING PRESSURE OF 3,000 PSF).
4. FOR LARGER PIPE DIAMETER, SEE DRAWINGS FOR SPECIAL DETAILS.
5. ALL DIMENSIONS ARE MINIMUMS EXCEPT WHERE LARGER DIMENSIONS WILL INTERFERE WITH THE PIPE JOINTS OF NOT FACILITATE BOLT REMOVAL ON MECHANICAL JOINT FITTINGS.
6. MECHANICAL JOINTS (i.e. MEGA LUGS) MAY BE USED IN LIEU OF THRUST BLOCKS FOR HORIZONTAL BENDS.

ISSUED	2010		THRUST BLOCKS FOR HORIZONTAL BENDS	
REVISED				
			DEPARTMENT OF PUBLIC WORKS	WATER DETAILS
SOURCE				STANDARD NO. W-5

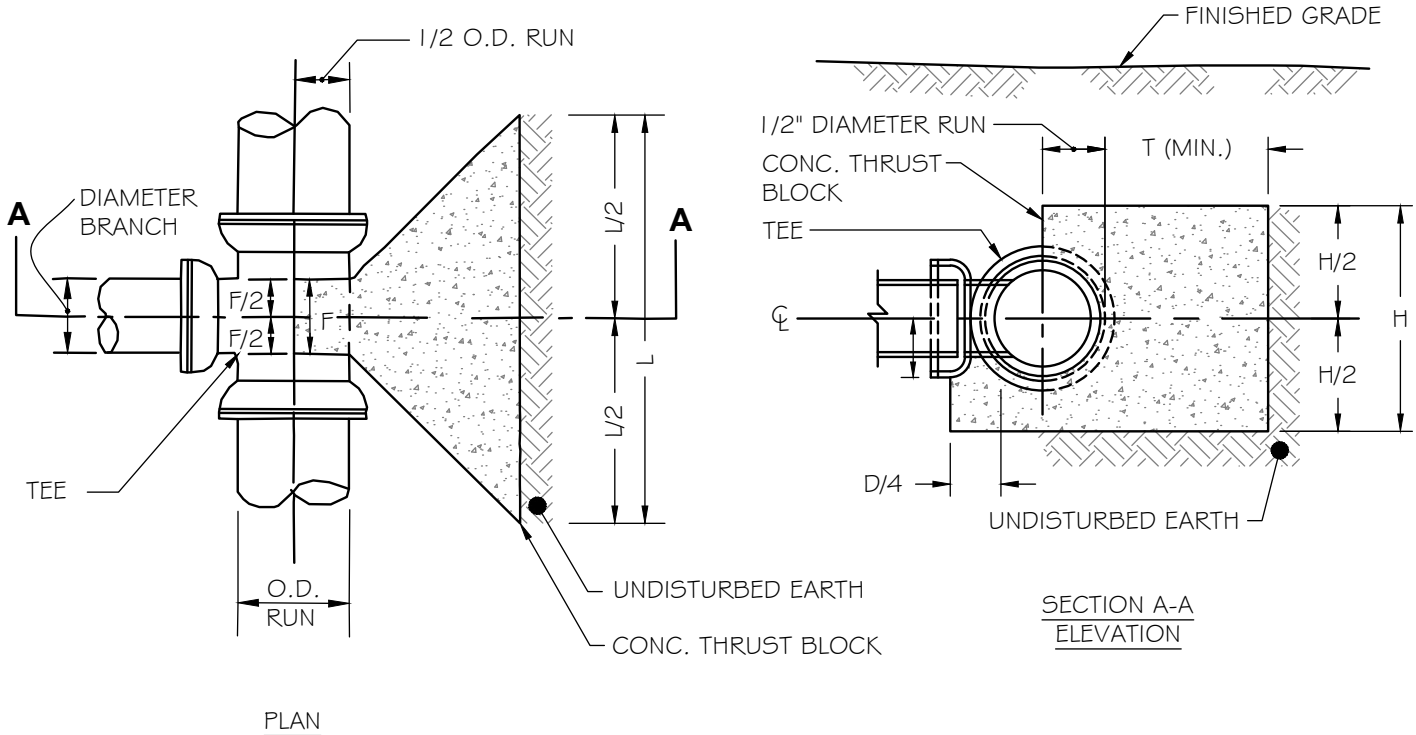

	NOMINAL DIAMETER OF BRANCH					
	6"	8"	10"	12"	14"	16"
L	1'-0"	1'-4"	2'-0"	2'-0"	2'-4"	2'-8"
H	1'-4"	1'-8"	2'-0"	2'-6"	3'-0"	3'-4"
T	8"	9"	10"	1'-0"	1'-1"	1'-2"
F	1'-0"	1'-4"	1'-4"	1'-4"	1'-6"	1'-8"

NOTES:

1. SEE BLOCKING DESIGN REQUIREMENT NOTES, STANDARD DETAIL W-5.
2. MECHANICAL JOINTS (i.e. MEGA LUGS) MAY BE USED IN LIEU OF THRUST BLOCKS FOR HORIZONTAL BENDS.

ISSUED	2010		<h2>THRUST BLOCKS FOR TEES &amp; TAPPING SLEEVES</h2>	
REVISED			WATER DETAILS	
			DEPARTMENT OF PUBLIC WORKS	STANDARD NO. W-6
SOURCE				

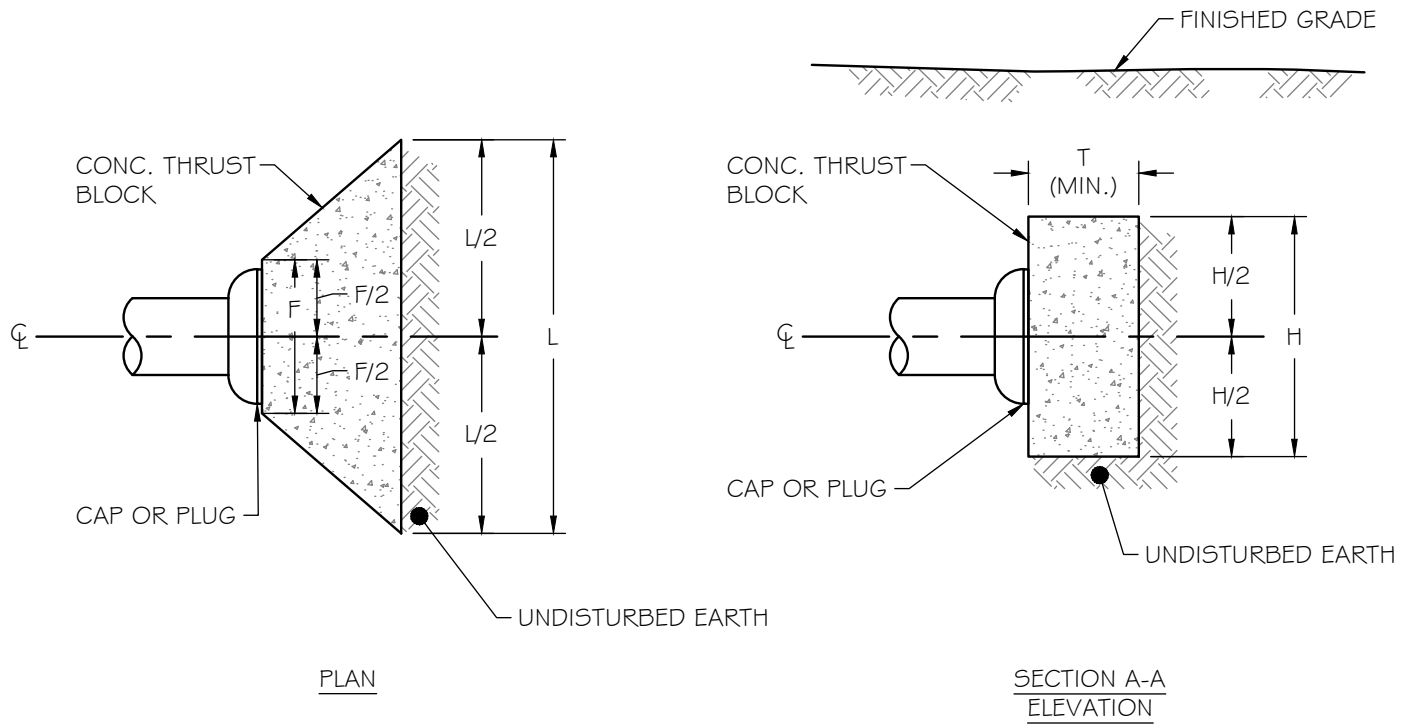

	NOMINAL DIAMETER OF BRANCH					
	6"	8"	10"	12"	14"	16"
L	1'-3"	1'-8"	2'-1"	2'-6"	3'-0"	3'-4"
H	11"	1'-2"	1'-6"	1'-9"	2'-0"	2'-4"
T	6"	8"	8"	10"	11"	1'-0"
F	8"	10"	1'-0"	1'-2"	1'-4"	1'-6"

NOTES:

1. SEE BLOCKING DESIGN REQUIREMENT NOTES, STANDARD DETAIL W-5.
2. MECHANICAL JOINTS (i.e. MEGA LUGS) MAY BE USED IN LIEU OF THRUST BLOCKS FOR PLUGS AND CAPS.

ISSUED	2010		THRUST BLOCKS FOR PLUGS & CAPS
REVISED			
			WATER DETAILS
SOURCE			DEPARTMENT OF PUBLIC WORKS

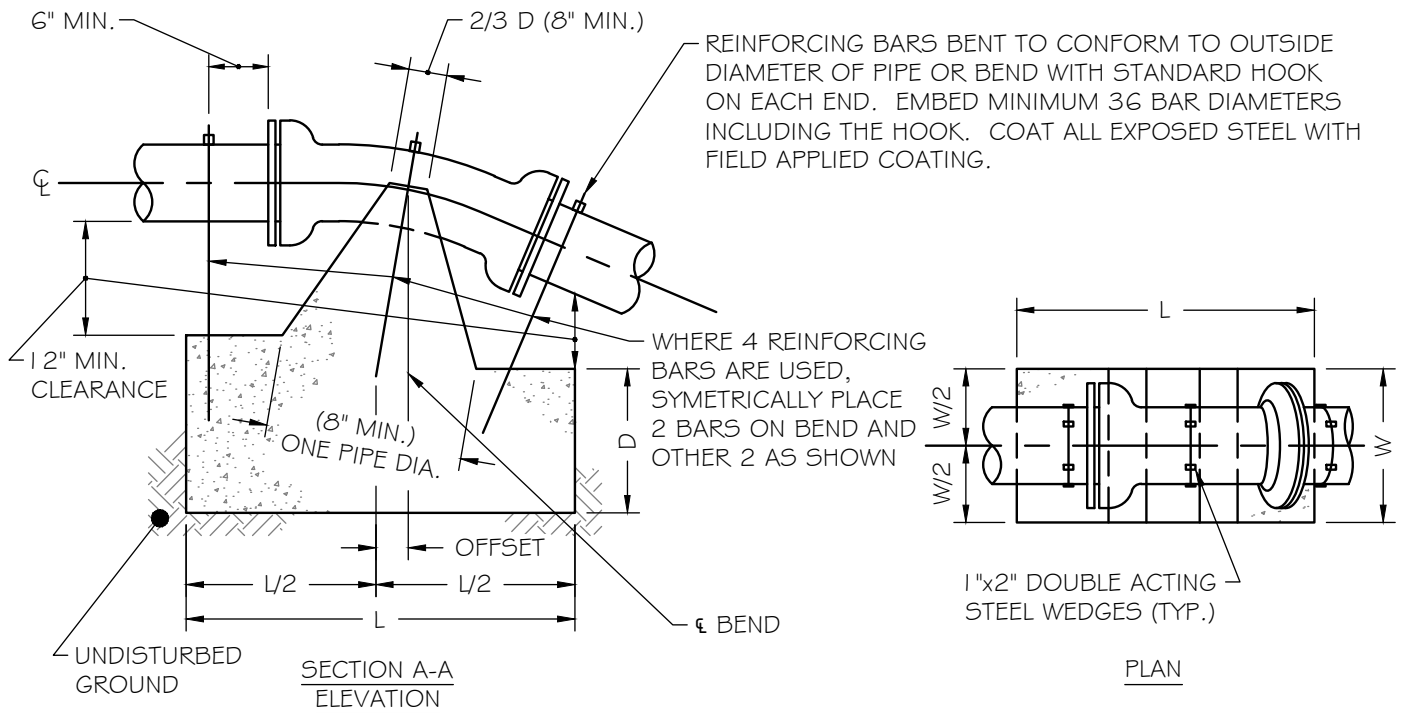

BEND		SIZE					
		6"	8"	10"	12"	14"	16"
1/32	L	2'-0"	2'-6"	2'-9"	3'-0"	3'-6"	4'-0"
	W	1'-6"	1'-6"	2'-5"	3'-0"	3'-3"	3'-6"
	D	1'-3"	1'-9"	1'-9"	2'-0"	2'-0"	2'-0"
	OFFSET	0'-6"	0'-6"	0'-6"	0'-6"	0'-6"	0'-6"
	REBAR	3 - #6	3 - #6	3 - #6	3 - #6	3 - #6	3 - #6
1/16	L	2'-6"	2'-8"	3'-10"	4'-0"	4'-8"	5'-6"
	W	2'-0"	3'-4"	3'-8"	4'-0"	4'-2"	4'-4"
	D	1'-9"	2'-3"	2'-6"	2'-6"	2'-6"	2'-6"
	OFFSET	1'-0"	1'-0"	1'-0"	1'-0"	1'-0"	1'-0"
	REBAR	3 - #6	3 - #6	3 - #6	3 - #6	3 - #6	3 - #6
1/8	L	3'-0"	4'-0"	4'-6"	4'-9"	5'-6"	6'-6"
	W	2'-6"	3'-0"	4'-0"	4'-6"	4'-10"	5'-2"
	D	2'-6"	2'-9"	3'-0"	3'-6"	3'-9"	4'-0"
	OFFSET	1'-3"	1'-6"	1'-9"	2'-0"	2'-3"	2'-6"
	REBAR	3 - #6	3 - #6	3 - #6	3 - #6	3 - #6	3 - #6

NOTES:

1. SEE BLOCKING DESIGN REQUIREMENT NOTES, STANDARD DETAIL W-5.

ISSUED	2010		<p>ANCHORAGE FOR 1/32, 1/16 &amp; 1/8 UPPER VERTICAL BENDS</p>	
REVISED				
			DEPARTMENT OF PUBLIC WORKS	WATER DETAILS
SOURCE				STANDARD NO. W-8

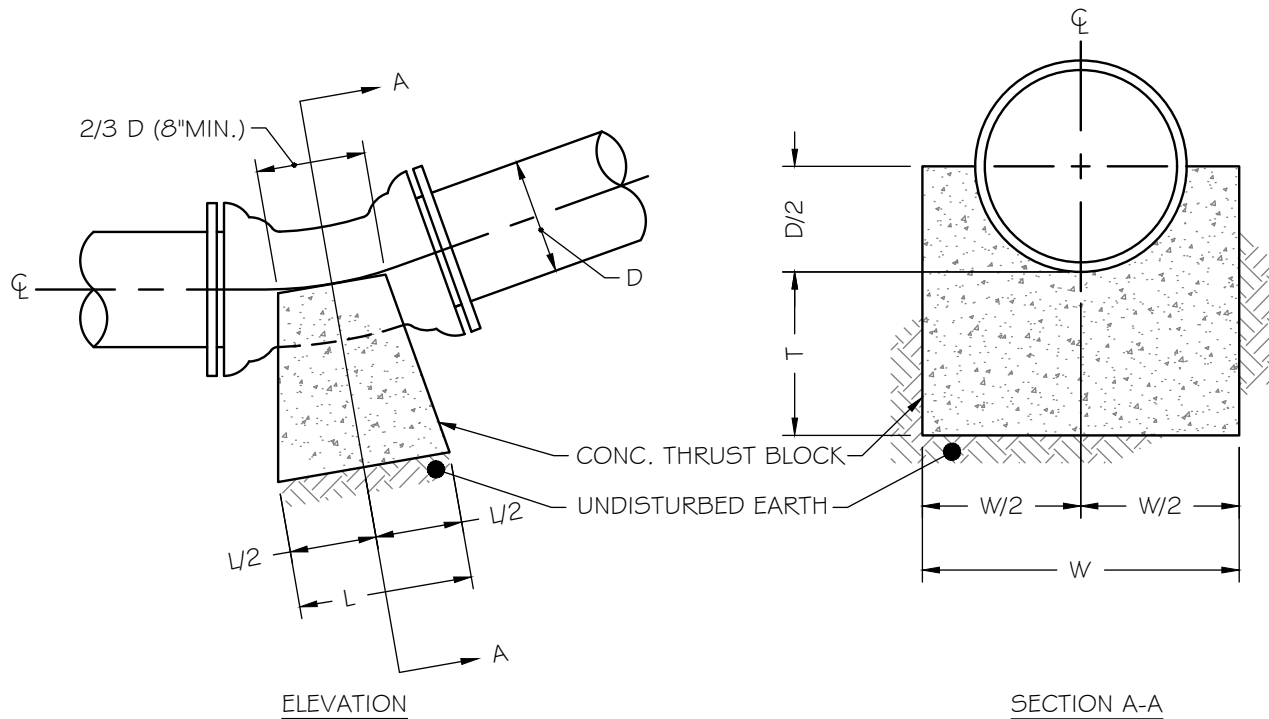

BEND		SIZE					
		6"	8"	10"	12"	14"	16"
1/32	L	0'-8"	0'-8"	0'-10"	0'-10"	1'-2"	1'-4"
	W	1'-2"	1'-4"	1'-6"	1'-8"	1'-10"	2'-0"
	T	0'-7"	0'-7"	0'-8"	0'-8"	0'-9"	0'-9"
1/16	L	0'-9"	1'-0"	1'-6"	1'-9"	2'-0"	2'-3"
	W	1'-2"	1'-4"	1'-6"	1'-8"	1'-10"	2'-0"
	T	0'-7"	0'-7"	0'-8"	0'-8"	0'-9"	0'-9"
1/8	L	1'-3"	1'-8"	2'-1"	2'-6"	3'-0"	3'-4"
	W	1'-2"	1'-4"	1'-6"	1'-10"	2'-2"	2'-6"
	T	0'-7"	0'-8"	0'-10"	0'-11"	1'-1"	1'-3"

NOTES:

1. SEE BLOCKING DESIGN REQUIREMENT NOTES, STANDARD DETAIL W-5.

ISSUED	2010		<p>THRUST BLOCKS FOR 1/32, 1/16 &amp; 1/8 LOWER VERTICAL BENDS</p>	
REVISED				
			DEPARTMENT OF PUBLIC WORKS	WATER DETAILS
SOURCE				STANDARD NO. W-9

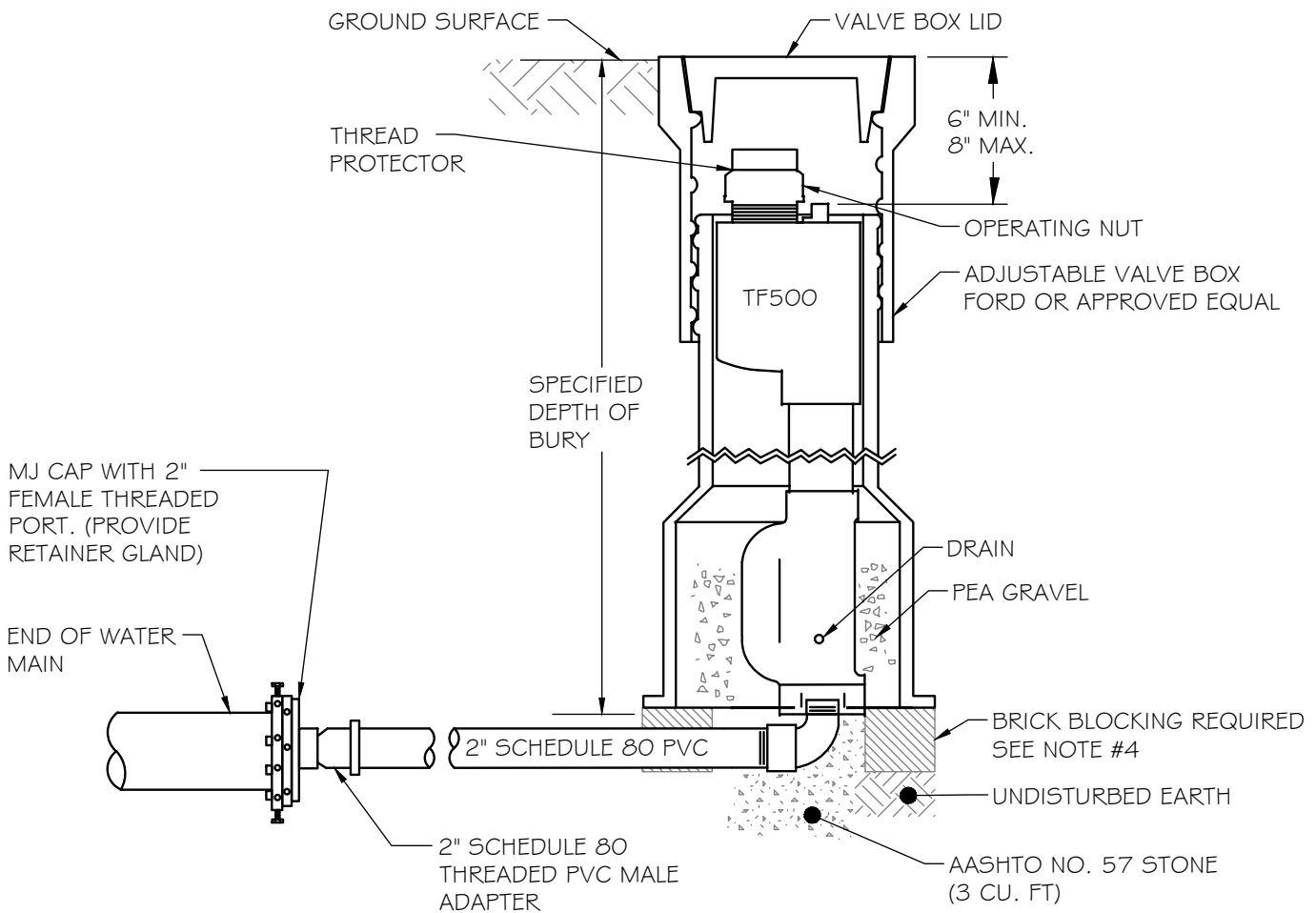

NOTES:

1. FLUSHING HYDRANT SHALL BE MODEL NO. TF-500 AS MANUFACTURED BY THE JOHN C. KUPFERLE FOUNDRY CO., ST. LOUIS, MO. OR APPROVED EQUAL.
2. HYDRANTS SHALL BE COMPRESSION TYPE CLOSING WITH THE PRESSURE AND FURNISHED WITH A 2" FIP INLET. WATER PRESSURE ALONE SHALL CLOSE THE VALVE. HYDRANTS SHALL BE OPERATED BY USE OF A PORTABLE TOP STOCK COUPLING WITH THE HYDRANT AT OR NEAR THE GROUND LINE.
3. HYDRANTS SHALL BE ARRANGED FOR DEPTH OF BURY SUITABLE FOR WATER MAIN DESIGN DEPTH OF COVER. WORKING PARTS, THREAD PROTECTOR AND OPERATING ROD SHALL BE BRASS AND REMOVABLE FROM THE HYDRANT WITHOUT THE NEED FOR EXCAVATION. BRASS THREAD PROTECTOR SHALL HAVE A 2" SQUARE NUT.
4. BRICK BLOCKING SHALL BE PROVIDED AS SHOWN AS WELL AS PARALLEL TO THE 2" SCHEDULE 80 PIPE TO FULLY SUPPORT THE VALVE BOX.

ISSUED	2010		STANDARD FLUSHING HYDRANT	
REVISED			WATER DETAILS	
			DEPARTMENT OF PUBLIC WORKS	STANDARD NO. W-10
SOURCE				

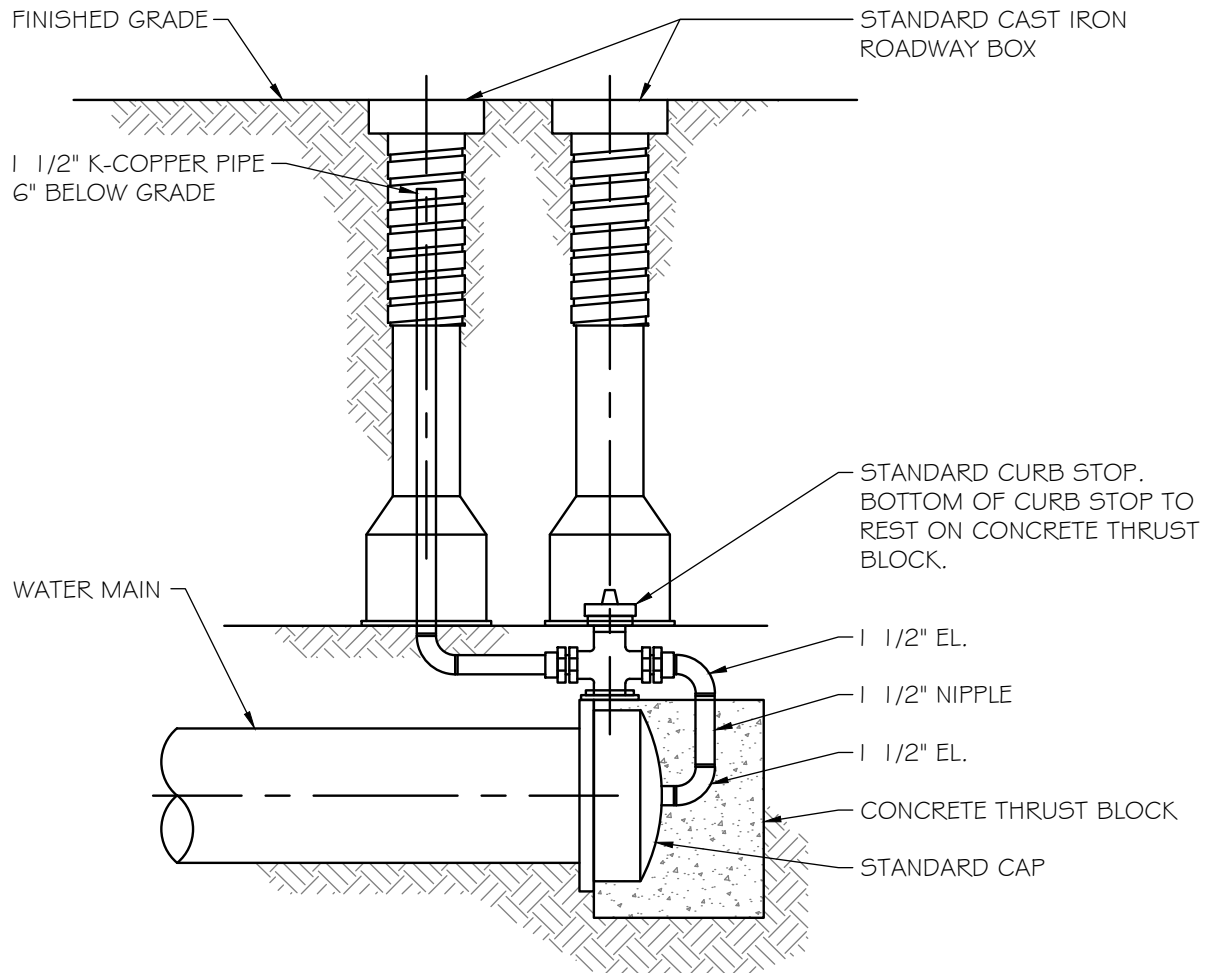

NOTES:

- 1. ALL 1-1/2" FITTINGS TO BE COPPER OR BRASS WITH FLARE OR COMPRESSION CONNECTIONS.
- 2. ALL 1-1/2" PIPING TO BE K-COPPER.

ISSUED	2010		TEMPORARY CAP & BLOW-OFF
REVISED			
			WATER DETAILS
SOURCE			DEPARTMENT OF PUBLIC WORKS



ATTENTION: WHEN INSTALLING, BACKFILL CAREFULLY TO PREVENT DISTORTING OR CRACKING PIT. DAMAGED PITS WILL NOT BE ACCEPTED!! ALTERING PIT IN ANY WAY REQUIRES PRIOR AUTHORIZATION FROM THE METER SHOP FOR INSPECTION. NO PIT EXTENSIONS ALLOWED. METER PIT SHALL BE NO MORE THAN FIVE FEET FROM THE CURB STOP.

IF A TRAFFIC DUTY LID IS REQUIRED, CALL TOWN OF MIDDLETOWN METER SHOP FOR MORE INFORMATION. (302) 378-2211

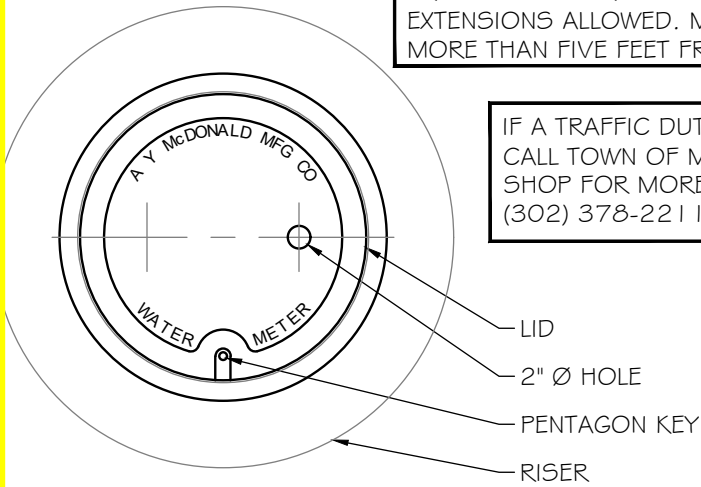

FRAME & LID COVER  
PLAN VIEW

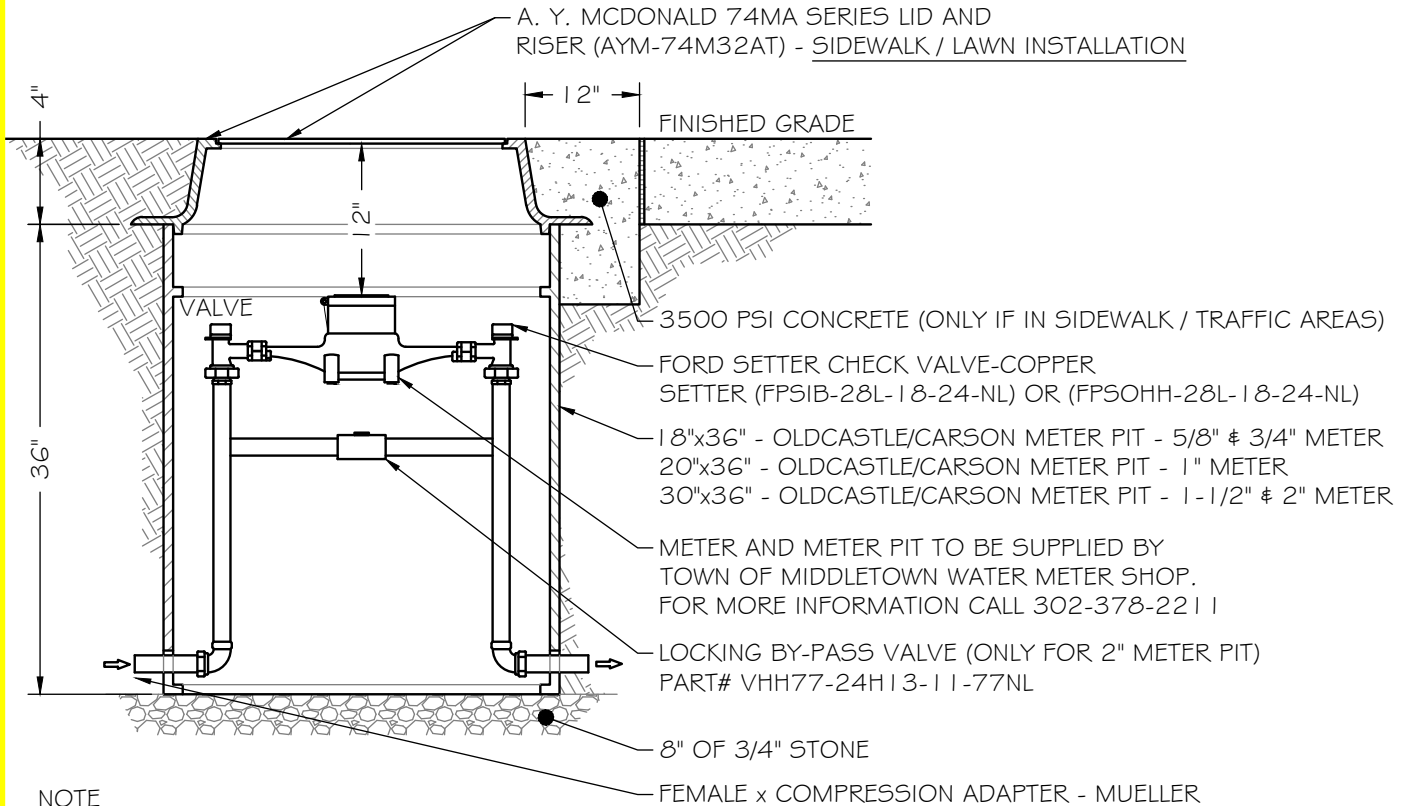
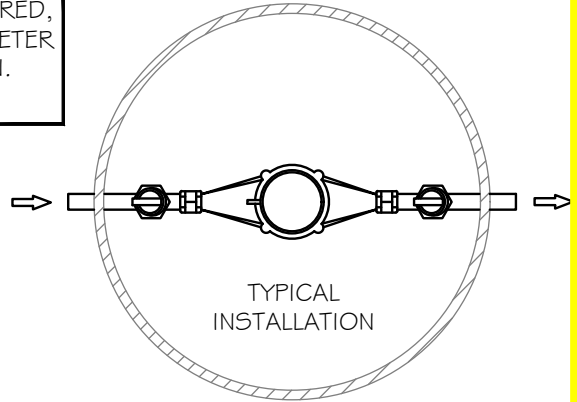

NOTE  
1. SPECIFICATIONS DUE TO CHANGE WITHOUT NOTICE. CONTACT METER SHOP FOR LATEST REVISION

FEMALE x COMPRESSION ADAPTER - MUELLER  
3/4" - H15451-NL  
1" - H15451-NL  
2" - H15451-NL

SCALE: NTS

ISSUED	2010
REVISED	2021
SOURCE	



DEPARTMENT OF  
PUBLIC WORKS

**TYPICAL METER PIT INSTALLATION  
(3/4" TO 2")**

WATER DETAILS

STANDARD NO. W-12

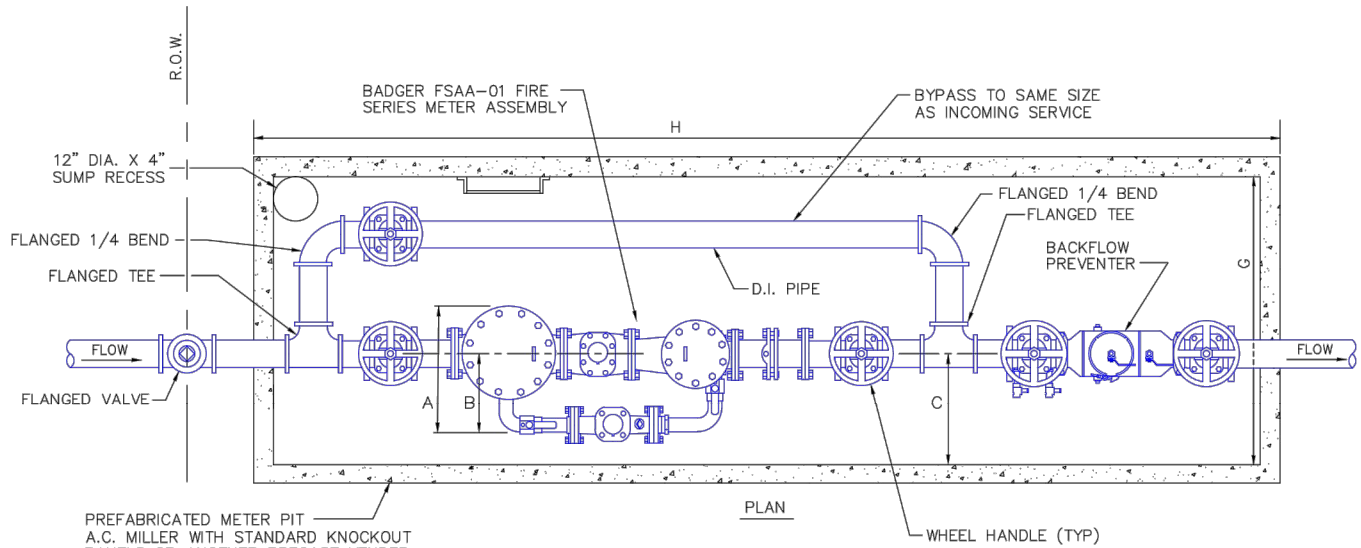

PREFABRICATED METER PIT  
A.C. MILLER WITH STANDARD KNOCKOUT  
PANELS OR ANOTHER PRECAST VENDER  
DETERMINED EQUAL BY TOWN

PLAN

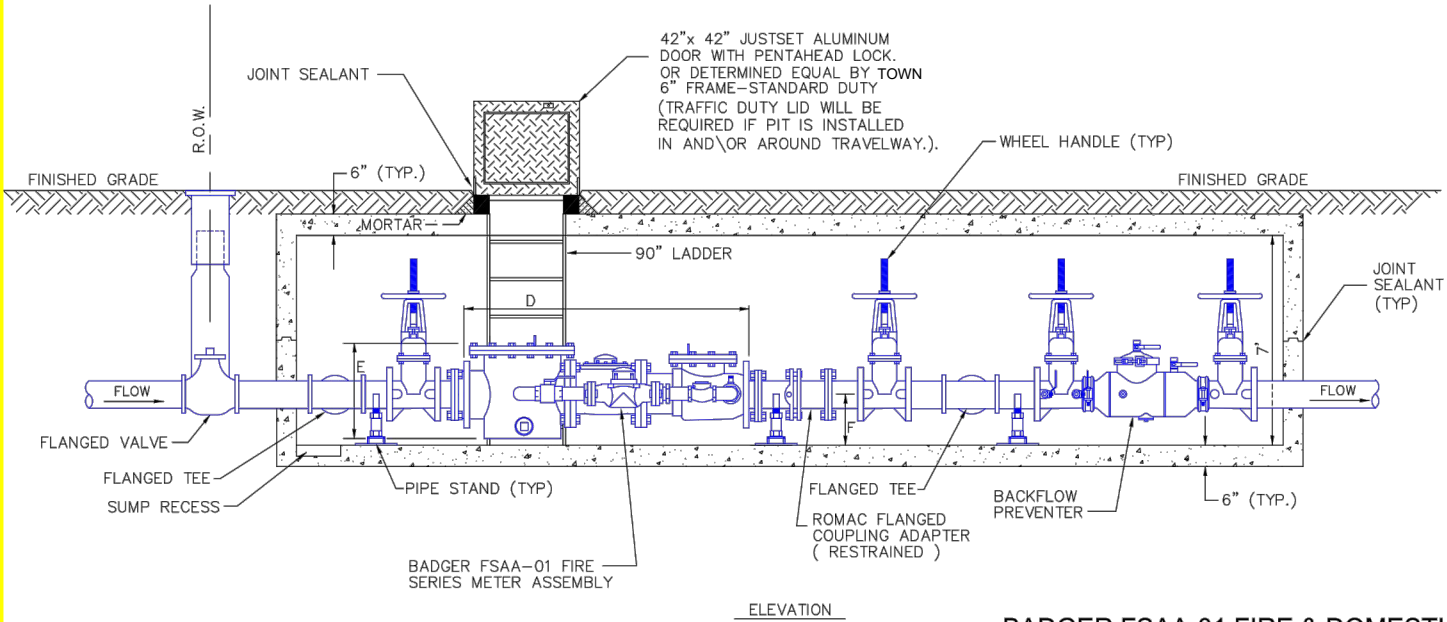

ELEVATION

**BADGER FSAA-01 FIRE & DOMESTIC  
SERVICE WATER METER ASSEMBLIES**

SIZE	4 IN.	6 IN.	8 IN.	10 IN.	12 IN.
A	22.88 IN.	29.0 IN.	30.25 IN.	34.06 IN.	34.06 IN.
B	16.13 IN.	19.50 IN.	17.75 IN.	20.31 IN.	20.31 IN.
C	28 IN. (TYP.)	28 IN. (TYP.)	28 IN. (TYP.)	28 IN. (TYP.)	28 IN. (TYP.)
D	33.0 IN.	45.0 IN.	53.0 IN.	68.0 IN.	68.0 IN.
E	20.63 IN.	22.38 IN.	25.06 IN.	25.31 IN.	33.0 IN.
F	24 IN. (TYP.)	24 IN. (TYP.)	24 IN. (TYP.)	24 IN. (TYP.)	24 IN. (TYP.)
G	7 ft.	7ft. 4in.	7ft. 4in.	7ft. 4in.	7ft. 4in.
H	13 ft.	17ft. 4in.	17ft. 4in.	20 ft.	20 ft.
NET WEIGHT	312 LBS	507 LBS	767 LBS	1073 LBS	1073 LBS
BY-PASS SIZE (NOM)	4 IN.	6 IN.	8 IN.	10 IN.	12 IN.

NOTES:

- SPECIFICATIONS DUE TO CHANGE WITHOUT NOTICE. CONTACT TOWN FOR LATEST REVISION
- METER TO BE INSTALLED BEFORE TOP HALF OF PIT IS PLACED.
- METER PIT TOP SLAB, FLOOR SLAB, AND WALLS TO BE REINFORCED.
- EXTERIOR OF VAULT TO HAVE ONE COAT OF COOPERS BITUMASTIC C4-SP APPLIED.
- PIPING MUST BE RESTRAINED WITH REACTION ANGLES ON THE EXTERIOR WALLS WITH RODDING THRU THE WALL TO THE FIRST FLANGE ON EACH END.
- INFISHIELD EXTERNAL GATOR WRAP REQUIRED OVER TOP/BOTTOM JOINT.
- 18" MINIMUM BETWEEN INSIDE WALL AND FIRST FITTING (BOTH SIDES TYPICAL)
- FINISHED GRADE SHALL SLOPE AWAY FROM ALUMINUM DOOR IN ALL DIRECTIONS TO PREVENT GROUNDWATER FROM ENTERING VAULT.
- JOINT SEALANT REQUIRED ON ALL JOINTS (CONSEAL CS102)
- BACK FLOW PREVENTER SHALL BE APOLLO VALVES MODEL DCDA-ALF-4A

NOT TO SCALE

ISSUED	2010
REVISED	2021
SOURCE	ARTESIAN WATER CO.

**COMBINED FIRE & DOMESTIC SERVICE WATER  
METER ASSEMBLY (IN PIT)**

WATER DETAILS

STANDARD NO. W-13



DEPARTMENT OF  
PUBLIC WORKS

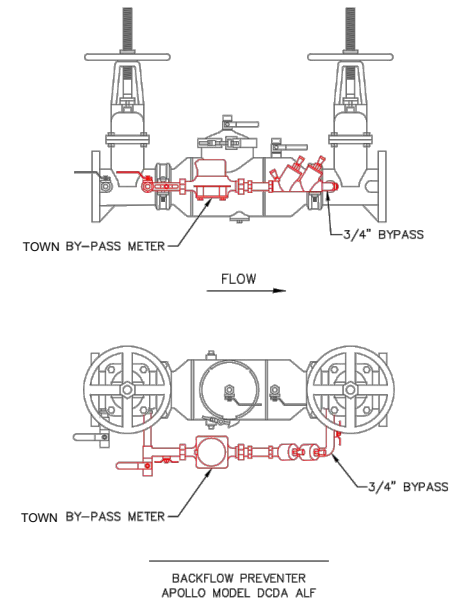
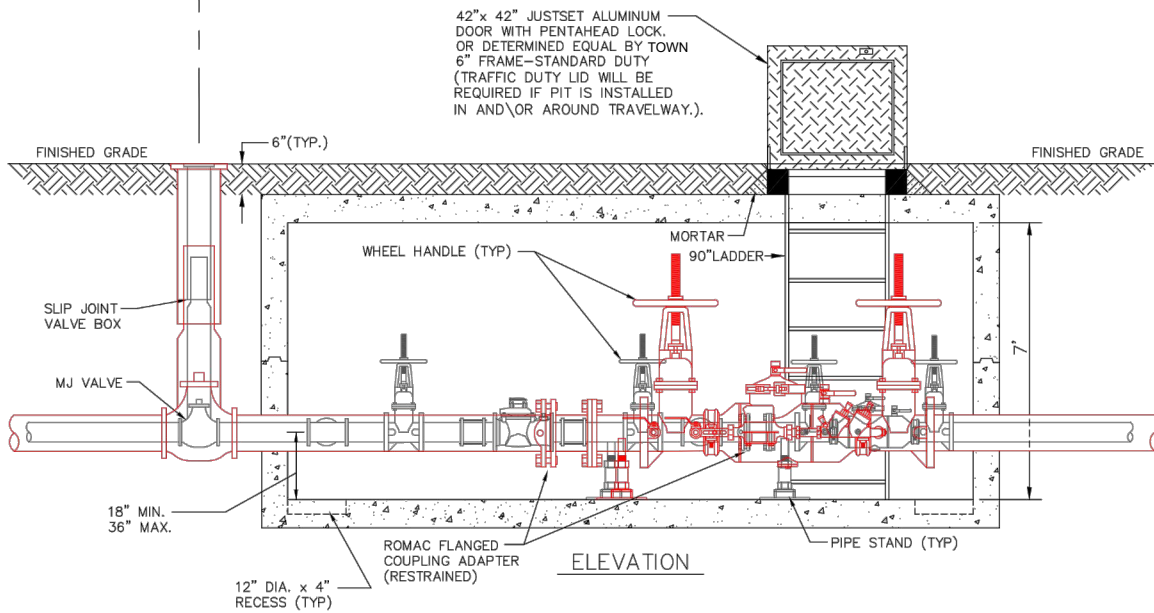
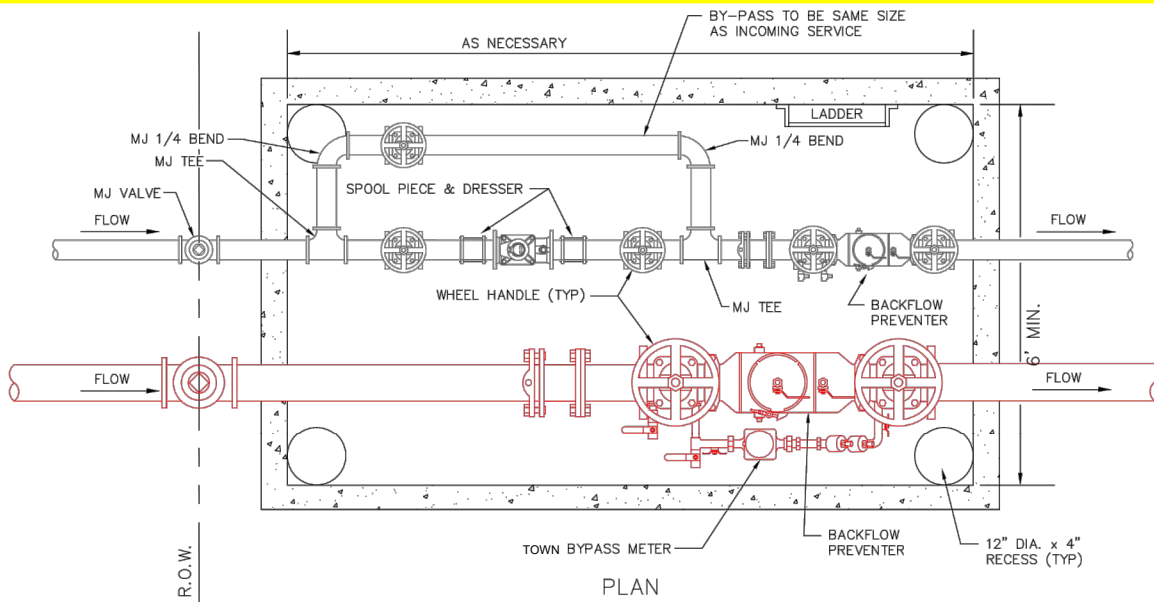

- NOTES**
1. SPECIFICATIONS DUE TO CHANGE WITHOUT NOTICE CONTACT TOWN FOR LATEST REVISION.
  2. CONTRACTOR TO INSTALL BYPASS METERS, AND FINAL INSPECTION TO BE COMPLETED BY TOWN BEFORE WATER IS TURNED ON.
  3. METER TO BE INSTALLED BEFORE TOP HALF OF PIT IS PLACED.
  4. METER PIT TOP SLAB, FLOOR SLAB, AND WALLS TO BE REINFORCED.
  5. BYPASS METER TO BE INSTALLED IN HORIZONTAL POSITION.
  6. BACKFLOW PREVENTER TO BE INSTALLED ON DOWNSTREAM SIDE OF BYPASS IN HORIZONTAL POSITION. (SUPPLIED BY CUSTOMER)
  7. ALL BACKFLOW PREVENTER BYPASSES TO BE 3/4" UNLESS OTHERWISE SPECIFIED BY TOWN
  8. BYPASS METERS SUPPLIED BY TOWN
  9. BYPASS METER TO BE ACCESSIBLE.
  10. CONTRACTOR SHALL NOT INSTALL PIPING DIRECTLY BENEATH DOOR.
  11. 18" MINIMUM BETWEEN INSIDE WALL AND FIRST FITTING (BOTH SIDES TYPICAL)
  12. FINISHED GRADE SHALL SLOPE AWAY FROM ALUMINUM DOOR IN ALL DIRECTIONS TO PREVENT GROUNDWATER FROM ENTERING VAULT.
  13. GATOR WRAPS SHALL BE INSTALLED ON ALL UNDERGROUND JOINTS.

NOT TO SCALE

**FIRE SERVICE AND DOMESTIC METER (IN PIT)**

ISSUED	2010
REVISED	2021
SOURCE	ARTESIAN WATER CO.

**SEPARATE FIRE SERVICE AND DOMESTIC METER (IN PIT)**

WATER DETAILS  
STANDARD NO. W-14



DEPARTMENT OF PUBLIC WORKS

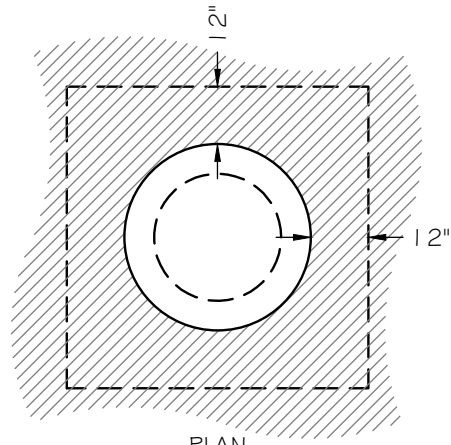

PLAN

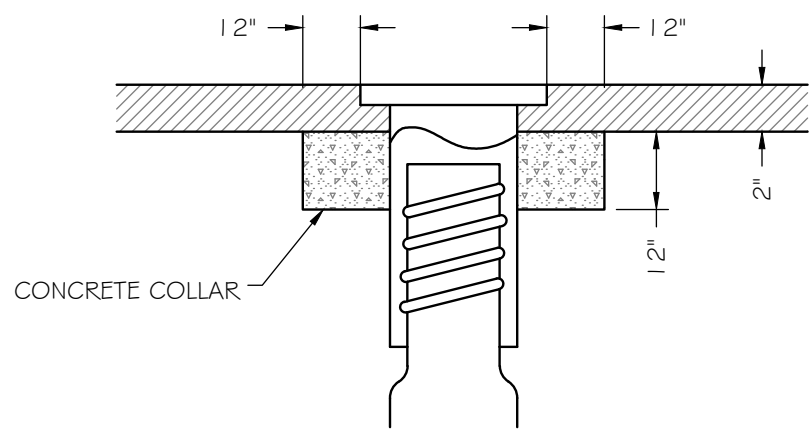

PROFILE

NOTES:

1. USE 4,000 LB MIX PORTLAND CEMENT CONCRETE.
2. FOR NEW INSTALLATION USE FORMWORK. DO NOT REMOVE FORMS FOR A MIN. OF 24 HOURS AFTER POUR. COMPACT FILL AROUND COLLAR AFTER 48 HOURS. PAVEMENT MAY BE PLACED AFTER 72 HOURS.
3. DO NOT ALLOW TRAFFIC ON CONCRETE FOR 48 HOURS UNLESS HIGH EARLY ADDITIVE IS USED.

ISSUED	2021		<h2>CONCRETE COLLAR FOR WATER MAIN VALVES</h2>
REVISED			<p>WATER DETAILS</p>
SOURCE		<p>DEPARTMENT OF PUBLIC WORKS</p>	<p>STANDARD NO. W-15</p>

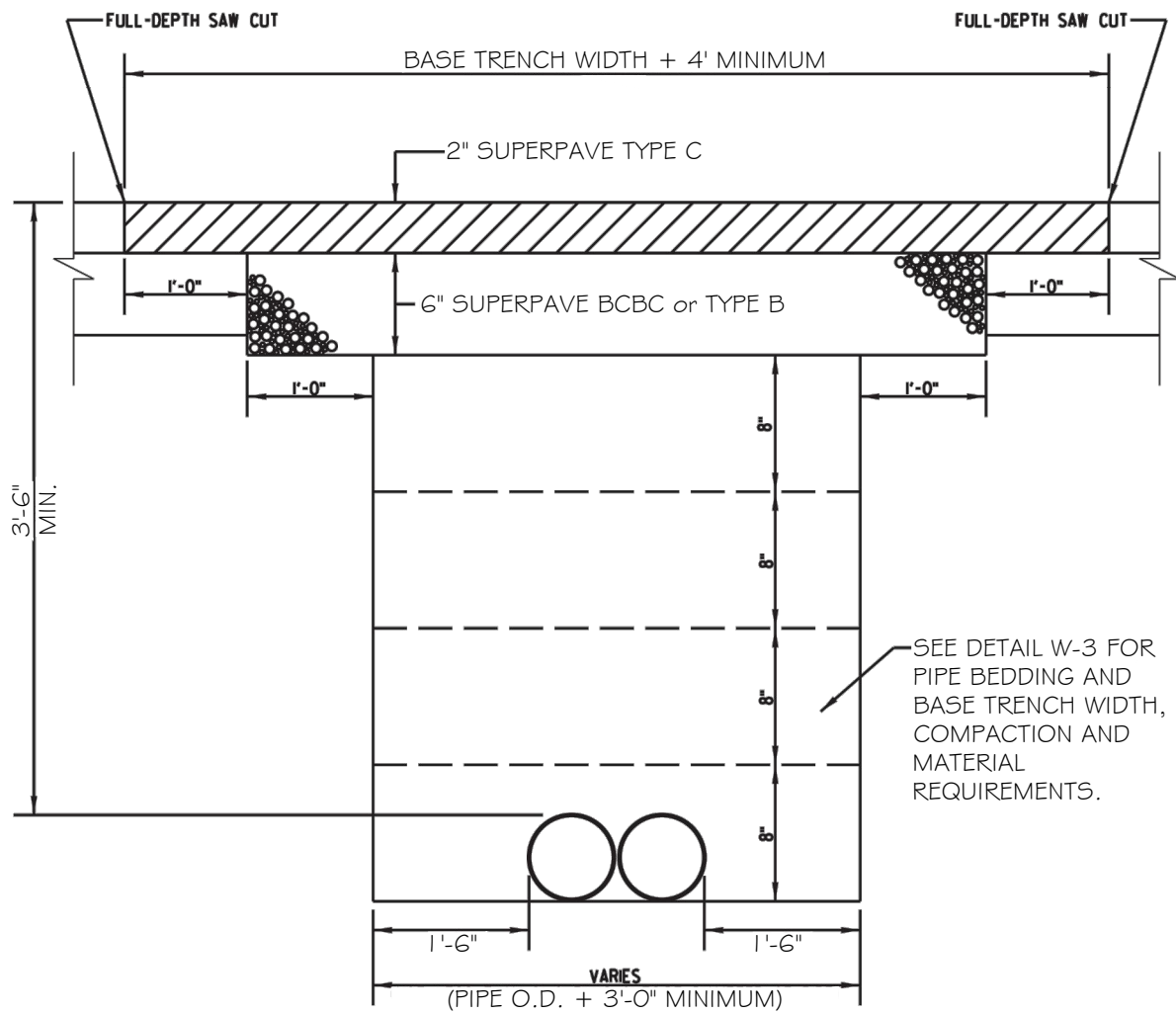

**NOTES:**

1. SURFACE ASPHALT SHALL MEET THE REQUIREMENTS OF HMA OR WMA SUPERPAVE TYPE "C" 160 GYR., PG 64-22.
2. BCBC SHALL MEET THE REQUIREMENTS OF SUPERPAVE BCBC 160 GYR., PG. 64-22 OR HMA/WMA SUPERPAVE TYPE "B" 160 GYR., PG 64-22.

ISSUED	2021	 <p>DEPARTMENT OF PUBLIC WORKS</p>	<p>PERMANENT ROAD PATCHING DETAIL FOR WATER MAINS</p>
REVISED			<p>WATER DETAILS</p>
			<p>STANDARD NO. W-16</p>
SOURCE			